

PNR

**SOLUTIONS FOR
THE PULP AND
PAPER INDUSTRY**

STOCK PREPARATION

Here we present our nozzles and washing heads that can be used in the stock preparation. For every product range, you will find some general information, a photo, a dimensional drawing, a picture of the spray and a table with the product performances. Please note that only a small part of the nozzles that PNR can manufacture and supply is on display.

To have a complete overview of our standard product range please visit our website www.pnr.eu or, if you have any special request, we invite you to write to info@pnr.it.



The main purpose of the twin-wire washer is to clean the stock pulp from contaminants, ashes and to increase the consistency. The dewatering fabrics need high pressure washing and lubrication showers.



The main purpose of a vibrating screen is to clean up the reject waste to recover fibers from the previous processing stage.

DESCRIPTION	SHOWERS	TOTAL DELIVERY (lpm)	OP. PRESSURE (bar)	WATER TYPE	PNR NOZZLES
Wire Washing	1	500	20	F / FCWW	GE
Wire Lubrication	1	500	3	CWW	GE
Vibrating Screen	1	50	3	F	K, J, HT
Tank Washing	1	---	3	F	UAC, UBA, UBC, UBT

GE

Spray Angle (x):

60° (x=Q), 75° (x=S)

Connection:

Nipple and locknut

Materials:

AISI 316Ti SS

Flow rate @ 3 bar:

From 0,90 to 39,0 lpm

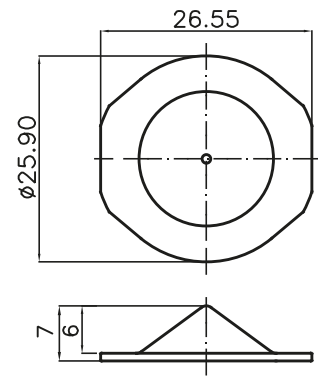

Spray Angle (x)	Code	D mm	Flow rate (lpm) at different pressure values (bar)				
			1,5	3,0	7,0	20	55
Q = 60° S = 75°	GE x 0900	0,50	0,64	0,90	1,37	2,32	3,85
	GE x 1170	0,63	1,22	1,72	2,63	4,44	7,36
	GE x 1234	0,81	1,65	2,34	3,57	6,04	10,0
	GE x 1310	1,01	2,19	3,10	4,74	8,00	13,3
	GE x 1490	1,19	3,46	4,90	7,48	12,7	21,0
	GE x 1780	1,47	5,52	7,80	11,9	20,1	33,4
	GE x 2124	2,05	8,77	12,4	18,9	32,0	53,1
	GE x 2194	1,01	13,7	19,4	29,6	50,1	83,1
	GE x 2310	1,19	21,9	31,0	47,4	80,0	133
	GE x 2390	1,47	27,6	39,0	59,6	101	167

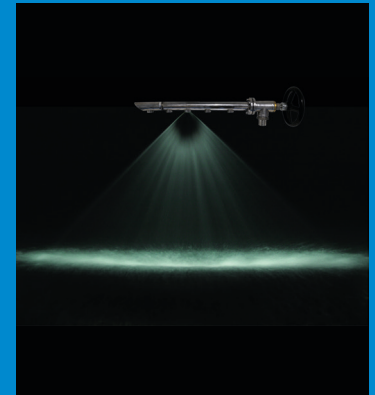

K

Spray Angle: 120°

Thread Size (y):

1/8" (y=G), 1/4" (y=H)

Materials: Brass, AISI

303 SS, AISI 316L SS

Flow rate @ 3 bar:

From 0,39 to 21,0 lpm

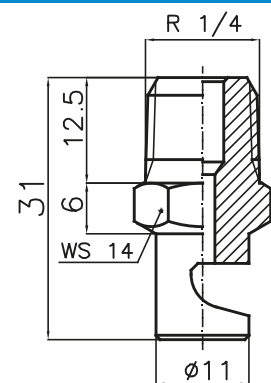

Spray Angle	Code	D mm	Flow rate (lpm) at different pressure values (bar)				
			0,5	1,0	2,0	3,0	4,0
120°	KGW 0390	0,60	0,16	0,23	0,32	0,39	0,45
	KGW 0780	0,80	0,32	0,45	0,64	0,78	0,90
	KyW 1160	1,10	0,65	0,92	1,31	1,60	1,85
	KyW 1230	1,40	0,94	1,33	1,88	2,30	2,66
	KyW 1390	1,80	1,59	2,25	3,18	3,90	4,50
	KyW 1590	2,30	2,41	3,41	4,82	5,90	6,81
	KyW 1780	2,60	3,18	4,50	6,37	7,80	9,01
	KyW 2117	3,30	4,78	6,75	9,55	11,7	13,5
	KyW 2157	3,80	6,41	9,06	12,8	15,7	18,1
	KHW 2210	4,40	8,57	12,1	17,1	21,0	24,2



J (std. capacity)

Spray Angle (x):
 60° (x=Q), 90° (x=U),
 120° (x=W)
 Thread Size (y):
 1/8" (y=A), 1/4" (y=B)
 Materials: Brass, AISI
 303 SS, AISI 316L SS
 Flow rate @ 3 bar:
 From 1,53 to 47,0 lpm

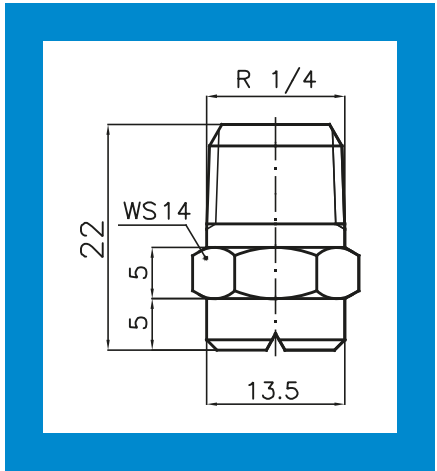

Spray Angle (x)	Code	D mm	Flow rate (lpm) at different pressure values (bar)				
			0,5	1,0	2,0	3,0	4,0
Q = 60° U = 90° W = 120°	Jyx 1153	1,25	0,62	0,88	1,25	1,53	1,77
	Jyx 1233	1,50	0,95	1,35	1,90	2,33	2,69
	Jyx 1385	1,80	1,57	2,22	3,14	3,85	4,45
	Jyx 1581	2,30	2,37	3,35	4,74	5,81	6,71
	Jyx 1780	2,70	3,18	4,50	6,37	7,80	9,01
	Jyx 1980	3,00	4,00	5,66	8,00	9,80	11,3
	Jyx 2153	3,80	6,25	8,83	12,5	15,3	17,7
	Jyx 2245	4,80	10,0	14,1	20,0	24,5	28,3
	Jyx 2310	5,40	12,7	17,9	25,3	31,0	35,8
Jyx 2470	6,20	19,2	27,1	38,4	47,0	54,3	



HT (std. capacity)

Spray Angle (x):
 60° (x=Q), 80° (x=T),
 95° (x=V)
 Connection: Quick
 Materials: Brass, AISI
 303 SS, AISI 316L SS
 Flow rate @ 3 bar:
 From 7,80 to 78,0 lpm

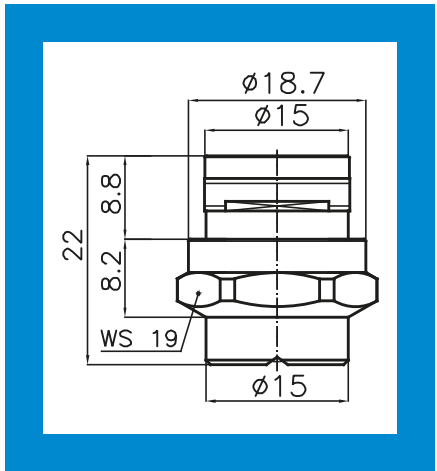

Spray Angle (x)	Code	D mm	Flow rate (lpm) at different pressure values (bar)				
			1,5	3,0	5,0	7,0	10
Q = 60° T = 80° V = 95°	HTx 1780	2,70	5,52	7,80	10,1	11,9	14,2
	HTx 1980	3,00	6,93	9,80	12,7	15,0	17,9
	HTx 2124	3,40	8,77	12,4	16,0	18,9	22,6
	HTx 2153	3,80	10,8	15,3	19,8	23,4	27,9
	HTx 2194	4,30	13,7	19,4	25,0	29,6	35,4
	HTx 2309	5,40	21,8	30,9	39,9	47,2	56,4
	HTx 2390	6,00	27,6	39,0	50,3	59,6	71,2
	HTx 2470	6,60	33,2	47,0	60,7	71,8	85,8
	HTx 2590	7,50	41,7	59,0	76,2	90,1	108
HTx 2780	8,70	55,2	78,0	101	119	142	

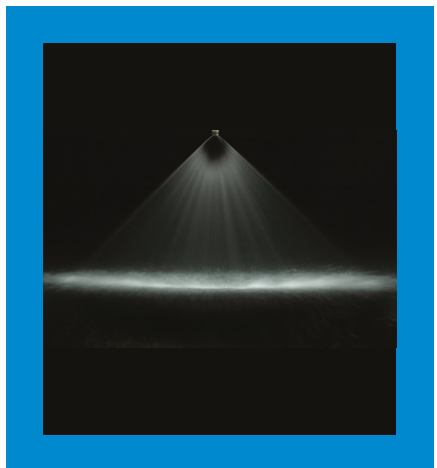

UAC

Connection:
Welded, Threaded,
Clip on
Materials:
AISI 316L SS
Wetting Radius:
From 0,50 to 3,00 m
Flow rate @ 1 bar:
From 1,2 to 49,1 m3/h

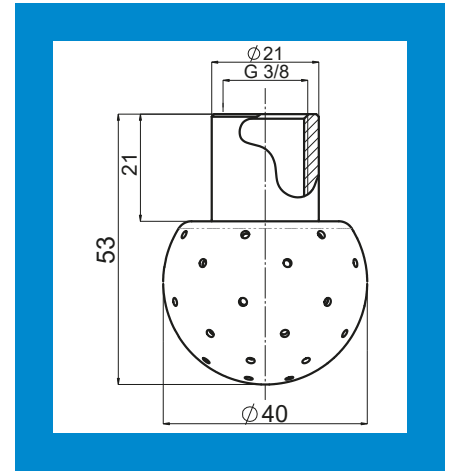

Code	Ø mm	Flow rate in m3/h at 1,0 bar	Flow rate (lpm) at different pressure values (bar)			
			0,5	1,0	2,0	3,0
UAC A012	30,0	1,20	14	20,0	28,0	35,0
UAC A014	30,0	1,40	16	23,3	33,0	40,0
UAC B021	40,0	2,10	25	35,0	50,0	61,0
UAC B038	40,0	3,80	45	63,3	90,0	110
UAC C047	50,0	4,70	55	78,3	111	136
UAC C078	50,0	7,80	92	130	184	225
UAC D102	65,0	10,2	120	170	240	295
UAC D132	65,0	13,2	155	220	310	381
UAC E175	90,0	17,5	207	292	413	505
UAC E491	90,0	49,1	580	818	1.160	1.412

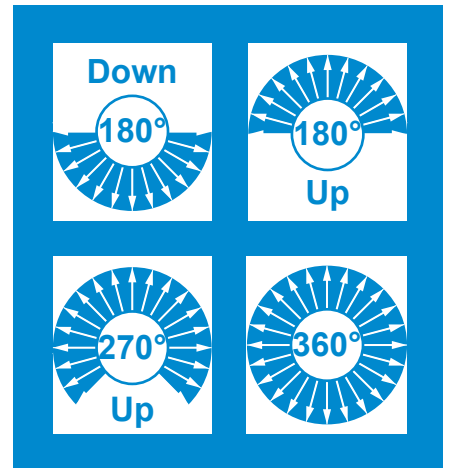

UBA

Connection:
3/4", 1-1/2"
Materials:
AISI 316L SS
Wetting Radius:
From 3,5 to 4,5 m
Flow rate @ 3 bar:
From 50,0 to 150 lpm

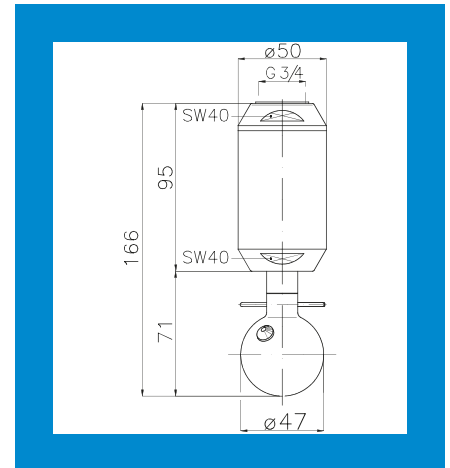

Spray Coverage	Code	Flow rate (lpm) at different pressure values (bar)				
		3,0	5,0	7,0	10	15
270° D	UBA 2500	50,0	64,5	76,4	91,3	112
360°	UBA 2500	50,0	64,5	76,4	91,3	112
360°	UBA 3150	150	194	229	274	335



UBC

Connection:
From 3/8" to 1-1/4"
Materials:
AISI 316L SS
Wetting Radius:
From 2,3 to 2,7 m
Flow rate @ 3 bar:
From 10,0 to 300 lpm

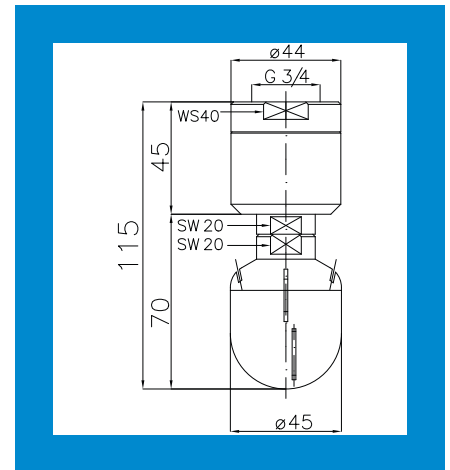

Code	Inlet inch	Flow rate (lpm) at different pressure values (bar)				
		1,0	2,0	3,0	5,0	7,0
UBC 2100	3/8"	5,77	8,16	10,0	12,9	15,3
UBC 2300	3/8"	17,3	24,5	30,0	38,7	45,8
UBC 2480	3/8"	27,7	39,2	48,0	62,0	73,3
UBC 2630	3/4"	36,4	51,4	63,0	81,3	96,2
UBC 2900	3/4"	52,0	73,5	90,0	116	137
UBC 3135	3/4"	77,9	110	135	174	206
UBC 3120	1"	69,3	98,0	120	155	183
UBC 3300	1-1/4"	173	245	300	387	458

ATEX COMPLIANCE AVAILABLE

UBT

Connection:
1" BSPP
Materials:
AISI 316L SS
Wetting Radius:
From 11 to 12 m
Flow rate @ 4 bar:
From 88 to 115 lpm

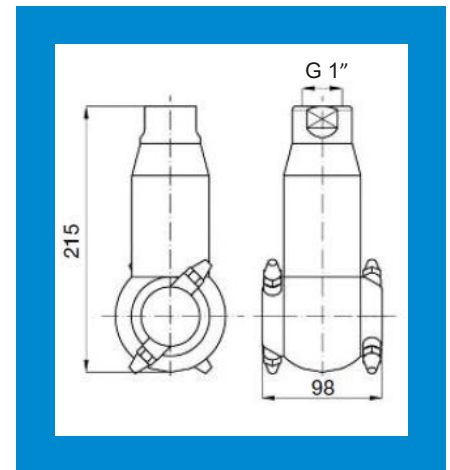

Code	Inlet inch	Nozzles Ø mm	Flow rate (lpm) at different pressure values (bar)				
			4,0	5,0	6,0	8,0	10
UBT S445	1"	4,5	88	98,4	108	124	139
UBT S460	1"	6,0	115	129	141	163	182

ATEX COMPLIANCE AVAILABLE

FORMER

This section includes the nozzles used in the former. For every product range, you will find some general information, a photo, a dimensional drawing, a picture of the spray and a table with the product performances. Please note that only a small part of the nozzles that PNR can manufacture and supply is on display.

To have a complete overview of our standard product range please visit our website www.pnr.eu or, if you have any special request, we invite you to write to info@pnr.it.

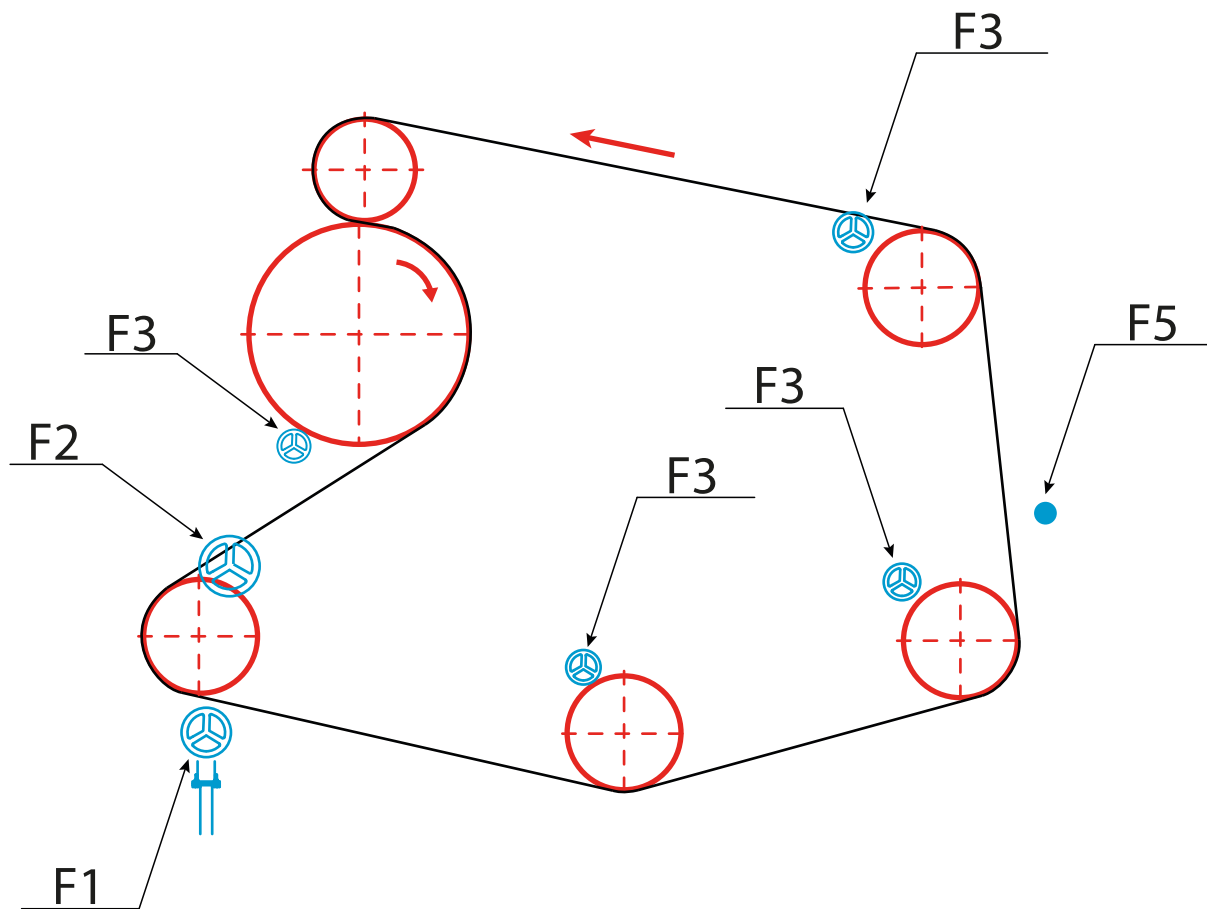

ITEM	DESCRIPTION	SHOWERS	TOTAL DELIVERY (lpm)	OP. PRESSURE (bar)	WATER TYPE	PNR NOZZLES
F1	Wire High Pressure	1	170	25	F / FCWW	GEA
F2	Flood Nip	1	2800	8	CWW	GE, K
F3	Doctor Blade	4	600	3	FCWW	GE
F5	Detergent-chemical	1	6	3	F	J, HT

GEA

Spray Angle: 0°
Connection:
 Nipple and locknut
Materials:
 AISI 316Ti SS
 AISI 316L SS with ruby insert
Flow rate @ 3 bar:
 From 0,20 to 2,22 lpm

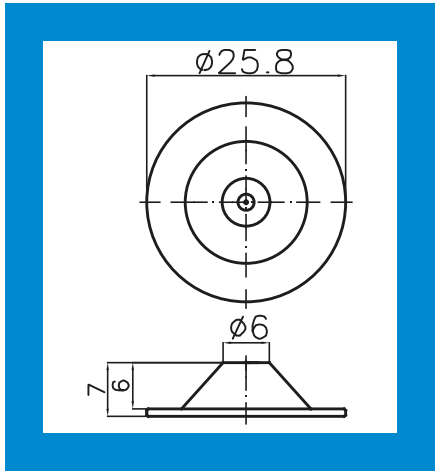

Spray Angle	Code	D mm	Flow rate (lpm) at different pressure values (bar)				
			1,5	3,0	7,0	20	55
0°	GEA 0500	0,50	0,14	0,20	0,31	0,52	0,86
	GEA 0630	0,63	0,23	0,32	0,49	0,83	1,37
	GEA 0810	0,81	0,39	0,55	0,84	1,42	2,35
	GEA 1010	1,01	0,50	0,71	1,08	1,83	3,04
	GEA 1200	1,19	0,64	0,91	1,39	2,35	3,90
	GEA 1470	1,47	0,78	1,11	1,70	2,87	4,75
	GEA 2000	2,05	1,57	2,22	3,39	5,73	9,51

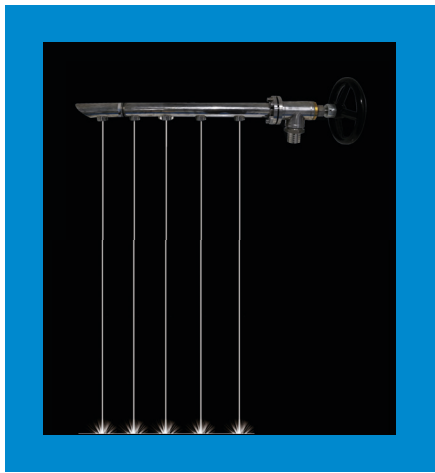

GE

Spray Angle (x):
 60° (x=Q), 75° (x=S)
Connection:
 Nipple and locknut
Materials:
 AISI 316Ti SS
Flow rate @ 3 bar:
 From 0,90 to 39,0 lpm

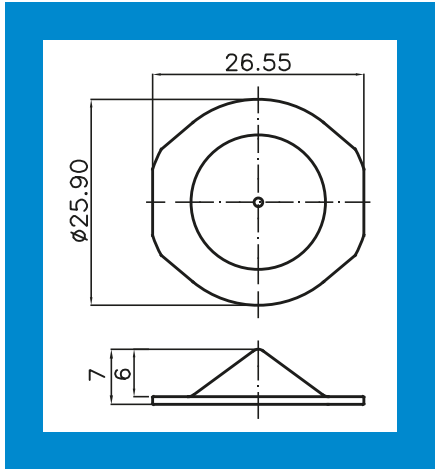

Spray Angle (x)	Code	D mm	Flow rate (lpm) at different pressure values (bar)				
			1,5	3,0	7,0	20	55
Q = 60° S = 75°	GEx 0900	0,50	0,64	0,90	1,37	2,32	3,85
	GEx 1170	0,63	1,22	1,72	2,63	4,44	7,36
	GEx 1234	0,81	1,65	2,34	3,57	6,04	10,0
	GEx 1310	1,01	2,19	3,10	4,74	8,00	13,3
	GEx 1490	1,19	3,46	4,90	7,48	12,7	21,0
	GEx 1780	1,47	5,52	7,80	11,9	20,1	33,4
	GEx 2124	2,05	8,77	12,4	18,9	32,0	53,1
	GEx 2194	1,01	13,7	19,4	29,6	50,1	83,1
	GEx 2310	1,19	21,9	31,0	47,4	80,0	133
GEx 2390	1,47	27,6	39,0	59,6	101	167	

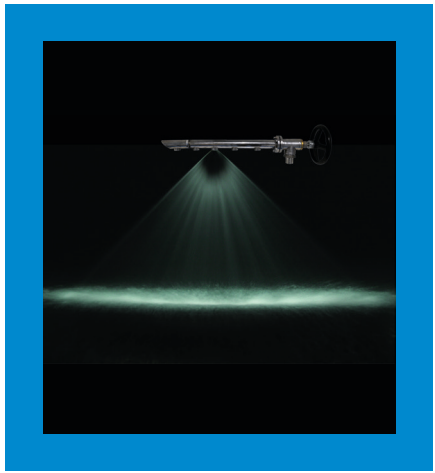

K

Spray Angle: 120°
Thread Size (y):
 1/8" (y=G), 1/4" (y=H)
Materials: Brass, AISI 303 SS, AISI 316L SS
Flow rate @ 3 bar:
 From 0,39 to 21,0 lpm

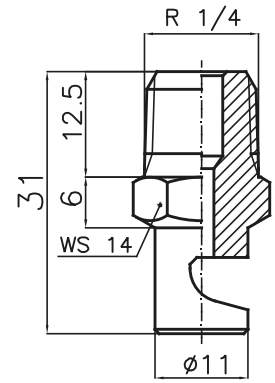

Spray Angle	Code	D mm	Flow rate (lpm) at different pressure values (bar)				
			0,5	1,0	2,0	3,0	4,0
120°	KGW 0390	0,60	0,16	0,23	0,32	0,39	0,45
	KGW 0780	0,80	0,32	0,45	0,64	0,78	0,90
	KyW 1160	1,10	0,65	0,92	1,31	1,60	1,85
	KyW 1230	1,40	0,94	1,33	1,88	2,30	2,66
	KyW 1390	1,80	1,59	2,25	3,18	3,90	4,50
	KyW 1590	2,30	2,41	3,41	4,82	5,90	6,81
	KyW 1780	2,60	3,18	4,50	6,37	7,80	9,01
	KyW 2117	3,30	4,78	6,75	9,55	11,7	13,5
	KyW 2157	3,80	6,41	9,06	12,8	15,7	18,1
	KHW 2210	4,40	8,57	12,1	17,1	21,0	24,2



J (low capacity)

Spray Angle (x):
 65° (x=R), 80° (x=T),
 95° (x=V), 110° (x=J)
Thread Size (y):
 1/8" (y=A), 1/4" (y=B)
Materials: Brass, AISI 303 SS, AISI 316L SS
Flow rate @ 3 bar:
 From 0,06 to 1,60 lpm

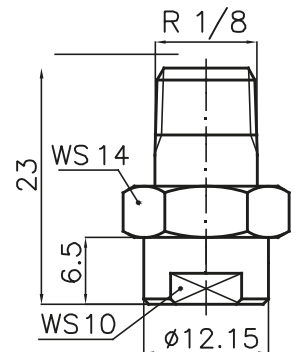

Spray Angle (x)	Code	D mm	Flow rate (lpm) at different pressure values (bar)				
			0,7	1,0	1,5	2,0	3,0
R = 65° T = 80° V = 95° J = 110°	Jyx 0060	0,28	0,029	0,035	0,04	0,05	0,06
	Jyx 0100	0,34	0,048	0,06	0,07	0,08	0,10
	Jyx 0150	0,40	0,07	0,09	0,11	0,12	0,15
	Jyx 0200	0,46	0,096	0,12	0,14	0,16	0,20
	Jyx 0260	0,53	0,10	0,15	0,18	0,21	0,26
	Jyx 0390	0,66	0,19	0,23	0,28	0,32	0,39
	Jyx 0590	0,79	0,28	0,34	0,42	0,48	0,59
	Jyx 0780	0,91	0,38	0,45	0,55	0,64	0,78
	Jyx 1120	1,10	0,58	0,69	0,85	0,98	1,20
	Jyx 1160	1,30	0,77	0,92	1,13	1,31	1,60



HT (low capacity)

Spray Angle (x):

60° (x=Q), 80° (x=T),

95° (x=V), 110° (x=J)

Connection: Quick

Materials: Brass, AISI

303 SS, AISI 316L SS

Flow rate @ 3 bar:

From 0,26 to 5,80 lpm

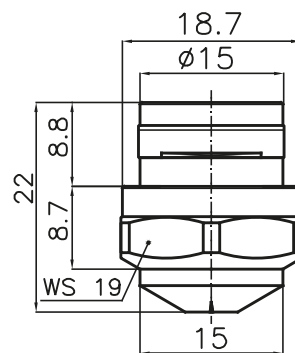

Spray Angle (x)	Code	D mm	Flow rate (lpm) at different pressure values (bar)				
			1,5	3,0	5,0	7,0	10
Q = 60° T = 80° V = 95° J = 110°	HTx 0260	0,50	0,18	0,26	0,34	0,40	0,47
	HTx 0390	0,63	0,28	0,39	0,50	0,60	0,71
	HTx 0590	0,81	0,42	0,59	0,76	0,90	1,08
	HTx 1160	1,01	1,13	1,60	2,07	2,44	2,92
	HTx 1190	1,19	1,34	1,90	2,45	2,90	3,47
	HTx 1230	1,47	1,63	2,30	2,97	3,51	4,20
	HTx 1310	1,70	2,19	3,10	4,00	4,74	5,66
	HTx 1385	1,85	2,72	3,85	4,97	5,88	7,03
	HTx 1490	2,10	3,46	4,90	6,33	7,48	8,95
HTx 1581	2,30	4,10	5,80	7,49	8,86	10,6	



PRESS SECTION

In this section, you will find the nozzles for use in the press section. For every range, you will find some general information, a photo, a dimensional drawing, a picture of the spray and a table with the product performances. Please note that only a small part of the nozzles that PNR can manufacture and supply is on display.

To have a complete overview of our standard product range please visit our website www.pnr.eu or, if you have any special request, we invite you to write to info@pnr.it.

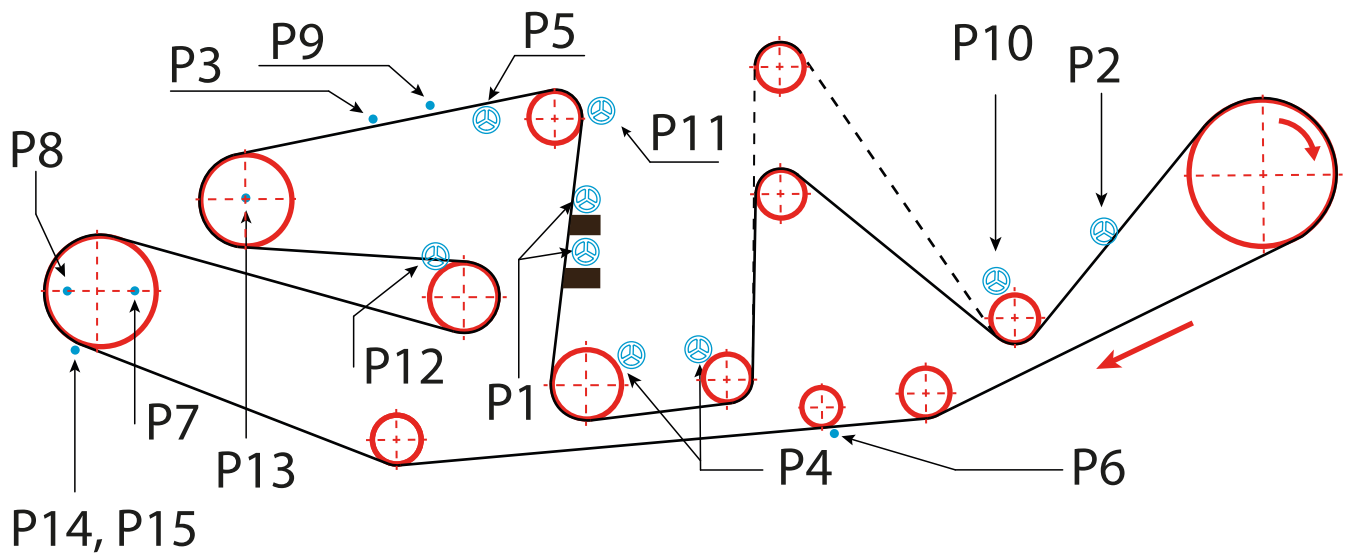

ITEM	DESCRIPTION	SHOWERS	TOTAL DELIVERY (lpm)	OP. PRESSURE (bar)	WATER TYPE	PNR NOZZLES
P1	Uhle Box Lubrication	2	520	3	CWW	GE
P2	Felt Feeding	1	500	3	FCWW	GE
P3	Felt Cleaning H.P.	1	3	25	F / FCWW	GMA, GDA, FBA
P4	Doctor Lubrication	2	2	260	CWW	GE
P5	Felt High Volume	1	1000	3	FCWW	GE, K
P6	Tail Cutter	1	2	10	SF / F	GMA
P7	Suction Roll Cleaning	1	600	3	F	K
P8	Suction Roll Lubrication	1	60	1,5	F	K
P9	Detergent Chemical	1	120	3	F	J, HT
P10	Felt Washing	1	130	3	FCWW	GE
P11	Fan Shaped on Fel	1	225	8	FCWW / CWW	GE
P12	Cleaning Roll	1	90	3	CWW	GE
P13	Roll Cooling	1	90	1,5	F	---
P14	Trimmers	1	4	10	F	GMA
P15	Trimmers	1	4	10	F	GMA

GE

Spray Angle (x):

60° (x=Q), 75° (x=S)

Connection:

Nipple and locknut

Materials:

AISI 316Ti SS

Flow rate @ 3 bar:

From 0,90 to 39,0 lpm

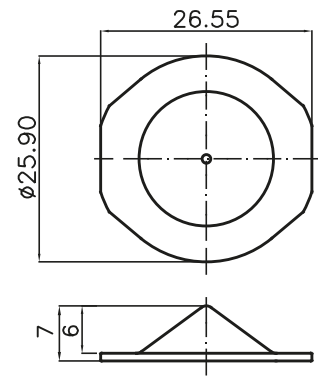

Spray Angle (x)	Code	D mm	Flow rate (lpm) at different pressure values (bar)				
			1,5	3,0	7,0	20	55
Q = 60° S = 75°	GEx 0900	0,50	0,64	0,90	1,37	2,32	3,85
	GEx 1170	0,63	1,22	1,72	2,63	4,44	7,36
	GEx 1234	0,81	1,65	2,34	3,57	6,04	10,0
	GEx 1310	1,01	2,19	3,10	4,74	8,00	13,3
	GEx 1490	1,19	3,46	4,90	7,48	12,7	21,0
	GEx 1780	1,47	5,52	7,80	11,9	20,1	33,4
	GEx 2124	2,05	8,77	12,4	18,9	32,0	53,1
	GEx 2194	1,01	13,7	19,4	29,6	50,1	83,1
	GEx 2310	1,19	21,9	31,0	47,4	80,0	133
GEx 2390	1,47	27,6	39,0	59,6	101	167	

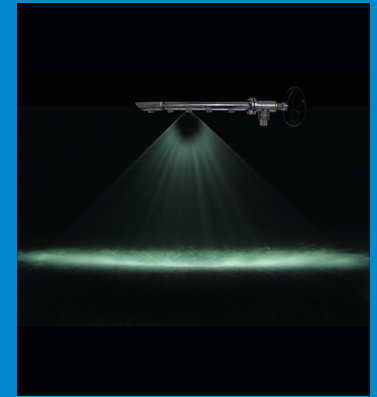

GMA

Spray Angle: 0°

Thread Size: 3/8"

Materials:

AISI 303 SS, AISI 316L

SS, ruby insert

Orifice diameter:

From 0,25 to 1,91 mm

Flow rate @ 30 bar:

From 0,36 to 3,64 lpm

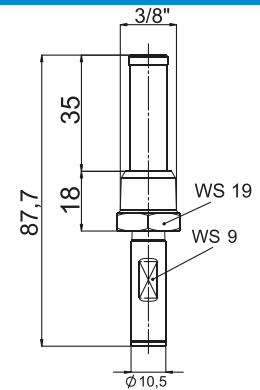

Spray Angle	Code	D mm	Flow rate (lpm) at different pressure values (bar)				
			10	30	50	70	140
0°	GMA 0380	0,38	0,21	0,36	0,47	0,56	0,79
	GMA 0500	0,50	0,36	0,62	0,80	0,95	1,35
	GMA 0630	0,63	0,57	0,99	1,27	1,51	2,13
	GMA 0760	0,76	0,82	1,42	1,83	2,17	3,07
	GMA 0810	0,81	0,92	1,59	2,06	2,43	3,44
	GMA 0890	0,89	1,10	1,91	2,46	2,91	4,12
	GMA 0910	0,91	1,22	2,11	2,73	3,23	4,56
	GMA 1010	1,01	1,50	2,60	3,35	3,97	5,61
	GMA 1220	1,21	2,10	3,64	4,70	5,56	7,86

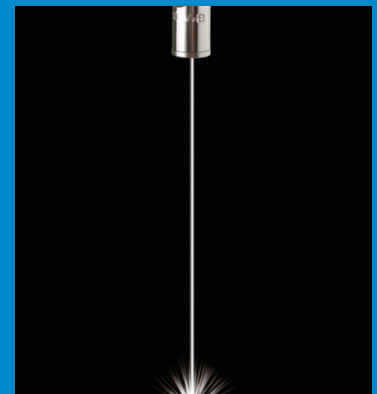

GDA

Spray Angle: 0°
Thread Size: 1/4"
 BSPT, 9/16-24 NEF
Materials: AISI 316L
 SS, ruby insert
Body Length:
 From 14,0 to 22,5 mm
Flow rate @ 3 bar:
 From 0,12 to 7,30 lpm

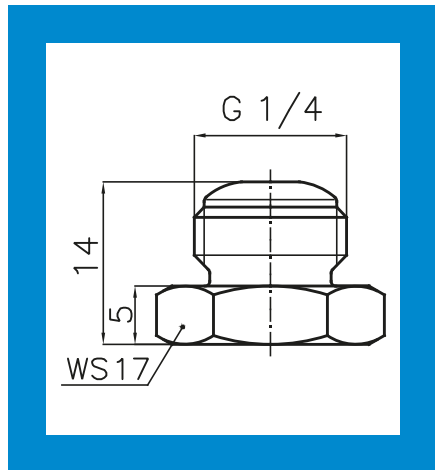

Spray Angle	Code	D mm	Flow rate (lpm) at different pressure values (bar)				
			3,0	5,0	10	30	50
0°	GDA 0120	0,35	0,12	0,15	0,22	---	---
	GDA 0170	0,40	0,17	0,22	0,31	0,54	0,69
	GDA 0290	0,50	0,29	0,37	0,53	0,92	1,18
	GDA 0420	0,70	0,42	0,54	0,77	1,33	1,71
	GDA 0500	0,80	0,50	0,65	0,91	1,58	2,04
	GDA 0780	0,90	0,78	1,01	1,42	2,47	3,18
	GDA 0890	1,00	0,89	1,15	1,62	2,81	3,63
	GDA 1120	1,10	1,20	1,55	2,19	3,79	4,90
	GDA 1450	2,40	4,50	5,81	8,22	---	---
	GDA 1730	3,20	7,30	9,42	13,3	---	---

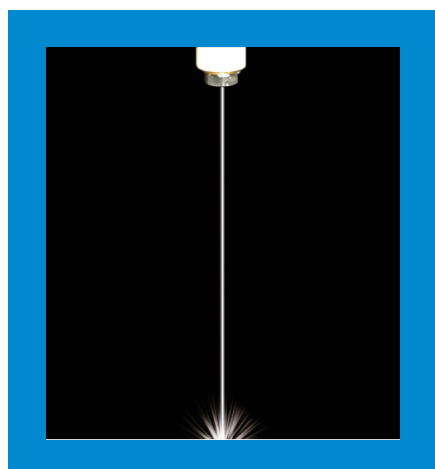

FBA

Spray Angle:
 0°
Thread Size:
 1/4"
Materials:
 AISI 416 SS
Flow rate @ 100 bar:
 From 3,40 to 135 lpm

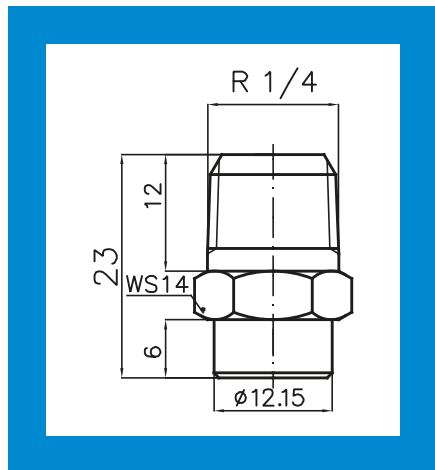

Spray Angle	Code	Flow rate (lpm) at different pressure values (bar)					
		20	30	50	70	100	150
0°	FBA 1340	1,52	1,86	2,40	2,84	3,40	4,16
	FBA 1686	3,10	3,70	4,80	5,70	6,80	8,40
	FBA 2103	4,60	5,60	7,20	8,60	10,3	12,6
	FBA 2138	6,10	7,50	9,70	11,4	13,8	19,3
	FBA 2170	7,60	9,40	12,0	14,2	17,0	24,0
	FBA 2226	9,70	11,9	15,3	18,1	22,6	31,0
	FBA 2280	12,7	15,6	20,0	24,0	28,0	40,0
	FBA 2360	16,3	20,0	26,0	31,0	36,0	52,0
	FBA 2682	31,0	37,0	48,0	57,0	68,2	97,0
	FBA 3135	61,0	75,0	97,0	114	135	193

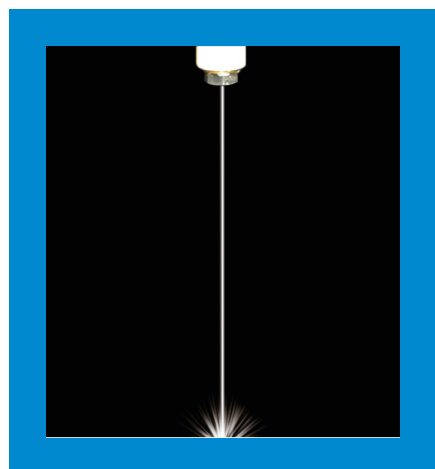

K

Spray Angle: 120°
 Thread Size (y):
 1/8" (y=G), 1/4" (y=H)
 Materials: Brass, AISI
 303 SS, AISI 316L SS
 Flow rate @ 3 bar:
 From 0,39 to 21,0 lpm

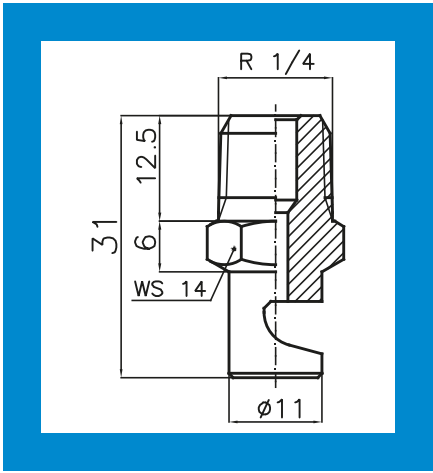

Spray Angle	Code	D mm	Flow rate (lpm) at different pressure values (bar)				
			0,5	1,0	2,0	3,0	4,0
120°	KGW 0390	0,60	0,16	0,23	0,32	0,39	0,45
	KGW 0780	0,80	0,32	0,45	0,64	0,78	0,90
	KyW 1160	1,10	0,65	0,92	1,31	1,60	1,85
	KyW 1230	1,40	0,94	1,33	1,88	2,30	2,66
	KyW 1390	1,80	1,59	2,25	3,18	3,90	4,50
	KyW 1590	2,30	2,41	3,41	4,82	5,90	6,81
	KyW 1780	2,60	3,18	4,50	6,37	7,80	9,01
	KyW 2117	3,30	4,78	6,75	9,55	11,7	13,5
	KyW 2157	3,80	6,41	9,06	12,8	15,7	18,1
KHW 2210	4,40	8,57	12,1	17,1	21,0	24,2	



J (std. capacity)

Spray Angle (x):
 60° (x=Q), 90° (x=U),
 120° (x=W)
 Thread Size (y):
 1/8" (y=A), 1/4" (y=B)
 Materials: Brass, AISI
 303 SS, AISI 316L SS
 Flow rate @ 3 bar:
 From 1,53 to 47,0 lpm

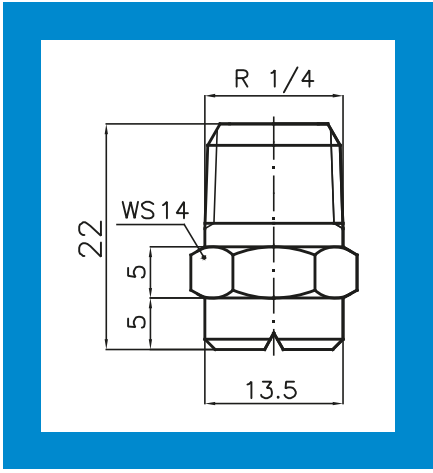

Spray Angle (x)	Code	D mm	Flow rate (lpm) at different pressure values (bar)				
			0,5	1,0	2,0	3,0	4,0
Q = 60° U = 90° W = 120°	Jyx 1153	1,25	0,62	0,88	1,25	1,53	1,77
	Jyx 1233	1,50	0,95	1,35	1,90	2,33	2,69
	Jyx 1385	1,80	1,57	2,22	3,14	3,85	4,45
	Jyx 1581	2,30	2,37	3,35	4,74	5,81	6,71
	Jyx 1780	2,70	3,18	4,50	6,37	7,80	9,01
	Jyx 1980	3,00	4,00	5,66	8,00	9,80	11,3
	Jyx 2153	3,80	6,25	8,83	12,5	15,3	17,7
	Jyx 2245	4,80	10,0	14,1	20,0	24,5	28,3
	Jyx 2310	5,40	12,7	17,9	25,3	31,0	35,8
Jyx 2470	6,20	19,2	27,1	38,4	47,0	54,3	



HT (std. capacity)

Spray Angle (x):

60° (x=Q), 80° (x=T),

95° (x=V)

Connection: Quick

Materials: Brass, AISI

303 SS, AISI 316L SS

Flow rate @ 3 bar:

From 7,80 to 78,0 lpm

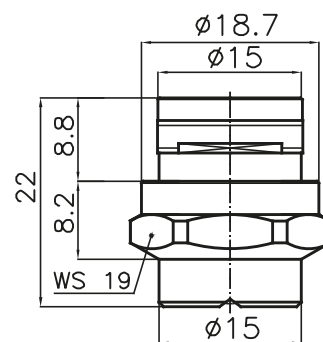

Spray Angle (x)	Code	D mm	Flow rate (lpm) at different pressure values (bar)				
			1,5	3,0	5,0	7,0	10
Q = 60° T = 80° V = 95°	HTx 1780	2,70	5,52	7,80	10,1	11,9	14,2
	HTx 1980	3,00	6,93	9,80	12,7	15,0	17,9
	HTx 2124	3,40	8,77	12,4	16,0	18,9	22,6
	HTx 2153	3,80	10,8	15,3	19,8	23,4	27,9
	HTx 2194	4,30	13,7	19,4	25,0	29,6	35,4
	HTx 2309	5,40	21,8	30,9	39,9	47,2	56,4
	HTx 2390	6,00	27,6	39,0	50,3	59,6	71,2
	HTx 2470	6,60	33,2	47,0	60,7	71,8	85,8
	HTx 2590	7,50	41,7	59,0	76,2	90,1	108
	HTx 2780	8,70	55,2	78,0	101	119	142



DRY END

In this section, we present nozzles and air blowers for use during the dry end phase. For every range, you will find some general information, a photo, a dimensional drawing, a picture of the spray and a table with the product performances. Please note that only a small part of the nozzles that PNR can manufacture and supply is on display.

To have a complete overview of our standard product range please visit our website www.pnr.eu or, if you have any special request, we invite you to write to info@pnr.it.

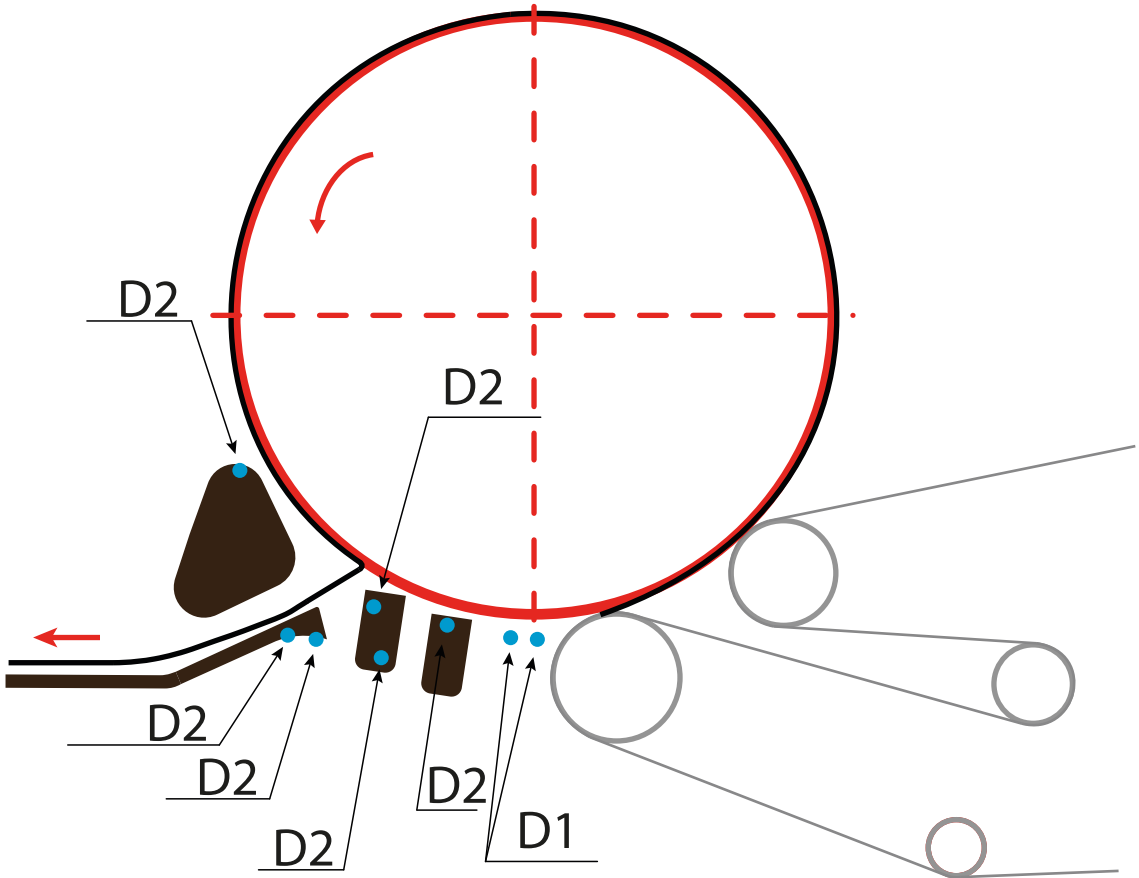

ITEM	DESCRIPTION	SHOWERS	TOTAL DELIVERY (lpm)	OP. PRESSURE (bar)	WATER TYPE	PNR NOZZLES
D1	Coating Shower	1	500	3	SF / F	HT
D2	Air Blowers	---	---	3	---	UEA, UEB

HT (low capacity)

Spray Angle (x):

60° (x=Q), 80° (x=T),

95° (x=V), 110° (x=J)

Connection: Quick

Materials: Brass, AISI 303 SS, AISI 316L SS

Flow rate @ 3 bar:

From 0,26 to 5,80 lpm

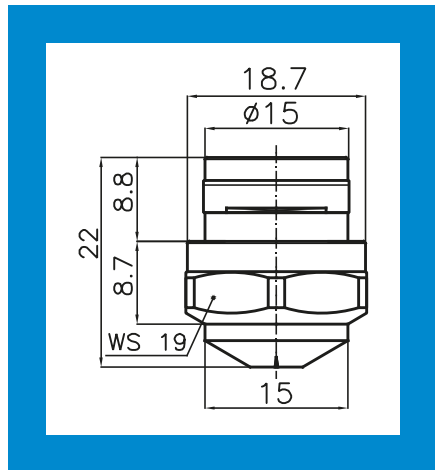

Spray Angle (x)	Code	D mm	Flow rate (lpm) at different pressure values (bar)				
			1,5	3,0	5,0	7,0	10
Q = 60° T = 80° V = 95° J = 110°	HTx 0260	0,50	0,18	0,26	0,34	0,40	0,47
	HTx 0390	0,63	0,28	0,39	0,50	0,60	0,71
	HTx 0590	0,81	0,42	0,59	0,76	0,90	1,08
	HTx 1160	1,01	1,13	1,60	2,07	2,44	2,92
	HTx 1190	1,19	1,34	1,90	2,45	2,90	3,47
	HTx 1230	1,47	1,63	2,30	2,97	3,51	4,20
	HTx 1310	1,70	2,19	3,10	4,00	4,74	5,66
	HTx 1385	1,85	2,72	3,85	4,97	5,88	7,03
	HTx 1490	2,10	3,46	4,90	6,33	7,48	8,95
HTx 1581	2,30	4,10	5,80	7,49	8,86	10,6	

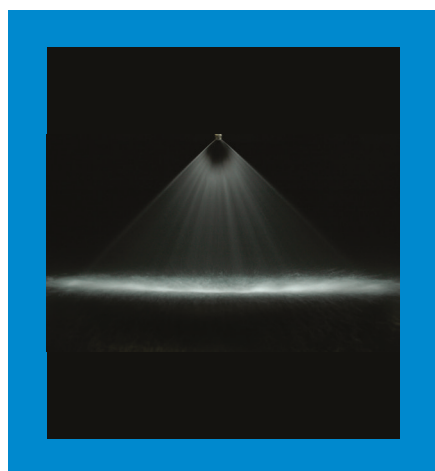

UEA

Connection:

1/4" - BSP, NPT

Materials:

AISI 316L SS

Acetalic resin (POM)

Aluminium, electroless nickel platerd

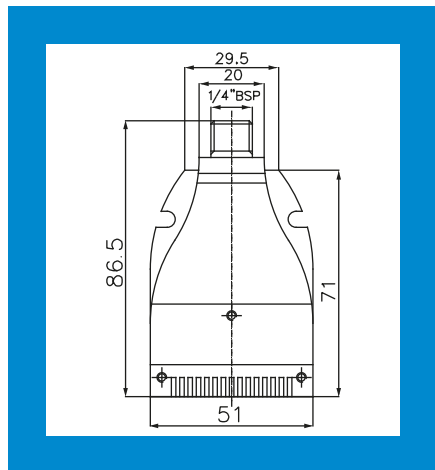

Code	Inlet inch	Air capacity (Nm3/h) at different pressure values (bar)				
		1,0	2,0	3,0	4,0	5
UEA 0525	1/4"	10,0	17,0	22,0	28,0	33,0
UEA 0527	1/4"	10,0	17,0	22,0	28,0	33,0

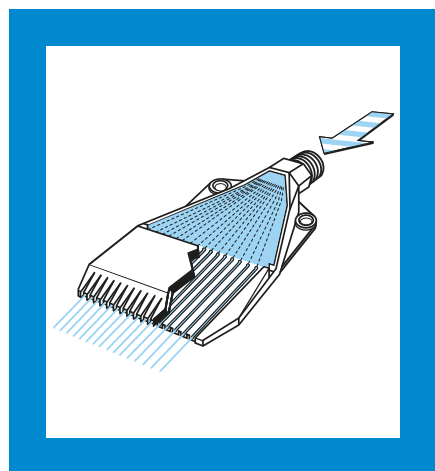

UEB

Connection:
1/4" - BSP, NPT

Lenght:
From 150 to 600 mm

Materials:
AISI 316L SS
Aluminium, electroless
nickel platerd

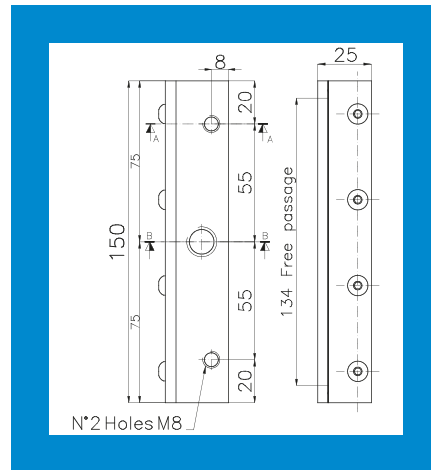

Code	Inlet		Air capacity (Nm3/min)					
	inch		IN	OUT	IN	OUT	IN	OUT
UEB 0150	1/4"		0,26	4,70	0,34	6,00	0,51	8,60
UEB 0300			0,52	9,40	0,68	12,0	1,02	17,2
UEB 0450			0,78	14,1	1,03	18,0	1,53	25,8
UEB 0600			1,03	18,7	1,40	24,0	2,04	34,4
Pressure (bar)			2,0		3,0		5,0	

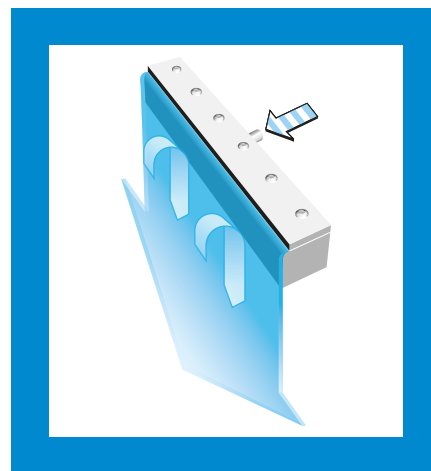

ACCESSORIES & FITTINGS

In this section, we show accessories and assembly fittings for a quick and easy installation of our nozzles. The first is a self-cleaning pipe, with its related dimensional drawing and a table with all different possible construction variations. Then the mixing eductors and, finally, wash-guns and hose reels, with a single illustrative picture due to the extremely wide variety of models we can produce and offer. If you have any special request, or if you want to have a complete view of all our accessories and fittings, we suggest you to visit our web site www.pnr.eu or write to info@pnr.it

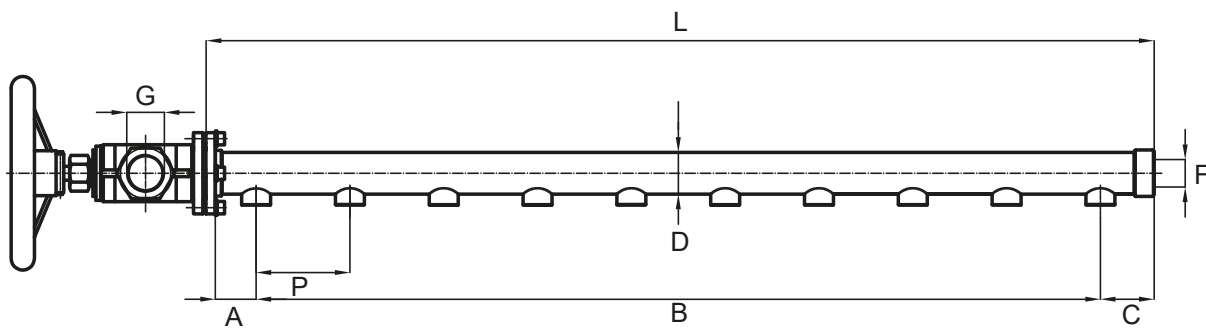

Self cleaning shower pipes are used in the pulp and paper industry for washing and cleaning forming fabrics and felt.

There are two kind of pipes:

1. Low pressure (2 ÷ 6 bar) fixed pipes with flat fan nozzles (PNR nozzle: GE).
2. High pressure (25 ÷ 70 bar) oscillating pipes with straight jet nozzles (PNR nozzle: GEA).

The table on the right shows the minimum and the maximum values for the pipes already produced. We are at your disposal for any request, please contact us at info@pnr.it.

	MIN	MAX
D	Ø 50 × 1,5	Ø 73 × 3
L	600	7.100
A	200	735
B	200	6.000
C	200	1.350
N	2	51
P	80	2.950
F	1-1/2" GF	2-1/2" GF
G	Ø 48	Ø 60

D, L, A, B, C, P are given in [mm]

UPB

Connection:
From 3/8" to 2"
BSPT, NPT

Materials:
AISI 316L SS
Glassfibers reinf. PP
PVDF

Flow rate @ 3 bar:
From 59,0 to 357 lpm

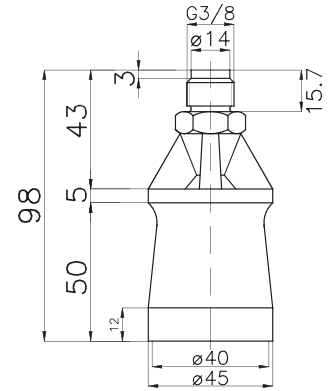

Code	Inlet	D	Flow rate (lpm) at different pressure values (bar)				
			1,0	2,0	3,0	4,0	5,0
	inch	mm					
UPB C070	3/8"	7,0	34,0	48,0	59,0	68,0	76,0
UPB E100	1/2"	10,0	63,0	89,0	109	126	141
UPB E100	3/4"	10,0	63,0	89,0	109	126	141
UPB H150	1-1/2"	15,0	155	220	268	310	346
UPB K200	2"	20,0	206	287	357	410	460

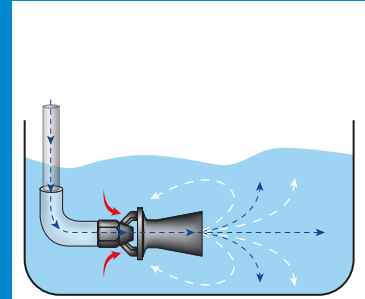

UPD

Connection:
From 3/4" to 2"
BSPT, NPT

Materials:
AISI 316L SS
Glassfibers reinf. PP
PVDF

Flow rate @ 3 bar:
From 109 to 357 lpm

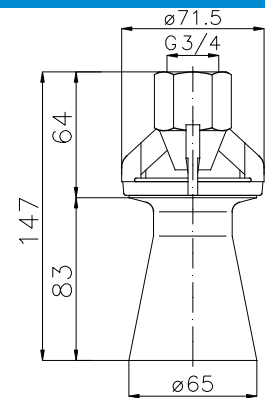

Code	Inlet	D	Flow rate (lpm) at different pressure values (bar)				
			1,0	2,0	3,0	4,0	5,0
	inch	mm					
UPD E100	3/4"	10,0	63,0	89,0	109	126	141
UPD H150	1-1/2"	15,0	141	199	243	281	313
UPD K200	2"	20,0	206	287	357	412	460

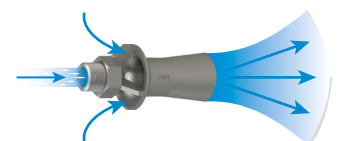



Pulp and paper plants must maintain a high level of cleanliness at all times and strict standards in manufacturing are required to comply with quality control procedures. In addition to our wide range of tank washers for inside cleaning of tanks and vats, we offer a line of products specially designed for efficient cleaning and sanitizing operations in production facilities. This includes:

- professional cleanings guns, max working pressure 350 bar, max working temperature 160 °C
- flexible hoses, up to 50 m, max working pressure 8 bar, max working temperature 160 °C
- hose reels, max working pressure 200 bar, max hose length 70 m

Contact us at info@pnr.it or www.pnr.eu/prodotti/accessories-fittings/ for further information.

As many of the products shown in this catalogue are available in different materials, their identification code in this catalogue is not complete: an alfa-numerical string that must be added to the product code identifies the construction material. The following alfa-numerical strings identify the most used materials:

B1: AISI 303 SS	D6: PP + 30% fiberglass	F30: Ruby insert on AISI 303 SS body
B31: AISI 316L SS	D82: PVDF KYNAR	F31: Ruby insert on AISI 316L SS body
C2: AISI 416 SS hardened	E1: PTFE	T1: Brass
C7: AISI 316Ti SS	E31: POM DELRIN	V7: Aluminium, electroless nickel plated
D1: PVC		

FIRE FIGHTING

Fire suppression systems are necessary to protect high-risk areas in pulp and paper mills where a fire or an explosion can occur, such as, in storehouses where flammable and finished products are stocked, or even in small rooms where dangerous materials like paints and lubricants are kept at hand. The FLOWTECH Group, to which PNR Italia belongs, also includes SDM Antincendio, company specialized in systems for fire protection and suppression. The highly qualified and experienced Staff of SDM will be happy to listen to your requirements for what concerns fire protection and fire-fighting needs.

NEW NOZZLE FOR FIRE PROTECTION OF LARGE SURFACE AREAS

SDM is expanding the wide range of its products with a new nozzle, specially designed and tested for a high efficiency protection of large surface areas.

This nozzle was originally designed for fire-fighting systems installed in highway and road tunnels, however, its special performances make it highly suitable for the fire protection of large surface areas such as storerooms, shopping malls, supermarkets and the like.

This unique design nozzle (patent pending) produces a fine water spray with an impressive flow rate of 150 litres per minute and requires a feed-water supply pressure of 5 bar only.

Therefore, this new nozzle offers the following advantages:

- 1) Cost-effective installation. One single nozzle can cover a round surface of 7-metre diameter, hence, a surface area of 40 square meters.
- 2) In many cases, an efficient fire protection can be achieved with a reduced number of nozzles and a low investment pump.
- 3) Fine sprays do not flood or damage stocked materials that can often be completely recovered.
- 4) The water mist spray evaporates quickly can mitigate the effects of an explosion and is often extremely effective for fire suppression.

You may look at a video showing this new nozzle in action in the SDM website.

CONTACTS

SDM Antincendio
Via dei Belcredi - Zona Artigianale Romera
Torricella Verzate (PV) - ITALY
Phone (+39) 0383.896239
Fax (+39) 0383.876316
Mail: info@sdmantincendio.com
Web site: www.sdmantincendio.com

PNR ITALIA

Incorporated in 1968, PNR has always been active in the design and manufacture of spraying nozzles and systems for industrial applications. In all these years, PNR has made major investments both in machinery and human resources to develop top quality products and today is one of the most modern spray nozzles manufacturing facilities in the world. We manufacture thousands of different products and can offer our customers one of the most complete portfolios in the world, while staying focused on research and innovation. Our production machines and tools include latest generation CNC turning machines, many of them built to our requirements to accomplish special manufacturing processes. All products and their performance are strictly controlled throughout the whole production process, and our quality management system is certified to ISO 9001.

PRODUCT WARRANTY

PNR products will be replaced or repaired at the option of PNR and free of charges if found defective in manufacturing, labelling and packaging. The above conditions will apply if notice of defects is received by PNR within 30 days from date of product installations or one year from date of shipment. The cost of above said replacement or repair shall be the exclusive remedy for any breach of any warranty, and PNR shall not be held liable for any damage due to personal injuries or commercial losses coming from product malfunction. It is self-understood that no warranty may apply in case our products have been operated under nonacceptable conditions, like for example (but not limited to):

- Operation at pressures exceeding those shown in catalogue performance table
- Operation with or exposure to liquids containing abrasive particles
- Operation with or exposure to liquids producing a chemical attack on the nozzle material
- Mechanical damages to nozzle orifices, nozzle spray edge or body due to careless handling or assembling.

In all above cases, the customer must accept a nozzle life reduction below life expected, or performance parameters below the values in the catalogue. The guarantee may be exercised as follows:

- By sending a precautionary report to PNR on the detected damages. This report can also be sent by email to this address: quality@pnr.it
- If PNR ascertains that the manufacturing faults are actually subject to the warranty, the product shall have to be returned to the manufacturer in its original packaging prior request of authorization to the manufacturer and receipt of manufacturer's written authorization.
- The rejected goods shall have to be returned by the means that PNR will communicate to the customer and the transportation costs of returned merchandise will be entirely borne by the manufacturer.

DISCLAIMER

Our products are manufactured with the best care and according to the latest developments of the technology available. However we cannot assure that every one of our products is perfectly fit for every specific application. The information in this catalogue is provided "as seen" and so we offer no warranty of any kind with respect to the subject matter or accuracy of the information contained herein. This publication may include technical inaccuracies or typographical errors and changes may be periodically made to the information herein without prior notice.

A GLOBAL PRESENCE

PNR Italia sells its products directly from Italy and through a global network of sales subsidiaries and authorized distributors located in:

Argentina
Australia
Austria
Belgium
Canada
China
Croatia
Denmark
Finland
France
Germany
Greece
Hungary
India
Indonesia
Ireland
Korea
Mexico
Norway
Poland
Portugal
Romania
Russia
Singapore
Slovenia
South Africa
Spain
Sweden
Taiwan
The Netherlands
Turkey
UK
United States



PNR Italia srl
Via Gandini, 2
27058 VOGHERA (PV)
ITALIA

Tel: 0383 344 611
Fax: 0383 212 489
Email: info@pnr.it
PEC: pnr@pec.it

www.pnr.eu