



# SPRAY NOZZLES FOR INDUSTRIAL APPLICATIONS



**SPRAY NOZZLES &  
ASSEMBLY FITTINGS**  
GENERAL CATALOGUE

# PNR ITALIA

## SPRAY NOZZLES FOR INDUSTRIAL APPLICATIONS

PNR ITALIA manufactures and markets small spraying nozzles for individual use up to spraying systems for large industrial plants and is able to meet every customer's need with targeted solutions.

The wide range of products includes spray nozzles, washing heads and complementary accessories such as filters, guns and hoses for industrial washing, ejectors, blow nozzles, joints and hose clamps.

Located in Voghera, not far from Milan, the Headquarter and production plant is located in a strategic area favored by the proximity to the main motorway networks and important international maritime routes, easily accessible from the port of Genoa.

PNR ITALIA started its activity in 1968 with the trade and production of components and spraying nozzles for fire protection systems and, subsequently, with a range of sprayers for industrial applications. Over time it has grown and consolidated through a commercial policy based on a widespread network of partners present in the main foreign markets and also thanks to a continuous investment in research.

Today PNR ITALIA has at its disposal a technologically advanced production plant for the production of spraying nozzles, washing heads and atomizers with absolute quality machines, many of which work with CNC technology, often internally designed for special machining.

With an annual production of about 9 million pieces, PNR ITALIA is a solid industrial reality oriented to constant growth, driven by high-tech investments and product innovation.



# CONTENT

3	INDEX
10	SPRAY TECHNOLOGY
15	SPRAY PATTERNS
17	FULL CONE NOZZLES
42	FLAT FAN NOZZLES
66	HOLLOW CONE NOZZLES
77	STRAIGHT JET NOZZLES
83	AIR BLOWING NOZZLES
86	ASSEMBLY ACCESSORIES
90	PRESSURE TANKS AND FILTERS
103	CLIP-ON NOZZLES
115	GENERAL INFORMATION



*PNR Italia Headquarters - Voghera (PV)*



# FULL CONE NOZZLES



## AA SHORT BODY

- Thread size: 3/4" ~ 3"
- Spray angle: 90°, 120°
- Capacity: 30.5 ~ 775 l/min
- Materials:  
AISI 303, AISI 316L, Brass

P.19



## AE FLANGE

- Flange size: 80 ~ 250mm
- Spray angle: 90°, 120°
- Capacity: 940 ~ 9410 l/min
- Materials:  
AISI 316L, Cast iron, Carbon steel

P.20



## AH FINE MIST

- Thread size: 1/4" ~ 1/2"
- Spray angle: 65°, 80°
- Capacity: 2.07 ~ 15.4 l/min
- Materials:  
AISI 303, AISI 316L, Brass

P.21



## AL NON CLOGGING

- Thread size: 3/8" ~ 2"
- Spray angle: 60°, 90°, 120°
- Capacity: 9.27 ~ 2780 l/min
- Material:  
AISI 316L, PP, PVDF

P.22



## AT TANGENTIAL

- Thread size: 1/8" ~ 1"
- Spray angle: 60°, 90°, 120°
- Capacity: 2.30 ~ 122 l/min
- Materials:  
AISI 303, AISI 316L, Brass

P.23



## BA CLEANABLE

- Thread size: 1/8" ~ 1/2"
- Spray angle: 60°, 120°
- Capacity: 0.74 ~ 36 l/min
- Materials:  
AISI 303, AISI 316L, Brass, PTFE, Hastelloy C 22

P.24



## BB CLEANABLE

- Thread size: 1/8" ~ 1/2"
- Spray angle: 60°
- Square spray pattern
- Capacity: 2.7 ~ 27 l/min
- Materials:  
AISI 303, AISI 316L, Brass

P.25



## BC CLEANABLE

- Thread size: 1/8" ~ 1/2"
- Spray angle: 60°, 120°
- Capacity: 0.74 ~ 36 l/min
- Materials:  
AISI 303, AISI 316L, Brass, PTFE, Hastelloy C22

P.24



## BD CLEANABLE

- Thread size: 1/8" ~ 1/2"
- Spray angle: 60°
- Square spray pattern
- Capacity: 2.7 ~ 27 l/min
- Materials:  
AISI 303, AISI 316L, Brass

P.25



## BE LARGE CAPACITY

- Thread size: 3/4" ~ 8"
- Spray angle: 50° ~ 120°
- Capacity: 22 ~ 7850 l/min
- Materials:  
AISI 303, AISI 316L, Brass, PTFE, Hastelloy C22

P.27



## BF LARGE CAPACITY

- Thread size: 3/4" ~ 6"
- Spray angle: 80° ~ 115°
- Capacity: 50 ~ 4200 l/min
- Materials:  
AISI 303, AISI 316L, Brass, PVC, PTFE

P.26



## BG LOW CAPACITY

- Thread size: 1/4" ~ 1 1/2"
- Spray angle: 60°, 120°
- Capacity: 4.8 ~ 200 l/min
- Materials:  
AISI 303, AISI 316L, Brass, PTFE, Hastelloy C22

P.27



## BH SMALL CAPACITY

- Thread size: 1/8" ~ 1"
- Spray angle: 60°, 120°
- Square spray pattern
- Capacity: 2.7 ~ 93 l/min
- Materials:  
AISI 303, AISI 316L, Brass, PVC, PTFE

P.26



## BL LARGE CAPACITY

- Thread size: 4" ~ 10"
- Spray angle: 90°
- Capacity: 1390 ~ 11300 l/min
- Materials:  
AISI 316L, Cast iron, Carbon steel

P.28



## BR NARROW SPRAY

- Thread size: 1/8" ~ 3/4"
- Spray angle: 15°, 30°
- Capacity: 0.98 ~ 35.2 l/min
- Materials:  
AISI 303, AISI 316L, Brass, PTFE, PVC, PP

P.29



## BS NARROW SPRAY

- Thread size: 1/8" ~ 3/4"
- Spray angle: 15°, 30°
- Capacity: 0.98 ~ 35.2 l/min
- Materials:  
AISI 303, AISI 316L, Brass, PTFE, PVC, PP

P.29



## BT NARROW SPRAY

- Thread size: 1" ~ 2 1/2"
- Spray angle: 30°
- Capacity: 27 ~ 470 l/min
- Materials:  
AISI 303, AISI 316L, Brass, PTFE, PVC, PP

P.29



## BV TANGENTIAL

- Thread size: 1/8" ~ 1/2"
- Spray angle: 60°, 120°
- Capacity: 1.5 ~ 36 l/min
- Materials:  
AISI 303, AISI 316L, Brass

P.30



## BW TANGENTIAL

- Thread size: 1/8" ~ 1/2"
- Spray angle: 60°, 120°
- Capacity: 1.5 ~ 36 l/min
- Materials:  
AISI 303, AISI 316L, Brass

P.30



## BX THREE-PIECE

- Spray angle: 60°
- Capacity: 1.49 ~ 7.43 l/min
- Materials:  
AISI 303, AISI 316L, Brass

P.31



## BJ BX / SISTER PRODUCTS

- Thread size: 3/8"
- Spray angle: 60°
- Capacity: 1.49 ~ 7.43 l/min
- Materials:  
AISI 303, AISI 316L, Brass

P.31



# FULL CONE NOZZLES

**CAS**  
**CLUSTER NOZZLE**  
**STANDARD SPRAY**



- Thread size: 1/2" ~ 2"
- Spray angle: 70°
- Capacity: 1.53 ~ 245 l/min
- Materials: AISI 303, AISI 316L, Brass, Nickel plated brass

P.33

**CAY**  
**CLUSTER NOZZLE**  
**WIDE SPRAY ANGLE**



- Thread size: 1/2" ~ 2"
- Spray angle: 130°
- Capacity: 1.53 ~ 490 l/min
- Materials: AISI 303, AISI 316L, Brass

P.34

**CH**  
**7 / 13 CLUSTER NOZZLE**



- Thread size: 3/4" ~ 2"
- Spray angle: 200°, 360°
- Capacity: 8.26 ~ 481 l/min
- Materials: AISI 303, AISI 316L, Brass

P.32

**D**  
**TWO-PIECE**



- Thread size: 1/8" ~ 1/2"
- Spray angle: 45°, 60°, 90°, 120°
- Capacity: 0.78 ~ 37 l/min
- Materials: AISI 303, AISI 316L, Brass

P.35

**D**  
**LARGE CAPACITY**



- Thread size: 3/4" ~ 4"
- Spray angle: 60°, 90°, 120°
- Capacity: 23.5 ~ 1470 l/min
- Materials: AISI 303, AISI 316L, Brass

P.37

**Dplus**  
**ANTI-OCCCLUSION**



- Thread size: 1/8" ~ 1/2"
- Spray angle: 45°, 60°, 90°, 120°
- Capacity: 1.18 ~ 29.4 l/min
- Materials: AISI 303, AISI 316L, Brass

P.39

**E**  
**SPIRAL NOZZLE**



- Thread size: 1/4" ~ 4"
- Spray angle: 60°, 90°, 120°, 150°, 180°
- Capacity: 5.5 ~ 4120 l/min
- Materials: AISI 316L, Brass, PP, PVC, PTFE, PVDF, Hastelloy C22

P.41

**E-X**  
**SPIRAL NOZZLE**



- Thread size: 3/8" ~ 4"
- Spray angle: 120°
- Capacity: 23.5 ~ 4120 l/min
- Materials: AISI 316L, Brass, PP, PVC, PTFE, PVDF, Hastelloy C22

P.43

**ES**  
**SILICON CARBIDE**



- Spray angle: 90°, 120°, 150°
- Capacity: 23.5 ~ 4120 l/min
- Material: Silicon carbide

P.45

# STRAIGHT JET NOZZLES

**F**  
**HIGH IMPACT**



- Thread size: 1/8", 1/4"
- Spray angle: 0°
- Capacity: 3.4 ~ 68.2 l/min (100 bar)
- Material: AISI 416

P.80

**GDA**  
**NEEDLE JET NOZZLE**



- Thread size: 1/4", 9/16-24NEF
- Spray angle: 0°
- Capacity: 0.12 ~ 7.3 l/min (10bar)
- Materials: AISI 303 / AISI 316L (with ruby insert)

P.81

**GEA**  
**DISC NOZZLE**



- Spray angle: 0°
- Capacity: 0.17 ~ 3.1 l/min
- Materials: AISI 303 with ruby insert, AISI 316L with ruby insert, AISI 316Ti

P.66

**GFA**  
**SELF-CLEANING NOZZLE**



- Spray angle: 0°
- Capacity: 1.0 ~ 3.3 l/min
- Material: AISI 316L

P.67

**GMA**  
**PAPER WEB TRIMMERS**



- Thread size: 3/8"
- Spray angle: 0°
- Capacity: 0.08 ~ 2.2 l/min
- Materials: AISI 303 with ruby insert, AISI 316L with ruby insert

P.82

**J**  
**GENERAL PURPOSE**



- Thread size: 1/8", 1/4"
- Spray angle: 0°
- Capacity: 0.17 ~ 47 l/min
- Materials: AISI 303, AISI 316L, Brass, AISI 316L with ruby insert, AISI 316L with diamond insert

P.83

# FLAT FAN NOZZLES



**F**  
**HIGH IMPACT**

- Thread size: 1/8" ~ 1/4"
- Spray angle: 0°, 15°, 25°, 40°, 65°
- Capacity: 3.40 ~ 135 l/min (100 bar)
- Material: AISI 416

P.47



**FX**  
**HIGH IMPACT**

- Spray angle: 0°, 15°, 25°, 40°, 65°
- Capacity: 3.40 ~ 68.2 l/min (100 bar)
- Material: AISI 416

P.47



**GA**  
**SHORT BODY**

- Thread size: 1/4", 3/4"
- Spray angle: 45°, 60°, 90°, 120°
- Capacity: 3.10 ~ 76 l/min
- Materials: AISI 303, AISI 316L, Brass, PVC, PP, PTFE

P.49



**GE**  
**DISC NOZZLES**

- Spray angle: 60°, 75°
- Capacity: 0.90 ~ 23.0 l/min
- Materials: AISI 316Ti

P.66



**GF**  
**SELF CLEANING NOZZLES**

- Spray angle: 0° ~ 80°
- Capacity: 1.0 ~ 13.9 l/min
- Material: AISI 316L

P.67



**GX**  
**LOW CAPACITY**

- Spray angle: 25° ~ 110°
- Capacity: 0.06 ~ 1.6 l/min
- Materials: AISI 303, AISI 316L, Brass

P.50



**GX**  
**STD / LARGE CAPACITY**

- Spray angle: 0° ~ 120°
- Capacity: 1.90 ~ 122 l/min
- Materials: AISI 303, AISI 316L, Brass, PVDF

P.51



**GY**  
**FIXED ORIENTATION**

- Spray angle: 0° ~ 120°
- Capacity: 1.90 ~ 122 l/min
- Materials: AISI 303, AISI 316L, Brass

P.53



**HT**  
**QUICK CONNECTION**

- Thread size: 1/4", 3/8"
- Spray angle: 0° ~ 110°
- Capacity: 0.26 ~ 78 l/min
- Materials: AISI 303, AISI 316L, Brass

P.55



**J**  
**LOW CAPACITY**

- Thread size: 1/8", 1/4"
- Spray angle: 25° ~ 110°
- Capacity: 0.06 ~ 1.6 l/min
- Materials: AISI 303, AISI 316L, Brass

P.56



**J**  
**STANDARD CAPACITY**

- Thread size: 1/8" ~ 3/8"
- Spray angle: 0° ~ 120°
- Capacity: 1.53 ~ 47 l/min
- Materials: AISI 303, AISI 316L, Brass, PVC, PTFE

P.57



**J**  
**LARGE CAPACITY**

- Thread size: 1/2" ~ 1"
- Spray angle: 0° ~ 95°
- Capacity: 19.5 ~ 435 l/min
- Materials: AISI 303, AISI 316L, Brass

P.60



**K**  
**LARGE SPRAY ANGLE**

- Thread size: 1/8" ~ 1"
- Spray angle: 90° ~ 140°
- Capacity: 0.39 ~ 350 l/min
- Materials: AISI 303, AISI 316L, Brass

P.61



**K**  
**HIGH IMPACT**

- Thread size: 1/8" ~ 3/4"
- Spray angle: 15° ~ 50°
- Capacity: 1.60 ~ 78 l/min
- Materials: AISI 303, AISI 316L, Brass

P.63



**KHT**  
**HIGH IMPACT**

- Thread size: 1/4" ~ 1/2"
- Spray angle: 35°
- Capacity: 23 ~ 31 l/min
- Materials: AISI 303, AISI 316L, Brass

P.63



**KX**  
**LARGE SPRAY ANGLE**

- Spray angle: 90° ~ 140°
- Capacity: 0.39 ~ 31 l/min
- Materials: AISI 303, AISI 316L, Brass

P.61



**SHOWER PIPE**

P.65

# HOLLOW CONE NOZZLES



**PA**  
**LARGE CAPACITY**

- Thread size: 3/8" ~ 2-1/2"
- Spray angle: 70°, 90°
- Capacity: 1.70 ~ 605 l/min
- Materials: AISI 316L, Brass

P.71



**PB**  
**LARGE CAPACITY**

- Thread size: 3/8" ~ 2-1/2"
- Spray angle: 130°
- Capacity: 3.90 ~ 665 l/min
- Materials: AISI 316L, Brass

P.71



**PE**  
**STANDARD CAPACITY**

- Thread size: 1/8" ~ 3/4"
- Spray angle: 70°, 120°
- Capacity: 0.39 ~ 63 l/min
- Materials: AISI 303, AISI 316L, Brass

P.69



**PF**  
**STANDARD CAPACITY**

- Thread size: 1/8" ~ 3/4"
- Spray angle: 50° ~ 120°
- Capacity: 0.39 ~ 94 l/min
- Materials: AISI 303, AISI 316L, Brass

P.69



**PN**  
**MOULDED PLASTIC**

- Thread size: 3/8" ~ 1/2"
- Spray angle: 60° ~ 130°
- Capacity: 1.70 ~ 42 l/min
- Material: Fiberglass reinforced PP

P.72



**PO**  
**MOULDED PLASTIC**

- Thread size: 3/8"
- Spray angle: 60° ~ 130°
- Capacity: 1.70 ~ 22 l/min
- Material: Fiberglass reinforced PP

P.72



**PR**  
**LARGE CAPACITY**

- Thread size: 3", 4"
- Spray angle: 130°
- Capacity: 612 ~ 3850 l/min
- Materials: AISI 316L, Cast Iron

P.73



**PS**  
**MOULDED PLASTIC**

- Thread size: 3/8"
- Spray angle: 60° ~ 130°
- Capacity: 1.70 ~ 22 l/min
- Material: Fiberglass reinforced PP

P.72



**PT**  
**QUICK CONNECTION**

- Thread size: 1/4" ~ 1/2"
- Spray angle: 50° ~ 120°
- Capacity: 0.78 ~ 47 l/min
- Materials: AISI 303, AISI 316L, Brass

P.69



**RA**  
**FINE SPRAY  
SMALL PASSAGES**

- Thread size: 1/8" ~ 1/2"
- Spray angle: 60° ~ 90°
- Capacity: 0.20 ~ 19.6 l/min
- Materials: AISI 303, AISI 316L, Brass

P.74



**RB**  
**FINE PRAY  
CLOG RESISTANT**

- Thread size: 3/8" ~ 1-1/2"
- Spray angle: 60° ~ 80°
- Capacity: 1.60 ~ 94 l/min
- Materials: AISI 303, AISI 316L, Brass

P.75



**RC**  
**EXTRA WIDE  
SPRAY ANGLE**

- Thread size: 1/4", 3/8"
- Spray angle: 150°, 180°
- Capacity: 7.80 ~ 39 l/min
- Materials: AISI 303, AISI 316L, Brass

P.76



**RO**  
**NON CLOGGING**

- Thread size: 1/2", 3/4"
- Spray angle: 130°
- Capacity: 8.1 ~ 164 l/min
- Materials: AISI 316L, Brass, Ni-plated brass (chemical)

P.77



**RW**  
**LOW CAPACITY**

- Tip + nipple + locknut
- Spray angle: 80°
- Capacity: 3.6 ~ 99.6 l/hour
- Materials: AISI 303, AISI 316L, Brass

P.78



**RX**  
**LOW CAPACITY**

- Thread size: 1/4"
- Spray angle: 80°
- Capacity: 3.6 ~ 99.6 l/hour
- Materials: AISI 303, AISI 316L, Brass

P.78



**RZ**  
**LOW CAPACITY**

- Thread size: 1/4"
- Spray angle: 30° ~ 90°
- Capacity: 0.08 ~ 2.0 l/min
- Materials: AISI 303, AISI 316L, Brass

P.78



# AIR BLOWING NOZZLES MIXING EDUCTORS

## AIR BLOWING NOZZLES



### GZS

#### AIR & STEAM FLAT FAN TIPS

- Thread size: 1/4"
- Spray angle: 70°
- Capacity: 3 ~ 31.5 Nm<sup>3</sup>/hour (2 bar)
- Materials: AISI 303, AISI 316L, Brass

P.84



### UEA D020

#### AIR BLOW-OFF NOZZLES

- Thread size: 1/4"
- Spray angle: 20°
- Capacity: 20 Nm<sup>3</sup>/hour (3 bar)
- Materials: Electroless Ni-plated aluminum, AISI 316L

P.85



### UEA 0525

#### AIR BLOW-OFF NOZZLES

- Thread size: 1/4"
- Spray width: 48 mm
- Capacity: 22 Nm<sup>3</sup>/hour (3 bar)
- Material: POM

P.85



### UEA 0527

#### AIR BLOW-OFF NOZZLES

- Thread size: 1/4"
- Spray width: 51 mm
- Capacity: 22 Nm<sup>3</sup>/hour (3 bar)
- Materials: Electroless Ni-plated aluminum, AISI 316L

P.85



### UEB

#### HIGH-EFFECT AIR KNIVES

- Thread size: 1/4"
- Length: 150 ~ 600mm
- Air capacity: 0.51~2.04 Nm<sup>3</sup>/min (5 bar)
- Materials: Electroless Ni-plated aluminum, AISI 316L

P.86

## MIXING EDUCTORS



### UPB

#### MIXING EDUCTORS

- Thread size: 3/8" ~ 2"
- Capacity: 59 ~ 357 l/min
- Materials: AISI 316L, PVDF, Fiberglass reinforced PP

P.87



### UPD

#### MIXING EDUCTORS

- Thread size: 3/4" ~ 2", 1/4"
- Capacity: 109 ~ 357 l/min
- Materials: AISI 316L, Fiberglass reinforced PP

P.87

# ASSEMBLY ACCESSORIES



### VAA

#### LOCKNUT

- Thread size: 3/8", 3/4", 1-1/4"
- Materials: AISI 303, AISI 316, Brass, Fiberglass reinforced PP

P.90



### ZAA

#### STANDARD WELDING NIPPLES

- Thread size: 3/8", 3/4"
- Materials: AISI 303, AISI 316L, PP, PVDF

P.91



### ZAC

#### DOVE-TAIL WELDING NIPPLES

- Thread size: 3/8", 3/4", 1-1/4"
- Material: AISI 303, AISI 316L, PP, PVDF

P.91



### ZLA

#### STANDARD THREADED NIPPLES

- Thread size: 1/8" ~ 1/2"
- Materials: AISI 303, AISI 316L, Brass, PVC, PP, PVDF

P.91



### ZPB

#### PLASTIC PIPE CLAMPS

- Pipe size: 1/2" ~ 1-1/4"
- Body: Fiberglass reinforced PP
- O-ring: NBR
- Metal Parts: AISI 304

P.88



### ZPC

#### PLASTIC BAYONET PIPE CLAMPS

- Pipe size: 1/2"
- Body: PVDF
- O-ring: VITON
- Material: AISI 316

P.88



### ZPH

#### DISK NOZZLE PIPE CLAMP

- Pipe external diameter: 2"
- Body: Fiberglass reinforced PP
- O-ring: EPDM
- Pin, bolt: AISI 316

P.90



### ZPM

#### METAL PIPE CLAMPS

- Pipe size: 1/2" ~ 2-1/2"
- Body: AISI 304, Zinc coated steel
- Gasket: EPDM
- Nipple: AISI 316L, Brass

P.89

# FILTERS / SPRAY GUNS / HOSE REELS / TANKS

## FILTERS



**VED**  
**CHECK-VALVE FILTERS**

- Suitable nozzle tip: GX, FX, BX, KX
- Mesh number: 50, 80, 100 Mesh
- Body: AISI 303, AISI 316L, Brass, Nylon
- Wire net: AISI 304

P.94



**VEL**  
**BRASS BODY FILTERS**

- Thread size: 3/8" ~ 2"
- Mesh number: 150 Mesh
- Body: Nickel plated Brass
- Cartridge: AISI 304
- Seal: EPDM

P.95

## SPRAY GUNS



**UMW**  
**HIGH PRESSURE GUNS**

- Inlet thread: 3/8"
- Outlet thread: 1/4"
- Body: AISI 303, Brass
- Outside shell: Nylon, glassfibers reinforced

P.97

## REWIND REELS / PRESSURE TANKS



**UMR**  
**PRESSURE TANKS**

- Body: AISI 304
- Base: Synthetic rubber
- Capacity: 9, 18 Liters
- LP: 4.9 bar

P.92



**VEA**  
**HAT FILTERS**

- Suitable nozzle tip: GX, FX, BX, KX
- Mesh number: 50, 75, 100 Mesh
- Collar: Copper + AISI 316
- Wire net: AISI 316L

P.93



**VEF**  
**THREADED FILTERS**

- Suitable nozzle tip: J, RW, RX, RZ
- Mesh number: 50, 75, 100 Mesh
- Body: AISI 303, AISI 316(L), Brass
- Wire net: AISI 304

P.93



**VEM**  
**LARGE CAPACITY FILTERS**

- Thread size: 1/2" ~ 3"
- Mesh number: 30, 60, 80 Mesh
- Body: Aluminum casting
- Wire net: AISI 304
- Seal: EPDM

P.96



**UMS**  
**PORTABLE WATER GUNS**

- Inlet thread: 1/2"
- Outlet thread: 1/2"
- Material: Acetalic resin

P.100



**XUM**  
**FLEXIBLE HOSE**

- Hose: EPDM
- Couplings: AISI 316

P.100



**UMU A / B**  
**MANUAL REWIND REELS**

- Flexible hose size: 3/8" ~ 1"
- Material: AISI 304

P.101



**UMU L / K**  
**AUTO-REWIND & ORIENTABLE OUTLET REELS**

- Flexible hose size: 1/2" ~ 1"
- Material: AISI 304

P.102



**VEC**  
**FLANGED FILTERS**

- Suitable nozzle tip: GX, FX, BX, KX
- Mesh number: 50, 75, 100 Mesh
- Body: AISI 303, AISI 316L, Nylon
- Wire net: Brass, AISI 304

P.93



**VEH**  
**PLASTIC BODY FILTERS**

- Thread size: 1/2" ~ 1-1/2"
- Mesh number: 32, 50, 100 Mesh
- Body: PP
- Wire net: AISI 304
- Seal: EPDM

P.95



**VEQ**  
**"Y" STYLE FILTERS**

- Thread size: 1/2", 3/4", 1"
- Mesh number: 60 Mesh
- Body: Fiberglass reinforced PP
- Wire net: AISI 304
- Seal: EPDM

P.96



**UMV**  
**HOT WATER SPRAY GUNS**

- Thread size: 1/2"
- Body: AISI 316, Brass casting chrome plated
- Outside shell: EPDM

P.99



**UMU G / H**  
**AUTO-REWIND REELS**

- Flexible hose size: 3/8" ~ 1"
- Material: AISI 304

P.101



**UMU J / I**  
**LARGE CAPACITY AUTO-REWIND REELS**

- Flexible hose size: 1/2" ~ 1"
- Material: AISI 304

P.102

# CLIP-ON NOZZLES



**DT/QM FULL CONE NOZZLES**  
**HT/QM FLAT FAN NOZZLES**

- Quick-fit
- Spray angle: 45° ~ 120°
- Capacity: 0.78 ~ 28.0 l/min
- Material: Fiberglass reinforced PP

P.110



**HG FLAT FAN NOZZLES**

- Spray angle: 60°
- Capacity: 2.3 ~ 23.7 l/min
- Material: Fiberglass reinforced PP Talcum filled PP

P.111



**HT/QQ FLAT FAN NOZZLES**

- Quick-fit
- Spray angle: 60°
- Capacity: 2.3 ~ 15.8 l/min
- Material: Fiberglass reinforced PP AISI 316L

P.112



**KS/QQ FLAT FAN NOZZLES**

- Quick-fit
- Spray angle: 50°, 60°
- Capacity: 8.9 ~ 25 l/min
- Body: Fiberglass reinforced PP

P.112



**RG HOLLOW CONE NOZZLES**

- Spray angle: 50°
- Capacity: 10.1 ~ 22.5 l/min
- Material: Fiberglass reinforced PP Talcum filled PP

P.111



**VAB LOCKNUTS**

- Body: Fiberglass reinforced PP

P.107



**VAE LOCKNUTS**

- Material: Fiberglass reinforced PP

P.108



**ZBA THREADED / QUICK-FIT SPHERE**

- Ideal for: HT/QQ, KS/QQ
- Thread size: 1/4", 3/8", 1/2"
- Angle of rotation: 60°
- Material: Fiberglass reinforced PP

P.108



**ZLF THREADED NIPPLE**

- Thread size: 3/8", 1/2"
- Material: Fiberglass reinforced PP

P.108



**ZPF SWIVEL NOZZLE CLAMPS**

- Thread size: 1 1/4", 1 1/2"
- Body: Fiberglass reinforced PP
- O-ring: NBR
- Pin & bolt: AISI 316

P.106



**ZPG PIPE HOLDERS**

- Thread size: 3/4" ~ 2"
- Body: Fiberglass reinforced PP
- Spring: AISI 302

P.113



**ZPL SPRING PIPE CLAMPS**

- Thread size: 1", 1 1/4", 1 1/2", 2"
- Body: Fiberglass reinforced PP
- O-ring: NBR
- Spring: AISI 302, AISI 316L

P.107



**ZPN SPRING PIPE CLAMPS**

- Thread size: 1/8" ~ 1/2"
- Body: Fiberglass reinforced PP
- O-ring: NBR
- Spring: AISI 302, AISI 316L

P.109



**ZPQ CAM & LEVER CLAMPS**

- Thread size: 1 1/4", 1 1/2"
- Body: Fiberglass reinforced PP
- O-ring: NBR
- Pins: AISI 316

P.106



**ZSA QUICK COUPLING JOINTS**

- Thread size: 3/4" ~ 1 1/2"
- Materials: AISI 316, Fiberglass reinforced PP

P.114

# SWIVEL JOINTS



**ZRA STANDARD SWIVEL JOINTS**

- Thread size: 1/8" ~ 3/4"
- Materials: AISI303, AISI 316L, Brass

P.115



**ZRP TRIANGLE FLANGED SWIVEL JOINTS**

- Thread size: 1/8" ~ 3/8"
- Materials: AISI303, AISI 316L, Brass

P.116



**ZRQ LARGE CAPACITY SWIVEL JOINTS**

- Thread size: 1" ~ 2-1/2"
- Materials: AISI303, AISI 316L, Brass

P.116



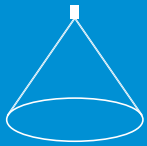

# SPRAY TECHNOLOGY

## THE PROCESS OF ATOMIZATION

A liquid spraying process can be described as consisting of two phases, namely:

1. breaking of the liquid into separate droplets
2. directing the liquid drops onto a surface or an object, to achieve the desired result.

Modern technology allows for a strict control of different parameters of a liquid spray; for example precise information can be obtained about droplet size spectrum, droplets speed and liquid distribution onto the spray target. In recent years we've supported our customers in improving their productivity and market share by providing them cutting edge industrial techniques. *PNR is your best partner to help you enhance your productivity and quality.*

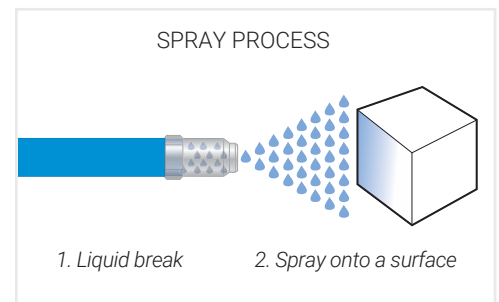

## APPLICATIONS

Spraying a liquid through a spray nozzle can serve different purposes:

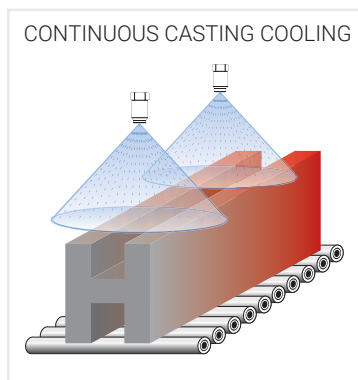

**COOLING**  
Heat transfer by spraying liquids onto the products surface for a rapid cooling, such as continuous casting cooling in steelworks.

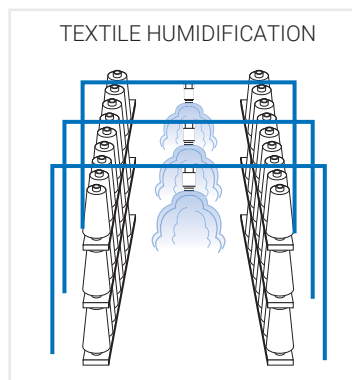

**HUMIDIFICATION**  
Spray of very little quantities of liquid onto the products surface into special chambers or rooms to raise relative humidity. A typical application is textiles humidification.

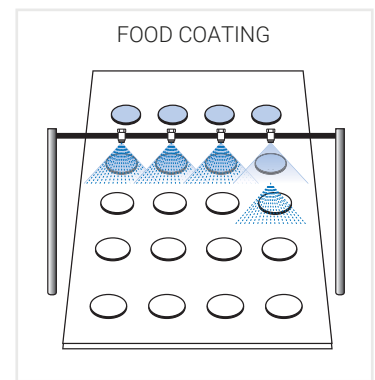

**COATING**  
Application of coatings or liquids on the food products surface. For example: oil-spraying on bread.

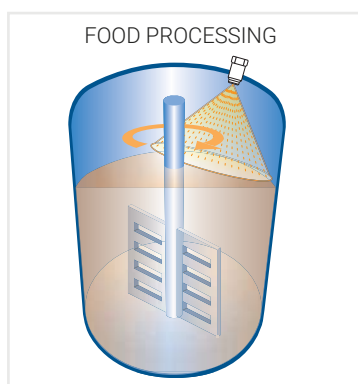

**FOOD PROCESSING**  
Spray to add specific ingredients or substances to speed up chemical reactions. For ex.: addition of fructose in fruit juices, etc.

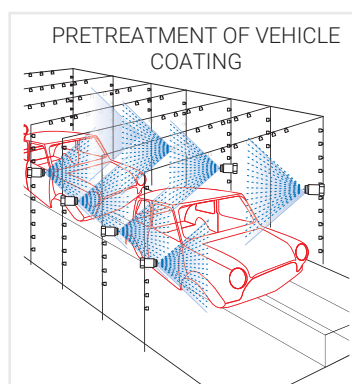

**WASHING**  
Remove dirt from the product surface spraying liquids at high pressure, like in vehicles pre-wash treatment.

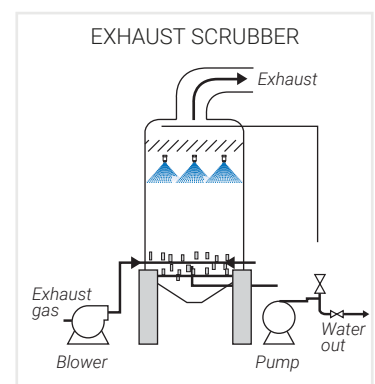

**POLLUTION CONTROL**  
Use of atomized scrubbing liquids to capture particulate matter and/or gaseous pollutants in liquid droplets, like in web scrubbers and spray towers.

## SPRAY NOZZLES TECHNICAL FEATURES

Several technical features must be taken into account to select the proper nozzle.

### 1. NOZZLE EFFICIENCY

A spray nozzle is a device that turns the pressure energy of a liquid flow into kinetic energy. The nozzle efficiency can be defined as the ratio between the energy available at the nozzle inlet and the energy which is actually used to increase the liquid speed and create the spray, the difference being the energy lost during the process because of friction. Depending on the nozzle type and for a good quality machining, the nozzle efficiency varies between 55% and 95% for the types that are commonly used in industrial processes. What is above stated is not valid for air-assisted atomizers which require a much higher energy because of the losses inherent in the energy transfer from compressed air to liquid surface.

### 2. DROPLETS SIZE

The droplets size depends on the structure of the atomizer, intensity of the liquids energy, liquid surface tension and density. The size of the atomized droplets is not uniform. Therefore, the average droplets size becomes an important factor. For example, the droplets size in gas quenching towers is extremely important. If their size is too big, they do not fully evaporate leading to dust bag failure. On the contrary, if the droplets size is too small, it's not possible to lower the temperature to the desired level and high temperature may cause the dust bags burn out.

There are four ways to express the droplets size:

The Sauter Mean Diameter (SMD) is the most commonly used. It refers to the drop volume/surface area ratio and it's often shown as D32,  $\mu\text{m}$ (Micron) unit. ( $1\mu\text{m}=10^{-3}\text{mm}$ )

- ARITHMETIC MEAN DIAMETER

This is a diameter value which, multiplied by the local number of droplets in the sample, equals the addition of all droplets diameters.

- SURFACE MEAN DIAMETER

This is a diameter of such a droplet whose surface, multiplied by the total droplets number, equals the sum of all droplets surfaces.

- VOLUME MEAN DIAMETER

This is the diameter of such a droplet whose volume, multiplied by the total droplets number, equals the sum of all droplets volumes.

- SAUTER MEAN DIAMETER (D32)

This is the diameter of such a droplet whose volume/area ratio, equals the ratio between the sum of all droplet volumes divided by the sum of all droplet surfaces.



#### MEASUREMENT METHODS

SMD is tested using pure water at 30°C

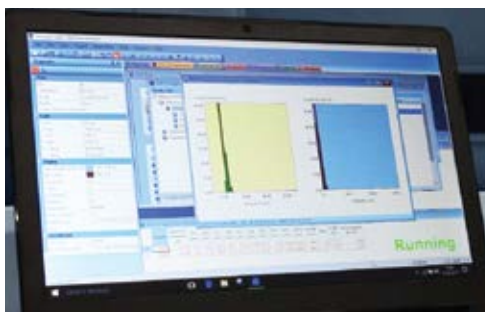

#### LASER INTERFEROMETER TEST

As different droplets have different PI, they produce different refraction angles. Therefore laser light can be used to measure their size. This type of method is fast and precise.

*PNR can perform this test with technologically advanced equipments and provide complete documentation containing test reports. Please contact us for more information.*

## SPRAY NOZZLES TECHNICAL FEATURES

### 3. SPRAY ANGLE

A spray angle is the angle formed by the cone of liquid leaving a nozzle orifice.

The spray angle and the distance between the nozzle orifice and the target surface to be covered determine the spray coverage.

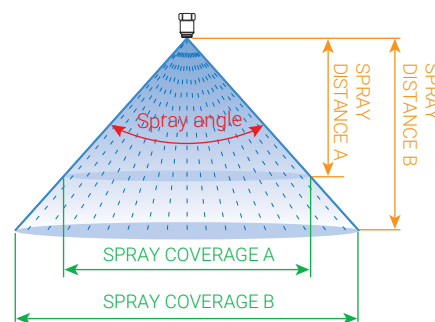

### 4. IMPACT FORCE

The impact force is the force generated by the jet of water deflected by the impact surface and its strength is often expressed in kg/cm<sup>2</sup> or lb/inch<sup>2</sup>. The uniformity of a jet impact force and distribution influence the washing effect. Under the same operating conditions (same pressure and capacity), different types of nozzles can be used to perform an impact force test and the results are shown here below.

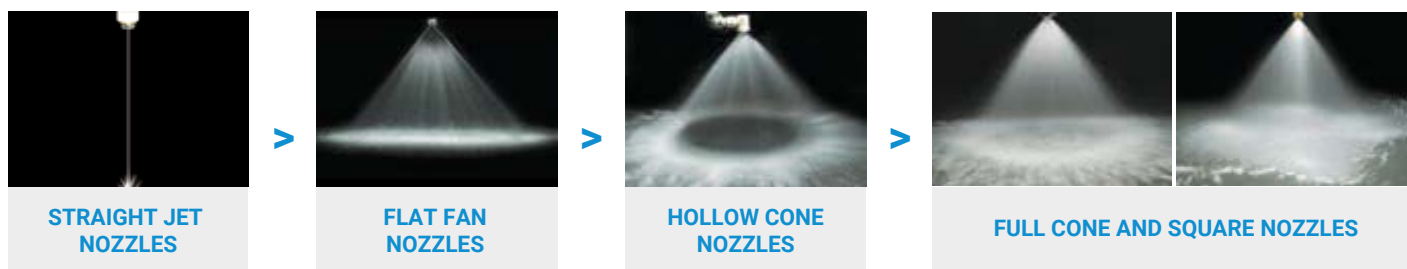

### 5. DISTRIBUTION

Engineers design nozzles with different spray distribution patterns. Patterns can be solid stream, full cone, hollow cone, flat spray, spoon flat fan. The nozzle design aims at the uniformity and impact force of the jet sprayed whether nozzles are used individually or overlapping. Below figures show detailed information for a variety of capacities and spray sections. We mark distribution on every page for your convenience.

<b>FLAT FAN</b> Convex distribution	<b>FLAT FAN</b> Even distribution	<b>FULL CONE</b> Convex distribution	<b>FULL CONE</b> Even distribution	<b>HOLLOW CONE</b> Concave distribution	<b>STRAIGHT JET</b> Single-point distribution



## TECHNIQUES FOR SPRAY PRODUCTION

Many different hydrodynamics techniques can be used to produce a spray and most of them are used today for nozzles to be applied in industrial processes.

### PRESSURE NOZZLES

This is the simplest type of nozzle where an orifice is opened into a chamber where the liquid to be sprayed is fed under pressure. A spray is produced through the orifice with spray pattern, flow rate and spray angle depending upon the orifice edge profile and the design of the inside pressure chamber. Typical pressure nozzles are J series straight nozzles and F series high pressure flat fan nozzles.



### TURBOLENCE NOZZLES

Turbulence nozzles use specially shaped vanes which force the pressurized liquid into a whirl chamber producing its high-speed rotation. This breaks up the liquid which exists the nozzle orifice atomized at high-speed. Different nozzle structures and flow rates produce hollow cone, full cone and full square cone spray patterns. Typical turbulence nozzles are RA series hollow cone and D series full cone nozzles.



### IMPACT NOZZLES

Here the desired spray shape is obtained producing an impact of the liquid jet onto a properly designed surface. The liquid jet is subsequently changed into a fluid lamina and then broken into drops with the desired spray pattern after leaving the nozzle edge. Typical impact nozzles are K series flat fan nozzles, E series spiral full cone nozzles and RC series hollow cone nozzles.

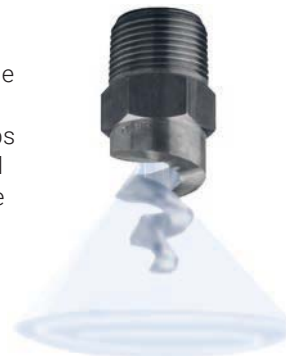

### AIR ASSISTED NOZZLES

Depending on the liquid supply, these nozzles are of two types: *Pressure nozzles and Siphon nozzles.*

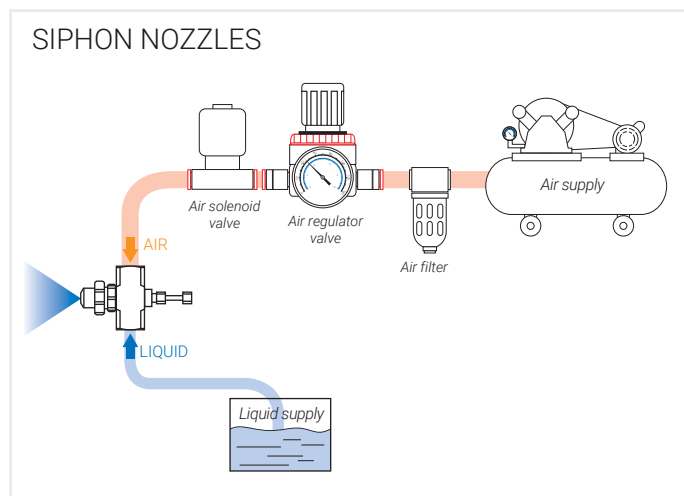
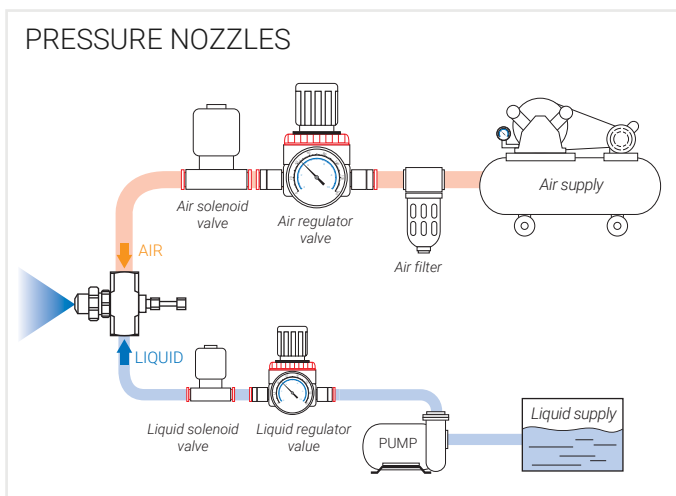

## TECHNIQUES FOR SPRAY PRODUCTION

**AIR-ASSISTED ATOMIZERS:** they use their special design and pressurized gas to atomize a liquid and break it into tiny droplets (the smallest average particle size: 10 micron).



**ULTRASONIC ATOMIZERS:** they are sister products of air-assisted atomizers. The front-end has a titanium ultrasonic generator. It uses the energy of the high-speed impact to produce a high-frequency oscillation that micro-atomizes the liquid droplets. The special design produces tiny and uniform droplets (the average smallest particle size: 7 Micron). The advantages are vital to many applications. Ultrasonic atomizers have two phases of atomization. Phase one: liquids mix with pressured air and produce tiny droplets to spray. Phase two: when the atomized droplets hit the ultrasonic generator they get micro-atomized generating smaller droplets.

Please refer to the *Atomizer Catalogue* which you can download on our website [www.pnr.eu](http://www.pnr.eu).



## QUALITY CHECK

Although nozzles are used to atomize liquids, the atomization precision and effect are deeply influenced by their quality. With our expertise we fully understand our customers needs and expectations and our engineers set high quality control standards not only for the operating precision of our nozzles but also for product inspection. PNR ensures the best atomizing effects and provides capacity and spray angle accuracy with a tolerance of  $\pm 10\%$  guarantee.

<p><b>1 CHECK IF LIQUID FLOW AND PRESSURE ARE IN DIRECT PROPORTION</b></p>	<p><b>2 CHECK IF SPRAY ANGLE IS AS REQUIRED</b></p>	
<p><b>3 CHECK IF CAPACITY IS AS REQUIRED</b></p>	<p><b>4 CHECK IF DISTRIBUTION IS UNIFORM</b></p>	<p><b>5 CHECK IF DROPLETS DIAMETER IS UNIFORM</b></p>

# SPRAY PATTERN

## FULL CONE PATTERN

The shape of the tip determines the spray range of *full cone nozzles*. A typical application of these nozzles is continuous casting cooling when it's necessary to spray the same volume of liquids onto a surface to cool objects. Our engineers design a series of full cone nozzles to satisfy different needs. No matter what kind of full cone nozzles they are, they have unique applications.

### STANDARD FULL CONE (Turbulence nozzle)

These nozzles use a specially shaped vane placed at the nozzle inlet to give a rotational speed to the fluid flowing through the nozzle. Because of the rotational speed of the fluid, water exiting the nozzle orifice is subjected to centrifugal force and opens up in the shape of a full cone.

The extent of the angle of the cone is a function of both exit speed (created from the inlet pressure) and the internal design of the nozzle. It can vary in practice from 15° to 120°.

These nozzles can be also produced as square full cone nozzles where the square shape of the pyramidal spray is obtained by a special design of the outlet orifice.

Two important details have to be noted from the system designer when using these type of nozzles:

1. The spray angle is measured on the side of the square section.
2. The square section of the spray rotates within the distance from the nozzle orifice to the target area.



### SPIRAL FULL CONE (Impact nozzle)

This is not properly a full cone but rather a continuous liquid curtain evolving with the shape of a spiral inside a conical volume. The disadvantage of a scarcely even distribution is compensated by an exceptionally good resistance to clogging, large orifice and vaneless which make this nozzle the best choice in those applications such as wet scrubber, fire-fighting systems, etc.



### MULTIPLE FULL CONE (Turbulence nozzle)

Several nozzles are grouped in a cluster with different spray directions.

These nozzles produce large capacity of watermist.

If you need both large capacity and mist, multi-orifice full cone nozzles are the best option.



## FLAT FAN SPRAY PATTERN

A flat fan spray nozzle serves the purpose of spraying onto a surface or an object moving in a transverse direction with respect to the one of the jet surface, a typical example being the nozzles in a car washing tunnel. The vast majority of flat spray nozzles used in the industry work according to one of the following principles.

### IN LINE FLAT FAN (Pressure nozzle)

This is the general purpose flat fan nozzle where the liquid enters the nozzle in line with the axis length and is fed to a pressure chamber from where it is ejected through the nozzle orifice. Flow value and spray angle are determined respectively from the orifice cross section and the orifice edge profile.

### IN LINE STRAIGHT JET (Pressure nozzle)

Straight nozzles can be considered as flat fan nozzles as the only difference is the spray angle which is zero degrees in straight nozzles. These nozzles are often used in high-pressure operating environments where the wear resistance of the nozzles is very important. It ensures optimum service life and spray orientation. PNR offers a wide range of material selection.

- 416 hardened stainless steel
- Ruby nozzle + stainless steel body
- Tungsten carbide nozzle tip + stainless steel body

### SPOON FLAT FAN (Impact nozzle)

These nozzles feature a flat fan spray. According to the different arc design, these spoon flat fan nozzles can be of two types: high impact with narrow spray angle or low pressure with wide spray angle.

- Under the same operating conditions, narrow angle high impact nozzles produce a higher impact force than standard flat fan nozzles. They are suitable for cleaning environments that need strong impact force.
- Low pressure nozzles with wider spray angle produce a 130° spray angle and a large area of water curtain effect. Low-impact spray nozzles are widely used in various applications such as foam removal, water curtain for gas separation, fruits and vegetables cleaning.



High impact types



Large spray angle

## HOLLOW CONE SPRAY PATTERN

A hollow cone spray pattern is made of droplets concentrated on a ring-shaped impact area, with no droplets falling inside the conic volume. Under the same operating conditions, hollow cone nozzles produce a very fine atomized liquid mist and can capture a higher rate of suspended particles than other nozzles. They are widely used in exhaust scrubbers and gas cooling.

### HOLLOW CONE (Turbulence nozzle)

These nozzles use a tangential injection of liquid into a whirling chamber to generate centrifugal forces which break up the liquid vein as soon as it leaves the orifice. Precisely designed orifice profiles, making use of the Coanda effect, provide the ability to obtain very large spray angles.

### HOLLOW CONE (Deflection nozzle)

A hollow cone can also be obtained taking a liquid flow to change direction onto a properly designed surface in order to break the liquid into droplets and distributes them as a hollow cone spray pattern with clog resistance. This kind of nozzle is mainly used for applications in fire-fighting systems.



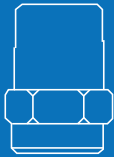

# FULL CONE NOZZLES

There are two types of full cone nozzles: *turbulence nozzles* and *impact nozzles*, distinguishable by their different spray patterns.

## TURBULENCE NOZZLES

They use vanes to produce a high-speed rotation and pressurize the liquid flow inside a turbulence chamber. Liquids are atomized by the centrifugal force that produces a solid stream jet with a full cone spray pattern.

## IMPACT NOZZLES

They work on the impact principle. Liquids hit their spiral profile, atomize and produce large spray flows with full-cone patterns and desired spray angle. They have no vanes and are virtually clog-free.

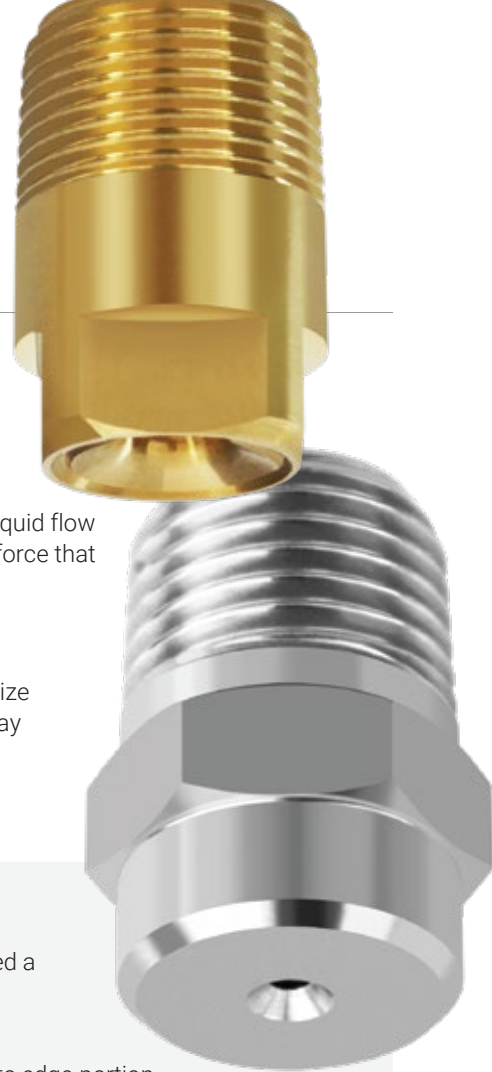

## VANES

To meet the needs of different operating environments, PNR developed a series of vanes, each one with its own technical features.



**SLOTTED VANE**

**SLOTTED VANE.** So called for its spray section with 6 flows slots on its edge portion and one in the center. These vanes produce high-speed rotation of pressurized liquids that flow into turbulence chambers where they are atomized. Slotted vanes provide an excellent atomization in a short time. Effective for cost-saving and in case of limited space.



**DISC VANE**

**DISC VANE.** Innovative design and precise machining, its smooth surface reduces pressure loss and avoids turbulence. It uses 6 peripheral passages to create a swirling motion of the liquid inside the spray chamber. A set of superficial millings on the lower side of the disc act as a brake on the liquid rotation at the centre creating a full cone jet with an even distribution and finely atomized droplets. No central hole to avoid clogging.



**FULL CONE**  
Round spray

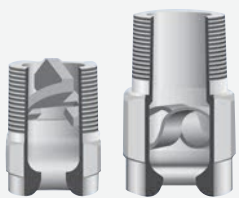

**X-VANE S-TYPE VANE**

**X-VANES.** They are widely used, mainly in steelworks. Their simple design is based on two sloping flat surfaces which induce a rotation of the liquid going through the nozzle, and two small slots on each flat part to produce a full-cone spray pattern. All vanes are secured inside the nozzle body to prevent their moving in case of size changes due to high temperatures or sudden vacuum conditions in the feed pipe.

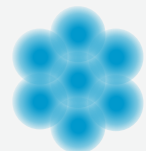

**FULL CONE**  
Cluster spray



**SPIRAL VANE**

**S-TYPE VANES.** They provide a large free passage of liquids through the nozzle, with nearly the same diameter of a spray tip. Therefore they offer the widest possible passage and the highest resistance to clogging among all full-cone spray nozzles with internal vane.

**SPIRAL VANE.** It is specific design of spiral full cone nozzles. Liquids hit spiral vane then atomize and extend to the desired spray angle. The specific design greatly increases liquids inlet and outlet diameter. Any foreign matters entering could come out. It avoids clogging and provides larger capacity with the same thread size.



**FULL CONE**  
Round spray



## ACCURATE SPRAYS OVERLAPPING

When full and hollow cone nozzles are used simultaneously, it's vital that they cover a uniform spray volume. In general there are two methods to achieve accurate nozzles settings: *matrix configuration* and *offset configuration*.

### MATRIX CONFIGURATION

- O** - width of overlapping area (OVERLAP)
- D** - diameter of spray range
- H** - nozzle distance to the object being sprayed
- P** - nozzle spacing
- θ** - spray angle

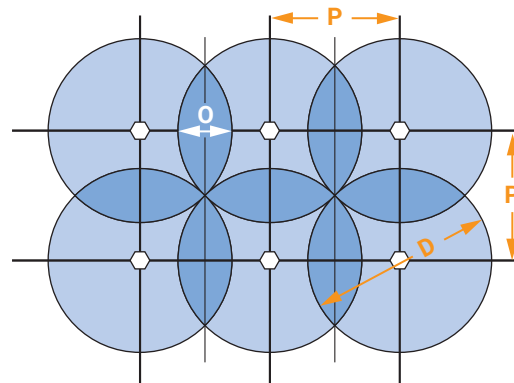
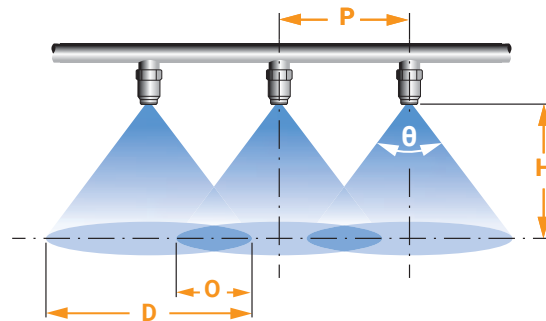

#### NOZZLE SPACING

$$P = \frac{D}{\sqrt{2}}$$

#### OVERLAP

$$O = D - P$$

### OFFSET CONFIGURATION

- O** - width of overlapping area (OVERLAP)
- D** - diameter of spray range
- H** - nozzle distance to the object being sprayed
- P** - nozzle spacing
- θ** - spray angle

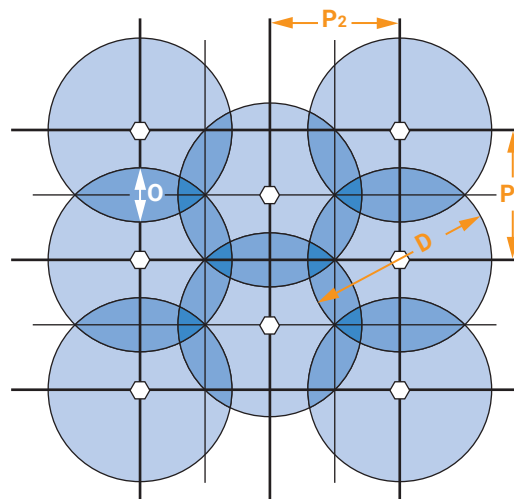
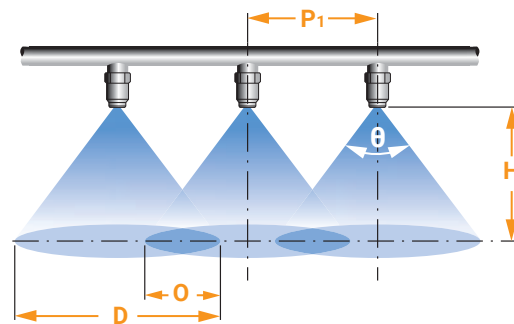

#### NOZZLE SPACING

$$P_1 = \frac{D}{2} \times \sqrt{3}$$

$$P_2 = \frac{3}{4} D$$

#### OVERLAP

$$O = D - P_1$$

# AA ( FULL CONE NOZZLES / SHORT BODY )

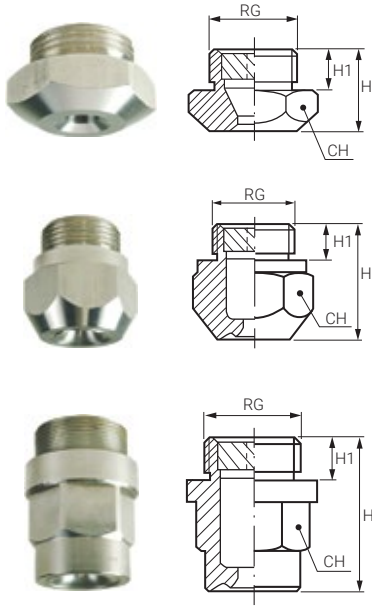

## SLOTTED VANE

AA series full cone nozzles are made of body and slotted vane, for an even spray distribution. Their design allows them to be 35% shorter than other full cone nozzles. They are used in operating environments with a restricted space available and are cost-effective for the lower material quantity.

## THREAD SIZE

BSP, NPT (optional)

## TYPICAL APPLICATIONS

*Washing:* exhaust scrubbers washing, vehicle parts and gravel washing

*Cooling:* high-temperature cooling, vehicle parts cooling, tank cooling

*Other applications:* spray of chemicals, sea water desalination

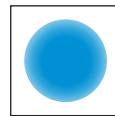

Spray section

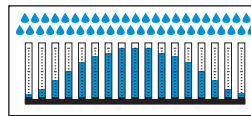

Convex distribution



ANGLE	CODE	RG inch	D mm	D1 mm	Capacity at different pressure values (l/min) (bar)								H mm	H1 mm	WS mm
					0.5	0.7	1.0	2.0	3.0	5.0	7.0	10			
90°	<b>AAU 2305 xx</b>	3/4"	6.1	3.0	12.5	14.7	17.6	24.9	30.5	39.4	46.6	55.7	22	10	32
	<b>AAU 2385 xx</b>		6.7	3.0	15.7	18.6	22.2	31.4	38.5	49.7	58.8	70.3			
	<b>AAU 2490 xx</b>		7.8	4.0	20.0	23.7	28.3	40.0	49.0	63.3	74.8	89.5			
	<b>AAU 2610 xx</b>	1"	9.0	4.0	24.9	29.5	35.2	49.8	61.0	78.7	93.2	111	27	12	40
	<b>AAU 2780 xx</b>		10.5	5.0	31.8	37.7	45.0	63.7	78.0	101	119	142			
	<b>AAU 3123 xx</b>	1 1/4"	12.5	6.0	50.2	59.4	71.0	100	123	159	188	225	30	14	50
	<b>AAU 3194 xx</b>	1 1/2"	16.0	6.0	79.2	93.7	112	158	194	250	296	354	35	16	60
	<b>AAU 3310 xx</b>	2"	20.0	7.0	127	150	179	253	310	400	474	566	45	18	75
	<b>AAU 3386 xx</b>		23.0	9.0	158	186	223	315	386	498	590	705			
	<b>AAU 3490 xx</b>	2 1/2"	25.0	12.0	200	237	283	400	490	633	748	895	52	22	90
<b>AAU 3610 xx</b>	28.5		13.0	249	295	352	498	610	788	932	1114				
<b>AAU 3775 xx</b>	3"	32.0	16.0	316	374	447	633	775	1001	1184	1415	60	24	110	
120°	<b>AAW 2490 xx</b>	3/4"	7.9	3.0	20.0	23.7	28.3	40.0	49.0	63.3	74.8	89.5	38	11	32
	<b>AAW 2780 xx</b>	1"	13.7	6.0	31.8	37.7	45.0	63.7	78.0	101	119	142	47	15	40
	<b>AAW 3123 xx</b>	1 1/4"	12.7	6.0	50.2	59.4	71.0	100	123	159	188	225	62	19	50
	<b>AAW 3194 xx</b>	1 1/2"	16.0	6.0	79.2	93.7	112	158	194	250	296	354	77	21	50
	<b>AAW 3310 xx</b>	2"	20.0	10.0	127	150	179	253	310	400	474	566	99	24	60
	<b>AAW 3386 xx</b>		22.7	10.0	158	186	223	315	386	498	590	705			
	<b>AAW 3490 xx</b>	2 1/2"	25.5	12.0	200	237	283	400	490	633	748	895	123	27	75
	<b>AAW 3610 xx</b>		30.0	13.0	249	295	352	498	610	788	932	1114			
	<b>AAW 3775 xx</b>	3"	32.0	14.0	316	374	447	633	775	1001	1184	1415	150	30	85



Slotted disc vane



AA nozzles design is ideally suited for plastic materials.

Slotted vane, so called for its spray section with 6 flows slots on its edge portion and one in the centre. These vanes produce high-speed rotation of pressurized liquids that flow into turbulence chambers where they are atomized. Slotted vanes provide an excellent atomization in a short time. Effective for cost-saving and in case of limited space.

MATERIAL	3/4"	1"	1 1/4"	1 1/2"	2"	2 1/2"	3"
<b>B31</b> - AISI 316L					•	•	•
<b>T1</b> - Brass	•						
<b>D1</b> - PVC	•	•	•	•	•	•	•

### HOW TO MAKE UP THE NOZZLE CODE

Ex.: AAU 2305 B31

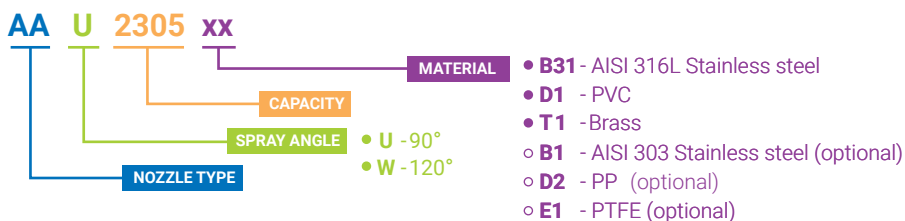

( FULL CONE NOZZLES / FLANGE ) **AE**

SLOTTED VANE

AE type nozzles are designed to deliver large and very large capacity values from 384 l/min to 3842 l/min at 0.5 bar. The carefully designed slotted vane offers uniform spray distribution and perfect performance even with very low inlet pressure values. Compared to other large nozzles, the upper flange reduces the length of nozzles and offers fast and safe ways to install.

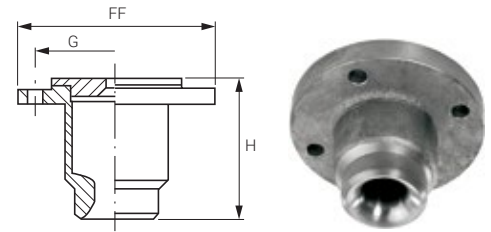

FLANGE SPECIFICATION  
UNI / DIN / ASA Standard  
JIS Standard (optional)

TYPICAL APPLICATIONS

- Cooling:** Coke quench tower scrubber system  
Exhaust gas cooling
- Cleaning:** High-temperature cooling  
Desulfuration  
Exhaust scrubbers

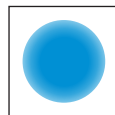

Spray section

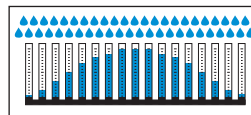

Convex distribution

90°	CODE	DN mm	D mm	D1 mm	Capacity at different pressure values (l/min) (bar)								FF mm	G mm	H mm
					0.25	0.35	0.5	0.7	1.0	2.0	3.0	5.0			
90°	<b>AEU 3940 xx</b>	80	37.0	12.0	271	321	384	454	543	768	940	1214	200	160	140
	<b>AEU 4118 xx</b>		39.0	14.0	341	403	482	570	681	963	1180	1523			
	<b>AEU 4147 xx</b>	100	43.0	13.0	424	502	600	710	849	1200	1470	1898	220	180	156
	<b>AEU 4188 xx</b>	125	53.0	16.0	543	642	768	908	1085	1535	1880	2427	250	210	177
	<b>AEU 4235 xx</b>		56.0	16.0	678	803	959	1135	1357	1919	2350	3034			
	<b>AEU 4294 xx</b>	150	59.0	21.0	849	1004	1200	1420	1697	2400	2940	3796	285	240	188
	<b>AEU 4370 xx</b>		66.0	24.0	1068	1264	1511	1787	2136	3021	3700	4777			
	<b>AEU 4470 xx</b>	200	72.0	28.0	1357	1605	1919	2270	2714	3838	4700	6068	340	295	250
	<b>AEU 4588 xx</b>		81.0	32.0	1697	2008	2400	2840	3395	4801	5880	7591			
<b>AEU 4741 xx</b>	250	88.0	39.0	2139	2531	3025	3579	4278	6050	7410	9566	395	350	291	
<b>AEU 4941 xx</b>		99.0	37.0	2716	3214	3842	4545	5433	7683	9410	12148				
120°	<b>AEW 3940 xx</b>	80	36.0	15.0	271	321	384	454	543	768	940	1214	200	160	140
	<b>AEW 4118 xx</b>		40.5	14.5	341	403	482	570	681	963	1180	1523			
	<b>AEW 4147 xx</b>	100	43.0	18.5	424	502	600	710	849	1200	1470	1898	220	180	156
	<b>AEW 4188 xx</b>	125	53.0	22.0	543	642	768	908	1085	1535	1880	2427	250	210	177
	<b>AEW 4235 xx</b>		55.0	24.0	678	803	959	1135	1357	1919	2350	3034			
	<b>AEW 4294 xx</b>	150	59.0	28.0	849	1004	1200	1420	1697	2400	2940	3796	285	240	188
	<b>AEW 4370 xx</b>		66.0	32.0	1068	1264	1511	1787	2136	3021	3700	4777			
	<b>AEW 4470 xx</b>	200	75.0	35.0	1357	1605	1919	2270	2714	3838	4700	6068	340	295	250
	<b>AEW 4588 xx</b>		81.0	40.0	1697	2008	2400	2840	3395	4801	5880	7591			
<b>AEW 4741 xx</b>	250	86.0	37.0	2139	2531	3025	3579	4278	6050	7410	9566	395	350	291	
<b>AEW 4941 xx</b>		96.0	42.0	2716	3214	3842	4545	5433	7683	9410	12148				

HOW TO MAKE UP THE NOZZLE CODE

Ex.: AEU 3940 A1

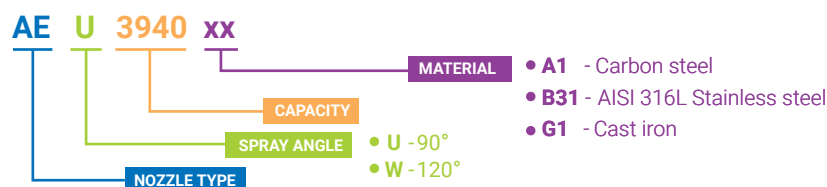

# AH ( FULL CONE NOZZLES / FINE MIST )

## IN-LINE FULL CONE

AH series nozzles are made of a body and a disc vane and provide a very uniform spray distribution onto the entire coverage area. AH nozzles have been widely used in continuous casting plants for many years. The special design of their vane produces a fine atomization of the liquid and highly improves its distribution.

These innovative nozzles, highly appreciated for their performance, are widely used in the steelworks industry both in Europe and America.

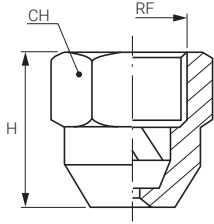

THREAD SPECIFICATION: BSP, NPT

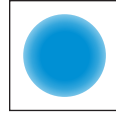

Spray section

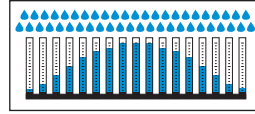

Convex distribution



### DISC VANE

This innovative vane is machined with high precision. Its smooth surface reduces pressure loss and avoids turbulence. Its stabilizer acts as a hydrodynamic brake on the fluid rotating at high-speed inside the whirl chamber. Its shape splits the liquid leaving the nozzle into 6 flows. Disc vanes produce micro-droplets and even atomization.

Spray Angle	CODE	RF inch	D mm	Capacity at different pressure values (l/min) (bar)					H mm	WS mm
				1.0	2.0	3.0	4.0	5.0		
65°	<b>AHR 1309 xx</b>	1/4"	1.9	1.78	2.52	3.09	3.57	3.99	25.0	19
	<b>AHR 1362 xx</b>		2.0	2.09	2.96	3.62	4.18	4.67		
	<b>AHR 1409 xx</b>		2.2	2.36	3.34	4.09	4.72	5.28		
	<b>AHR 1517 xx</b>		2.6	2.98	4.22	5.17	5.97	6.67		
	<b>AHR 1207 xx</b>	3/8"	1.0	1.20	1.69	2.07	2.39	2.67	26.5	22
	<b>AHR 1258 xx</b>		1.0	1.49	2.11	2.58	2.98	3.33		
	<b>AHR 1310 xx</b>		1.9	1.79	2.53	3.10	3.58	4.00		
	<b>AHR 1340 xx</b>		2.0	1.96	2.78	3.40	3.93	4.39		
	<b>AHR 1363 xx</b>		2.1	2.10	2.96	3.63	4.19	4.69		
	<b>AHR 1415 xx</b>		2.2	2.40	3.39	4.15	4.79	5.36		
	<b>AHR 1470 xx</b>		2.5	2.71	3.84	4.70	5.43	6.07		
	<b>AHR 1518 xx</b>		2.6	2.99	4.23	5.18	5.98	6.69		
	<b>AHR 1621 xx</b>		2.7	3.59	5.07	6.21	7.17	8.02		
	<b>AHR 1780 xx</b>		2.9	4.50	6.37	7.80	9.01	10.1		
	<b>AHR 1828 xx</b>		3.1	4.78	6.76	8.28	9.56	10.7		
<b>AHR 1873 xx</b>	3.3	5.04	7.13	8.73	10.1	11.3				
<b>AHR 2110 xx</b>	1/2"	4.2	6.35	8.98	11.0	12.7	14.2	36.0	27	
<b>AHR 2144 xx</b>		4.2	8.31	11.8	14.4	16.6	18.6			
<b>AHR 2154 xx</b>		5.0	8.89	12.6	15.4	17.8	19.9			
80°	<b>AHT 1309 xx</b>	1/4"	2.2	1.78	2.52	3.09	3.57	3.99	25.0	19
	<b>AHT 1362 xx</b>		2.2	2.09	2.96	3.62	4.18	4.67		
	<b>AHT 1409 xx</b>		2.2	2.36	3.34	4.09	4.72	5.28		
	<b>AHT 1517 xx</b>		2.6	2.98	4.22	5.17	5.97	6.67		
	<b>AHT 1258 xx</b>	3/8"	2.0	1.49	2.11	2.58	2.98	3.33	26.5	22
	<b>AHT 1310 xx</b>		2.0	1.79	2.53	3.10	3.58	4.00		
	<b>AHT 1340 xx</b>		2.0	1.96	2.78	3.40	3.93	4.39		
	<b>AHT 1363 xx</b>		2.1	2.10	2.96	3.63	4.19	4.69		
	<b>AHT 1415 xx</b>		2.2	2.40	3.39	4.15	4.79	5.36		
	<b>AHT 1518 xx</b>		2.6	2.99	4.23	5.18	5.98	6.69		
	<b>AHT 1621 xx</b>		2.7	3.59	5.07	6.21	7.17	8.02		
	<b>AHT 1780 xx</b>		2.9	4.50	6.37	7.80	9.01	10.1		
	<b>AHT 1828 xx</b>		3.1	4.78	6.76	8.28	9.56	10.7		
	<b>AHT 1873 xx</b>		3.1	5.04	7.13	8.73	10.1	11.3		
	<b>AHT 2110 xx</b>		1/2"	4.2	6.35	8.98	11.0	12.7		
<b>AHT 2144 xx</b>	4.2	8.31		11.8	14.4	16.6	18.6			
45°	<b>AH (FULL CONE NOZZLES / FINE MIST) SPRAY ANGLE 45°</b>									

### HOW TO MAKE UP THE NOZZLE CODE

Ex.: AHR 1390 B1

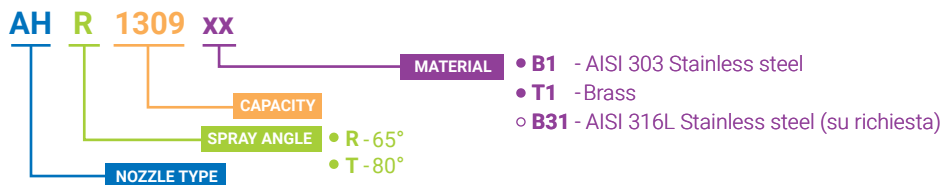

( FULL CONE NOZZLES / NON CLOGGING ) **AL**

S-TYPE VANE

AL nozzles offer distinctive advantages due to their special construction, with an integrated S-shaped vane cast in one piece with the nozzle body with an investment casting process. The special design S-shaped vane offers the largest free passage available in a full cone nozzle (actually identical to the nozzle orifice diameter) and can easily handle dirty or recirculated liquids as well as suspended particles to avoid clogging. The best reliability is then assured under the most difficult conditions, which makes these nozzles the right choice in those plants with nozzle clogging problems or where removing and cleaning a clogged nozzle is a difficult job.

THREAD SPECIFICATION: BSPT, NPT

CAPACITY FOR NOZZLES MADE IN PVDF, PP

ALS 70°	ALU 90°	CODE	RG inch	D mm	Capacity at different pressure values (l/min) (bar)							
					0.2	0.3	0.5	0.7	1.0	2.0	3.0	5.0
•	•	<b>2190 xx</b>	3/8"	3.97	5.32	6.46	8.17	9.50	11.4	15.8	19.0	24.1
•	•	<b>2250 xx</b>		4.76	7.00	8.50	10.8	12.5	15.0	20.8	25.0	31.8
	•	<b>2350 xx</b>	1/2"	5.56	9.80	11.9	15.1	17.5	21.0	29.1	35.0	44.5

CAPACITY FOR NOZZLES MADE IN AISI 316L

ALQ 60°	ALU 90°	ALW 120°	CODE	RG inch	D mm	Capacity at different pressure values (l/min) (bar)							
						0.2	0.3	0.5	0.7	1.0	2.0	3.0	5.0
•	•	•	<b>1927 xx</b>	3/8"	3.18	2.60	3.14	3.99	4.68	5.53	7.66	9.27	11.8
•	•	•	<b>2147 xx</b>		3.97	4.13	4.99	6.35	7.43	8.79	12.2	14.7	18.7
•	•	•	<b>2213 xx</b>		4.76	5.96	7.21	9.17	10.7	12.7	17.6	21.3	27.1
•	•	•	<b>2214 xx</b>	1/2"	4.76	5.96	7.21	9.17	10.7	12.7	17.6	21.3	27.1
•	•	•	<b>2339 xx</b>		5.56	9.48	11.5	14.6	17.1	20.2	28.0	33.9	43.0
•	•	•	<b>2380 xx</b>		6.35	10.7	12.9	16.4	19.2	22.7	31.4	38.0	48.4
•	•	•	<b>2468 xx</b>	3/4"	7.14	13.1	15.8	20.1	23.6	27.9	38.6	46.8	59.4
•	•	•	<b>2566 xx</b>		7.94	15.9	19.2	24.4	28.6	33.8	46.8	56.6	72.0
•	•	•	<b>2694 xx</b>		8.73	19.4	23.5	29.9	35.0	41.4	57.3	69.4	88.2
•	•	•	<b>2818 xx</b>		9.53	22.9	27.7	35.2	41.3	48.8	67.6	81.8	104
•	•	•	<b>2819 xx</b>	1"	9.53	22.9	27.7	35.2	41.3	48.8	67.6	81.8	104
•	•	•	<b>2980 xx</b>		10.3	27.5	33.2	42.2	49.2	58.5	81.0	98.0	125
•	•	•	<b>3115 xx</b>		11.1	32.1	38.8	49.4	57.8	68.4	94.7	115	146
•	•	•	<b>3116 xx</b>	1 1/4"	11.1	32.1	38.8	49.4	57.8	68.4	94.7	115	146
•	•	•	<b>3148 xx</b>		12.7	41.3	49.9	63.5	74.3	87.9	122	148	187
•	•	•	<b>3164 xx</b>		13.5	45.8	55.4	70.5	82.5	97.6	135	164	208
•	•	•	<b>3179 xx</b>		14.3	50.2	60.8	77.3	90.5	107	148	179	228
•	•	•	<b>3180 xx</b>	1 1/2"	13.97	50.2	60.8	77.3	90.5	107	148	179	228
•	•	•	<b>3205 xx</b>		15.1	57.3	69.3	88.1	103	122	169	205	260
•	•	•	<b>3218 xx</b>		15.9	61.0	73.8	93.9	110	130	180	218	277
•	•	•	<b>3265 xx</b>		16.7	74.2	89.7	114	134	158	219	265	337
•	•	•	<b>3278 xx</b>		17.5	77.9	94.3	120	140	166	230	278	354
•	•	•	<b>3339 xx</b>	2"	19.1	94.8	115	146	171	202	280	339	430
•	•	•	<b>3370 xx</b>		20.6	104	126	160	187	221	306	370	471
•	•	•	<b>3458 xx</b>		22.2	129	155	197	231	273	378	458	582
•	•	•	<b>3513 xx</b>		23.8	144	174	221	259	306	424	513	652
•	•	•	<b>3600 xx</b>		25.4	168	203	259	303	358	496	600	763
•	•	•	<b>3736 xx</b>		28.6	206	249	317	371	439	608	736	935
•	•	•	<b>3601 xx</b>	2 1/2"	25.4	168	203	259	303	358	496	600	763
•	•	•	<b>3737 xx</b>		28.6	206	249	317	371	439	608	736	935
•	•	•	<b>3883 xx</b>		31.5	247	299	381	446	527	730	883	1120
•	•	•	<b>4106 xx</b>		34.9	297	359	456	535	632	875	1060	1350
•	•	•	<b>4123 xx</b>		38.1	363	440	559	655	774	1070	1230	1650
•	•	•	<b>4124 xx</b>	3"	37.1	363	440	559	655	774	1070	1230	1650
•	•	•	<b>4153 xx</b>		41.3	428	517	658	770	911	1260	1530	1940
•	•	•	<b>4174 xx</b>		44.5	488	591	751	880	1040	1440	1740	2220
•	•	•	<b>4175 xx</b>	4"	44.5	488	591	751	880	1040	1440	1740	2220
•	•	•	<b>4196 xx</b>		47.6	549	664	845	989	1170	1620	1960	2490
•	•	•	<b>4230 xx</b>		49.8	643	778	989	1160	1370	1900	2300	2920
•	•	•	<b>4256 xx</b>		54.0	718	869	1100	1290	1530	2120	2560	3260
•	•	•	<b>4278 xx</b>		57.2	779	943	1200	1400	1660	2300	2780	3540

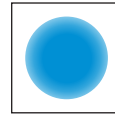

Spray section

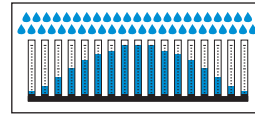

Convex distribution

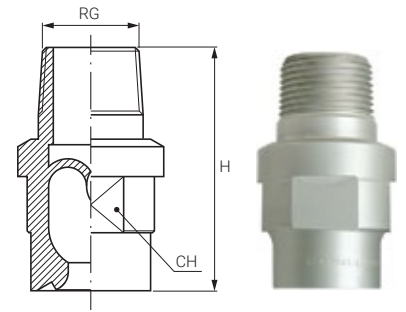

S-TYPE VANE / X-TYPE VANE

S-type vanes provide a large free passage of liquids through the nozzle, with nearly the same diameter of a spray tip. Therefore they offer the widest possible passage and the highest resistance to clogging among all full-cone spray nozzles with internal vane.

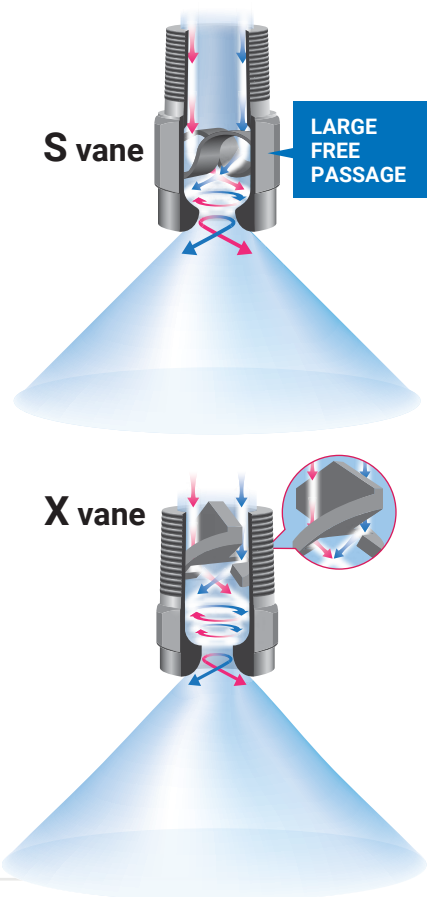

HOW TO MAKE UP THE NOZZLE CODE

Ex.: ALU 1927 B31

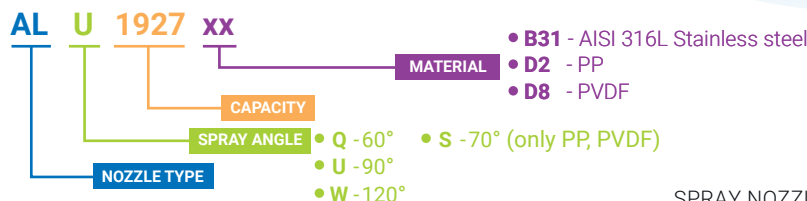



# AT ( FULL CONE NOZZLES / TANGENTIAL )



VANELESS – OFF LINE

AT series nozzles are full cone nozzles producing a high and strong rotation of the liquid. There's no vane inside the whirl chamber which has free internal passages and for this reason these nozzles are less prone to clogging. Moreover, a specially designed tip placed at the bottom of these nozzles increases their atomizing effect. The design of AT nozzles allows a uniform spray distribution and increases their operating life by 20%.

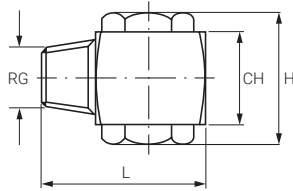

THREAD SPECIFICATION:

BSPT  
NPT (su richiesta)

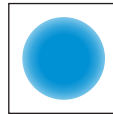

Spray section

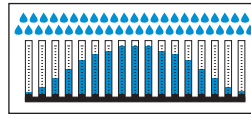

Convex distribution



**TYPICAL APPLICATIONS**

- Washing:*
- Exhaust scrubber
- Parts cleaning
- Pre-treatment for coating process.
- Cooling:*
- Gas cooling
- Tank cooling
- Dust control:*
- Remove dust flying in mining and coal plants.
- Other applications:*
- Spray of chemicals
- Fire engineering

ANGLE	CODE	RG inch	D mm	D1 mm	Capacity at different pressure values (l/min) (bar)							H mm	L mm	WS mm
					1.0	2.0	3.0	4.0	5.0	6.0	7.0			
60°	ATQ 1230 xx	1/8"	2.0	1.8	1.33	1.88	2.30	2.66	2.97	3.25	3.51	22	24	15
	ATQ 1390 xx	1/4"	2.4	2.2	2.25	3.18	3.90	4.50	5.03	5.52	5.96	25	34	20
	ATQ 1490 xx		2.9	2.8	2.83	4.00	4.90	5.66	6.33	6.93	7.48			
	ATQ 1740 xx		3.3	3.2	4.27	6.04	7.40	8.54	9.55	10.5	11.3			
	ATQ 2110 xx	3/8"	5.1	4.6	6.35	8.98	11.0	12.7	14.2	15.6	16.8	27	34	20
90°	ATU 1230 xx	1/8"	2.1	1.8	1.33	1.88	2.30	2.66	2.97	3.25	3.51	22	24	15
	ATU 1390 xx	1/4"	2.5	2.1	2.25	3.18	3.90	4.50	5.03	5.52	5.96	25	34	20
	ATU 1490 xx		3.0	2.1	2.83	4.00	4.90	5.66	6.33	6.93	7.48			
	ATU 1620 xx		3.2	3.0	3.58	5.06	6.20	7.16	8.00	8.77	9.47			
	ATU 1621 xx	3/8"	3.5	3.2	3.58	5.06	6.20	7.16	8.00	8.77	9.47	27	34	20
	ATU 1780 xx		5.0	3.4	4.50	6.37	7.80	9.01	10.1	11.0	11.9			
	ATU 2110 xx		5.1	4.3	6.35	8.98	11.0	12.7	14.2	15.6	16.8			
	ATU 2153 xx		5.3	5.2	8.83	12.5	15.3	17.7	19.8	21.6	23.4			
	ATU 2245 xx	1/2"	8.7	5.5	14.1	20.0	24.5	28.3	31.6	34.6	37.4	38	48	30
	ATU 2315 xx		8.7	6.5	18.2	25.7	31.5	36.4	40.7	44.5	48.1			
	ATU 2385 xx		8.8	7.2	22.2	31.4	38.5	44.5	49.7	54.4	58.8			
	ATU 2530 xx	3/4"	12.6	8.7	30.6	43.3	53.0	61.2	68.4	75.0	81.0	50	58	40
	ATU 2770 xx		12.6	11.2	44.5	62.9	77.0	88.9	99.4	109	118			
	ATU 2420 xx	1"	9.2	9.8	24.2	34.3	42.0	48.5	54.2	59.4	64.2	48	61	42
ATU 2645 xx		10.3	10.3	37.2	52.7	64.5	74.5	83.3	91.2	98.5				
ATU 2870 xx		16.0	11.5	50.2	71.0	87.0	100	112	123	133				
120°	ATW 1310 xx	1/8"	2.5	2.1	1.79	2.53	3.10	3.58	4.00	4.38	4.74	22	24	15
	ATW 1311 xx	1/4"	2.5	2.1	1.79	2.53	3.10	3.58	4.00	4.38	4.74	25	34	20
	ATW 1490 xx		4.1	2.4	2.83	4.00	4.90	5.66	6.33	6.93	7.48			
	ATW 1491 xx	3/8"	4.2	2.7	2.83	4.00	4.90	5.66	6.33	6.93	7.48	27	34	20
	ATW 1621 xx		4.5	3.2	3.58	5.06	6.20	7.16	8.00	8.77	9.47			
	ATW 1780 xx		5.0	3.4	4.50	6.37	7.80	9.01	10.1	11.0	11.9			
	ATW 2110 xx		5.4	4.4	6.35	8.98	11.0	12.7	14.2	15.6	16.8			
	ATW 2245 xx	1/2"	8.5	5.5	14.1	20.0	24.5	28.3	31.6	34.6	37.4	38	48	30
	ATW 2315 xx		8.5	6.3	18.2	25.7	31.5	36.4	40.7	44.5	48.1			
	ATW 2231 xx	3/4"	8.4	5.2	13.3	18.8	23.0	26.6	29.7	32.5	35.1	56	59	40
	ATW 2385 xx		8.8	7.3	22.2	31.4	38.5	44.5	49.7	54.5	58.8			
	ATW 2480 xx		12.6	7.8	27.7	39.2	48.0	55.4	62.0	67.9	73.3			
	ATW 2770 xx		14.0	10.7	44.5	62.9	77.0	88.9	99.4	109	118			
ATW 2420 xx	1"	9.5	8.0	24.2	34.3	42.0	48.5	54.2	59.4	64.2	48	61	42	
ATW 2645 xx		12.8	9.2	37.2	52.7	64.5	74.5	83.3	91.2	98.5	58	61	40	
ATW 2870 xx		16.0	11.5	50.2	71.0	87.0	100	112	123	133	61	68	45	
ATW 3122 xx		18.0	14.0	70.4	99.6	122	141	158	173	186	66	76	50	

**HOW TO MAKE UP THE NOZZLE CODE**

Ex.: ATQ 1230 B1

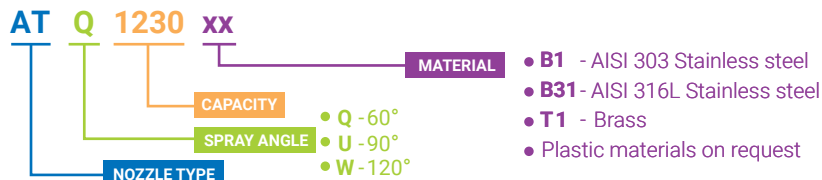

# ( FULL CONE NOZZLES / CLEANABLE ) BA / BC

X-VANE / ROUND SPRAY / THREE PIECES DESIGN / EASY CLEAN

BA/BC series full cone nozzles have a three-piece design made of body, X-vane and nipple. Their X-vane design combines resistance to clogging with the convenience of an easy and fast inside cleaning as they can be easily disassembled for maintenance. When these nozzles are mounted to spray upwards, the design of the nipple avoids losing the vane. BA/BC nozzles are available with a female (BA) or male (BC) inlet thread nipple. See dimensions and weight at the bottom of the page.

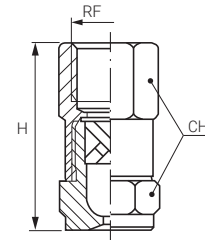

BA

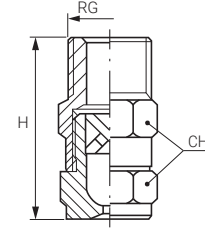

BC



THREAD SPECIFICATION:  
**BC:** Male ( BSPT, NPT )  
**BA:** Female ( BSP, NPT )

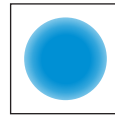

Spray section

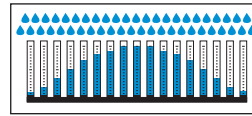

Convex distribution

BAQ Female	BCQ Male	CODE	RF RG inch	D mm	D1 mm	Capacity at different pressure values (l/min) (bar)							Spray angle at pressure (°) (bar)		
						0.7	1.0	2.0	3.0	5.0	7.0	10	0.5	1.5	6.0
•	•	<b>0740</b>	1/8"	1.0	0.5	0.36	0.43	0.60	0.74	0.96	1.13	1.35	—	58°	53°
•	•	<b>1110</b>		1.2	0.5	0.53	0.64	0.90	1.10	1.42	1.68	2.01	52°	65°	59°
•	•	<b>1150</b>		1.4	1.0	0.72	0.87	1.22	1.50	1.94	2.29	2.74	43°	50°	46°
•	•	<b>1220</b>		1.6	1.0	1.06	1.27	1.80	2.20	2.84	3.36	4.02	52°	65°	59°
•	•	<b>1260</b>		1.6	1.3	1.26	1.50	2.12	2.60	3.36	3.97	4.75	43°	50°	46°
•	•	<b>1370</b>	2.0	1.3	1.79	2.14	3.02	3.70	4.78	5.65	6.76	52°	65°	59°	
•	•	<b>1480</b>	1/4"	2.4	1.7	2.32	2.77	3.92	4.80	6.20	7.33	8.76	45°	50°	46°
•	•	<b>1740</b>		2.9	1.7	3.57	4.27	6.04	7.40	9.55	11.3	13.5	58°	67°	61°
•	•	<b>1930</b>		3.2	1.7	4.49	5.37	7.59	9.30	12.0	14.2	17.0	69°	74°	68°
•	•	<b>1700</b>	3/8"	3.0	2.0	3.38	4.04	5.72	7.00	9.04	10.7	12.8	45°	50°	46°
•	•	<b>2111</b>		3.4	2.4	5.36	6.41	9.06	11.1	14.3	17.0	20.3	64°	67°	61°
•	•	<b>2163</b>		4.5	2.4	7.87	9.41	13.3	16.3	21.0	24.9	29.8	87°	90°	82°
•	•	<b>2118</b>	1/2"	3.4	3.0	5.70	6.81	9.63	11.8	15.2	18.0	21.5	48°	50°	46°
•	•	<b>2185</b>		4.4	3.0	8.94	10.7	15.1	18.5	23.9	28.3	33.8	64°	67°	61°
•	•	<b>2240</b>		5.0	3.0	11.6	13.9	19.6	24.0	31.0	36.7	43.8	72°	75°	68°
•	•	<b>2300</b>		5.6	3.0	14.5	17.3	24.5	30.0	38.7	45.8	54.8	88°	91°	83°

STANDARD SPRAY

BAW	BCW	CODE	RF/RG	D	D1	0.7	1.0	2.0	3.0	5.0	7.0	10	0.3	0.7	6.0
•	•	<b>1200</b>	1/8"	1.5	1.0	0.97	1.15	1.63	2.00	2.58	3.06	3.65	—	120°	102°
•	•	<b>1310</b>		1.8	1.0	1.50	1.79	2.53	3.10	4.00	4.74	5.66	—	120°	102°
•	•	<b>1400</b>		2.3	1.0	1.93	2.31	3.27	4.00	5.16	6.11	7.30	—	120°	102°
•	•	<b>1570</b>		2.5	1.1	2.75	3.29	4.65	5.70	7.36	8.71	10.4	—	120°	103°
•	•	<b>1720</b>	1/4"	3.3	1.7	3.48	4.16	5.88	7.20	9.30	11.0	13.1	112°	120°	103°
•	•	<b>1860</b>		3.4	1.3	4.15	4.97	7.02	8.60	11.1	13.1	15.7	114°	120°	103°
•	•	<b>2100</b>		3.6	1.6	4.83	5.77	8.16	10.0	12.9	15.3	18.3	114°	120°	103°
•	•	<b>2122</b>	3/8"	3.9	1.6	5.89	7.04	9.96	12.2	15.8	18.6	22.3	114°	120°	103°
•	•	<b>2144</b>		4.3	2.4	6.96	8.31	11.8	14.4	18.6	22.0	26.3	114°	120°	104°
•	•	<b>2172</b>		4.9	2.4	8.31	9.93	14.0	17.2	22.2	26.3	31.4	114°	120°	104°
•	•	<b>2194</b>		5.3	2.5	9.37	11.2	15.8	19.4	25.0	29.6	35.4	114°	120°	106°
•	•	<b>2220</b>	1/2"	5.0	3.0	10.6	12.7	18.0	22.0	28.4	33.6	40.2	114°	120°	108°
•	•	<b>2250</b>		5.3	3.0	12.1	14.4	20.4	25.0	32.3	38.2	45.6	114°	120°	108°
•	•	<b>2290</b>		5.6	3.0	14.0	16.7	23.7	29.0	37.4	44.3	52.9	114°	120°	108°
•	•	<b>2320</b>		6.7	3.5	15.5	18.5	26.1	32.0	41.3	48.9	58.4	114°	120°	110°
•	•	<b>2360</b>		7.6	4.0	17.4	20.8	29.4	36.0	46.5	55.0	65.7	114°	120°	112°

WIDE SPRAY

TYPICAL APPLICATIONS

- Washing:**  
 Exhaust scrubbers  
 Parts cleaning  
 Pre-treatment for coating process
- Cooling:**  
 Exhaust cooling  
 Tank cooling
- Dust control:**  
 Remove dust flying in a mining and coal plants.
- Other applications:**  
 Spray of chemicals  
 Fire engineering

NOZZLE TYPE	RF inch	H mm	WS mm	W kg
BA Female	1/8"	30	14	0.03
	1/4"	37	17	0.04
	3/8"	46	19	0.07
	1/2"	57	25	0.20

NOZZLE TYPE	RG inch	H mm	WS mm	W kg
BC Male	1/8"	32	14	0.02
	1/4"	39	17	0.04
	3/8"	47	19	0.07
	1/2"	57	25	0.20

DIMENSIONS & WEIGHTS

HOW TO MAKE UP THE NOZZLE CODE  
 Ex.: BAQ 0740 B1

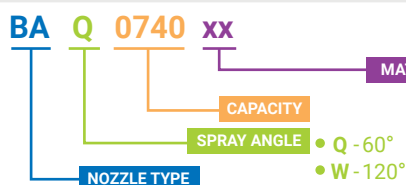

- **B1** - AISI 303 Stainless steel
- **B31** - AISI 316L Stainless steel
- **T1** - Brass
- **E1** - PTFE
- **L61** - Hastelloy C22

# BB / BD ( FULL CONE NOZZLES / CLEANABLE )

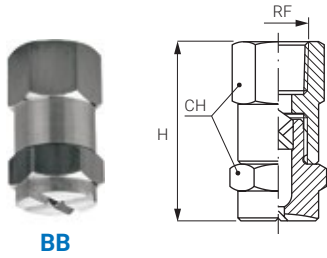

BB

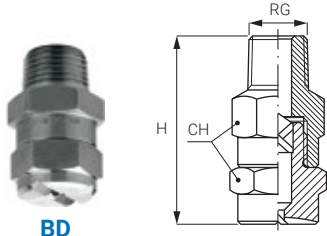

BD

X VANE / SQUARE SPRAY PATTERN / THREE-PIECE DESIGN / EASY CLEAN

BB/BD series full cone nozzles offer a three-piece design made of body, X-vane and connection. BB/BD series nozzles supply a square section spray pattern and are suitable for working environments that strictly require a uniform coverage. The most important feature of BB/BD series nozzle is their X-vane which can be easily disassembled. It is mounted between its body and connection, allowing the narrowest passage to avoid clogging. The best choice to solve clogging problems.

THREAD SPECIFICATION:

**BD:** Male ( BSPT, NPT )

**BB:** Female ( BSP, NPT )

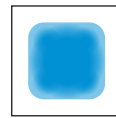

Spray section

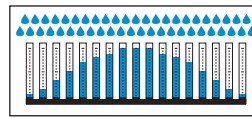

Convex distribution



## SQUARE SPRAY

BBQ Female	BDQ Male	CODE	RF RG inch	D mm	D1 mm	Capacity at different pressure values							Spray angle at pressure		
						(l/min) (bar)							(°) (bar)		
						0.7	1.0	2.0	3.0	5.0	7.0	10	0.5	1.5	6.0
•	•	1270	1/8"	1.8	1.0	1.30	1.56	2.20	2.70	3.49	4.12	4.93	40°	52°	47°
•	•	1360		1.9	1.3	1.74	2.08	2.94	3.60	4.65	5.50	6.57	48°	63°	57°
•	•	1440		2.1	1.3	2.13	2.54	3.59	4.40	5.68	6.72	8.03	60°	66°	60°
•	•	1740	1/4"	2.8	1.6	3.57	4.27	6.04	7.40	9.55	11.3	13.5	62°	67°	61°
•	•	1890		3.2	1.6	4.30	5.14	7.27	8.90	11.5	13.6	16.2	70°	75°	68°
•	•	2110		3.8	1.6	5.31	6.35	8.98	11.0	14.2	16.8	20.1	78°	82°	75°
•	•	2133	3/8"	3.8	2.4	6.42	7.68	10.9	13.3	17.2	20.3	24.3	71°	75°	68°
•	•	2210	1/2"	5.6	3.0	10.1	12.1	17.1	21.0	27.1	32.1	38.3	71°	75°	68°
•	•	2270		6.4	3.2	13.0	15.6	22.0	27.0	34.9	41.2	49.3	78°	82°	75°

BB/BD series nozzles produce a square spray pattern. The flat spray orientation is set with a 10°-15° offset angle from the main manifold axis to avoid jet overlapping. Therefore the correct alignment of these nozzles is very important and must be done properly. Please refer to the table below.



## DIMENSIONS AND WEIGHTS

NOZZLE TYPE	RF inch	H mm	WS mm	W kg
BB Female	1/8"	30	14	0.03
	1/4"	37	17	0.04
	3/8"	46	19	0.07
	1/2"	57	25	0.20

NOZZLE TYPE	RG inch	H mm	WS mm	W kg
BD Male	1/8"	32	14	0.02
	1/4"	39	17	0.04
	3/8"	47	19	0.07
	1/2"	57	25	0.20

## TYPICAL APPLICATIONS

*Washing:* exhaust scrubbers, parts cleaning, pre-treatment for coating processes

*Cooling:* exhaust gas cooling, tank cooling

*Coating:* oil coating, spray of chemicals

*Other applications:* dust control, leak test

## HOW TO MAKE UP THE NOZZLE CODE

Ex.: BBQ 1270 B1

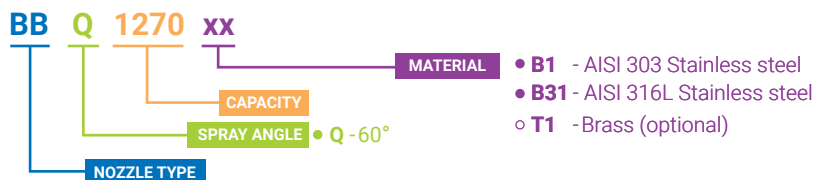

# ( FULL CONE NOZZLES / SQUARE SPRAY ) BF / BH

## X-VANE / SQUARE SPRAY PATTERN / TWO-PIECE DESIGN

BF/BH type nozzles have a simple two-piece design producing a square section spray pattern. They are the convenient choice where the coverage of a surface is required to be as even as possible. Their X-vane ensures uniform spray distribution and resistance to clogging, also when working with large capacities. The sides of the square spray section are not aligned with the



grooves of the nozzle orifice and the offset angle is between 10° and 15° depending on working pressure and distance from the impact surface. Therefore, utmost attention must be paid during the nozzles overlay setting. They must be carefully aligned and adjusted according to the operating situation.

### THREAD SPECIFICATION

- BH:** Male (BSPT, NPT)
- BF:** Female (BSP, NPT)



BH



BF

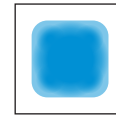

Spray section

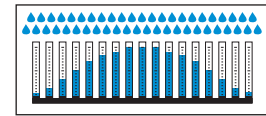

Convex distribution

BFS Female	BHQ Male	CODE	RF RG inch	D mm	D1 mm	Capacity at different pressure values (l/min) (bar)							Spray angle at pressure (°) (bar)			
						0.7	1.0	2.0	3.0	5.0	7.0	10	0.5	1.5	3.0	6.0
	•	1270	1/8"	1.7	1.3	1.30	1.56	2.21	2.70	3.49	4.12	4.93	40°	52°	60°	47°
	•	1350		1.9	1.3	1.69	2.02	2.86	3.50	4.52	5.35	6.39	48°	63°	60°	57°
	•	1440		2.2	1.3	2.13	2.54	3.59	4.40	5.68	6.72	8.03	60°	66°	65°	60°
	•	1740	1/4"	2.8	1.6	3.58	4.27	6.04	7.40	9.55	11.3	13.5	62°	67°	65°	61°
	•	1890		3.2	1.6	4.30	5.14	7.27	8.90	11.5	13.6	16.3	70°	75°	65°	68°
	•	2107		3.8	1.6	5.17	6.18	8.74	10.7	13.8	16.3	19.5	78°	82°	65°	75°
	•	2133	3/8"	4.0	2.4	6.42	7.68	10.9	13.3	17.2	20.3	24.3	71°	75°	62°	68°
	•	2210	1/2"	5.5	3.2	10.1	12.1	17.1	21.0	27.1	32.1	38.3	71°	75°	64°	68°
	•	2270		6.4	3.2	13.0	15.6	22.1	27.0	34.9	41.2	49.3	78°	82°	65°	75°
	•	2370	3/4"	6.7	4.4	17.9	21.4	30.2	37.0	47.8	56.5	67.6	71°	75°	64°	68°
	•	2780	1"	1.9	1.3	37.7	45.0	63.7	78.0	101	119	142	78°	80°	78°	73°
	•	3131	1 1/4"	2.4	1.3	63.3	75.6	107	131	169	200	239	78°	80°	78°	73°
	•	3170	1 1/2"	2.8	1.6	82.1	98.1	139	170	219	260	310	73°	77°	78°	70°
	•	3215	2"	3.2	1.6	104	124	176	215	278	328	393	66°	70°	72°	64°
	•	3265		3.8	1.6	128	153	216	265	342	405	484	70°	74°	75°	67°
	•	3355		1.6	1.3	171	205	290	355	458	542	648	79°	82°	75°	74°
	•	3360	2 1/2"	1.9	1.3	174	208	294	360	465	550	657	62°	67°	70°	61°
	•	3435		2.4	1.3	210	251	355	435	562	664	794	75°	78°	80°	71°
	•	3700		2.8	1.6	338	404	572	700	904	1069	1278	81°	84°	76°	76°
	•	4220	5"	1.9	1.3	1063	1270	1796	2200	2840	3361	4017	89°	91°	75°	83°
	•	4420	6"	2.4	1.3	2029	2425	3429	4200	5422	6416	7668	102°	105°	78°	95°

### STANDARD SPRAY ANGLE

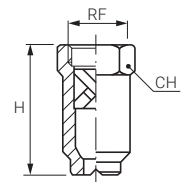
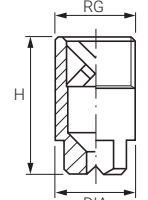
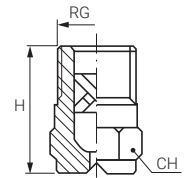

BFW Female	BHW Male	CODE	RF RG mm	D mm	D1 mm	Capacity (l/min) at different pressure values (bar)							Spray angle (°) at pressure (bar)		
						0.7	1.0	2.0	3.0	5.0	7.0	10	0.3	0.7	6.0
	•	2100	1/4"	3.2	1.6	4.83	5.77	8.16	10.0	12.9	15.3	18.3	99°	101°	93°
	•	2122	3/8"	3.9	1.6	5.89	7.04	9.96	12.2	15.8	18.6	22.3	99°	101°	93°
	•	2144		4.0	2.4	6.96	8.31	11.8	14.4	18.6	22.0	26.3	104°	110°	94°
	•	2172		4.6	2.4	8.31	9.93	14.0	17.2	22.2	26.3	31.4	104°	110°	94°
	•	2194		5.4	2.4	9.37	11.2	15.8	19.4	25.0	29.6	35.4	104°	110°	98°
	•	2220	1/2"	4.8	3.0	10.6	12.7	18.0	22.0	28.4	33.6	40.2	104°	110°	102°
	•	2250		5.1	3.0	12.1	14.4	20.4	25.0	32.3	38.2	45.6	104°	110°	102°
	•	2290		5.7	3.0	14.0	16.7	23.7	29.0	37.4	44.3	52.9	104°	110°	102°
	•	2320		7.0	3.0	15.5	18.5	26.1	32.0	41.3	48.9	58.4	104°	110°	102°
	•	2360		8.0	3.0	17.4	20.8	29.4	36.0	46.5	55.0	65.7	104°	110°	102°
	•	2500	3/4"	8.5	4.5	24.2	28.9	40.8	50.0	64.6	76.4	91.3	105°	110°	102°
	•	2930	1"	11.6	5.6	44.9	53.7	75.9	93.0	120	142	170	107°	110°	107°
	•	3134	1 1/4"	14.5	6.0	64.7	77.4	109	134	173	205	245	108°	111°	109°
	•	3200	1 1/2"	18.2	9.0	96.6	115	163	200	258	306	365	109°	114°	109°
	•	3395	2"	24.0	11.1	191	228	323	395	510	603	721	110°	114°	109°
	•	3590	2 1/2"	26.0	14.3	285	341	482	590	762	901	1077	110°	115°	109°
	•	3800	3"	31.5	17.5	386	462	653	800	1033	1222	1461	110°	115°	109°

### WIDE SPRAY ANGLE

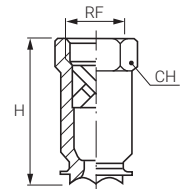
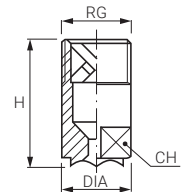
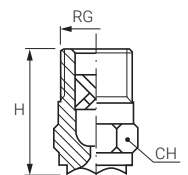

Dim. inch	1/8"	1/4"	3/8"	1/2"	3/4"	1"	1 1/4"	1 1/2"	2"	2 1/2"	3"	5"	6"
H mm	22	23	30	39	55	70	88	102	138	175	187	311	366
CH mm	12	14	17	21	27	32	40	50	60	85	100	170	200
DIA mm					32	38							
W kg	0.01	0.02	0.03	0.04	0.20	0.35	0.55	0.80	1.6	2.0	7.8	18	25

### DIMENSIONS AND WEIGHTS

### HOW TO MAKE UP THE NOZZLE CODE

EX.: BFS 2780 B1

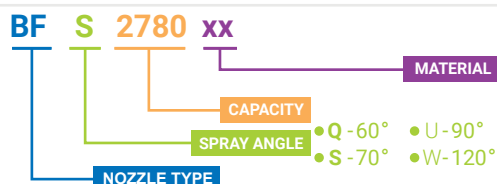

- B1 - AISI 303 Stainless steel
- B31 - AISI 316L Stainless steel
- T1 - Brass



# BE / BG ( FULL CONE NOZZLES )

## X-VANE / ROUND SPRAY / TWO-PIECE DESIGN

BE/BG series nozzles have a two-piece design producing a full cone round spray pattern with angles ranging between 70° and 120° and capacities from 4.8 and 1.040 l/min. Their X-vane ensures uniform spray distribution and resistance to clogging, also when working with large capacities. For this important feature these nozzles are a widely popular choice. The table on this page shows BE/BG threaded nozzles up to size 3".



BE

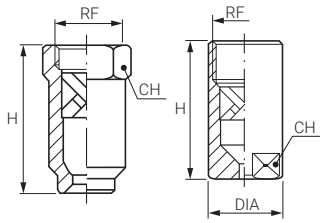

BG

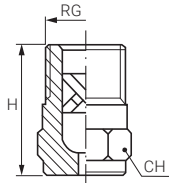

### THREAD SPECIFICATION

- BG: Male (BSPT, NPT)
- BE: Female (BSP, NPT)

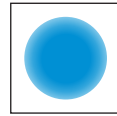

Spray section

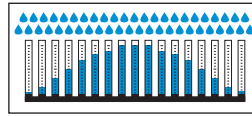

Convex distribution



### STANDARD SPRAY ANGLES

#### TYPICAL APPLICATIONS

- Washing:
- Food cleaning
- Parts cleaning
- Pre-treatment for coating process
- Cooling:
- Steel cooling
- Product cooling
- Tank cooling
- Other applications:
- Desulfuration
- Leak test

#### MATERIAL

- B1 AISI 303
- B31 AISI 316L
- T1 Brass, only size 1" and smaller
- E1 PTFE
- L61 Hastelloy C22

NOZZLE TYPE		CODE	RF RG inch	D mm	D1 mm	Capacity at different pressure values							Spray angle at pressure		
BES Female	BGQ Male					(l/min) (bar)							(°) (bar)		
						0.5	1.0	2.0	3.0	5.0	7.0	10	0.5	1.5	6.0
	•	1480 xx	1/4"	2.3	1.6	1.96	2.77	3.92	4.80	6.20	7.33	8.76	45°	50°	46°
	•	1740 xx		2.9	1.6	3.02	4.27	6.04	7.40	9.55	11.3	13.5	58°	67°	61°
	•	1700 xx	3/8"	2.6	2.4	2.86	4.04	5.72	7.00	9.04	10.7	12.8	45°	50°	46°
	•	2111 xx		3.6	2.4	4.53	6.41	9.06	11.1	14.3	17.0	20.3	64°	67°	61°
	•	2163 xx		4.5	2.8	6.65	9.41	13.3	16.3	21.0	24.9	29.8	87°	90°	82°
	•	2185 xx	1/2"	4.6	3.2	7.55	10.7	15.1	18.5	23.9	28.3	33.8	64°	67°	61°
	•	2300 xx		6.3	3.6	12.3	17.3	24.5	30.0	38.7	45.8	54.8	88°	91°	83°
	•	2220 xx	3/4"	4.9	4.4	8.98	12.7	18.0	22.0	28.4	33.6	40.2	48°	50°	46°
	•	2350 xx		6.4	4.4	14.3	20.2	28.6	35.0	45.2	53.5	63.9	67°	70°	63°
	•	2610 xx		9.5	5.2	24.9	35.2	49.8	61.0	78.8	93.2	111	89°	92°	84°
	•	2370 xx	1"	6.0	5.6	15.1	21.4	30.2	37.0	47.8	56.5	67.6	48°	50°	46°
	•	2611 xx		8.3	5.6	24.9	35.2	49.8	61.0	78.8	93.2	111	67°	68°	62°
	•	2870 xx		11.9	5.6	35.5	50.2	71.0	87.0	112	133	159	78°	90°	94°
	•	3104 xx		11.9	6.4	42.5	60.0	84.9	104	134	159	190	89°	92°	84°
	•	2520 xx	1 1/4"	7.4	6.4	21.2	30.0	42.5	52.0	67.1	79.4	95	48°	50°	44°
	•	2871 xx		9.6	6.4	35.5	50.2	71.0	87.0	112	133	159	64°	67°	58°
	•	3105 xx		10.7	6.4	42.9	60.6	85.7	105	136	160	192	66°	70°	60°
	•	3122 xx		12.3	6.4	49.8	70.4	99.6	122	158	186	222	77°	80°	70°
	•	3174 xx		15.1	7.9	71.0	100	142	174	225	266	318	90°	93°	81°
	•	2872 xx	1 1/2"	9.5	8.7	35.5	50.2	71.0	87.0	112	133	159	48°	50°	44°
	•	3139 xx		12.7	8.7	56.8	80.3	113	139	180	212	254	72°	74°	64°
	•	3175 xx		14.3	8.7	71.4	101	143	175	226	267	320	74°	76°	66°
	•	3260 xx		18.3	10.3	106	150	212	260	336	397	475	91°	94°	82°
	•	3148 xx	2"	12.7	11.1	60.4	85.5	121	148	191	226	270	49°	50°	44°
	•	3261 xx		17.3	11.1	106	150	212	260	336	397	475	72°	74°	64°
	•	3305 xx		19.2	11.1	125	176	249	305	394	466	557	75°	77°	68°
	•	3350 xx		21.0	11.1	143	202	286	350	452	535	639	78°	80°	70°
	•	3435 xx		23.8	14.3	178	251	355	435	562	665	794	83°	85°	75°
	•	3520 xx		28.6	14.3	212	300	425	520	671	794	949	98°	100°	86°
	•	3215 xx	2 1/2"	15.1	14.3	87.8	124	176	215	278	328	393	49°	50°	44°
	•	3436 xx		22.2	14.3	178	251	355	435	562	665	794	72°	74°	64°
	•	3521 xx		24.6	14.3	212	300	425	520	671	794	949	76°	78°	68°
	•	3610 xx		28.6	14.3	249	352	498	610	788	932	1114	79°	82°	72°
	•	3700 xx		28.6	17.5	286	404	572	700	904	1069	1278	86°	88°	77°
	•	3780 xx		31.8	17.5	318	450	637	780	1007	1192	1424	95°	97°	84°
	•	3365 xx	3"	19.1	17.5	149	211	298	365	471	558	666	49°	50°	44°
	•	3701 xx		27.8	17.5	286	404	572	700	904	1069	1278	81°	84°	73°
	•	3781 xx		30.2	17.5	318	450	637	780	1007	1192	1424	86°	89°	77°
	•	3870 xx		32.5	17.5	355	502	710	870	1123	1329	1588	92°	95°	83°
	•	4104 xx		34.9	20.6	425	600	849	1040	1343	1589	1899	102°	105°	89°

### DIMENSIONS

BG Male	Dim.	inch	1/4"	3/8"	1/2"	3/4"	1"	1 1/4"	1 1/2"	2"	2 1/2"	3"
	H	mm	22.0	25.0	33.0	40.0	51.5					
CH	mm	14.0	17.0	22.0	22.0	27.0						
BE Female	H	mm				55.5	68.0	90.0	105	140	180	192
	DIA	mm				32.0	38.0					
	CH	mm				27.0	32.0	48.0	52.0	67.0	85.0	100



( FULL CONE NOZZLES ) **BE / BG**

WIDE SPRAY ANGLES

NOZZLE TYPE		CODE	RF RG	D mm	D1 mm	Capacity at different pressure values								Spray angle at pressure		
BEW Female	BGW Male					(l/min) (bar)								(°)		
						0.5	1.0	2.0	3.0	5.0	7.0	10	0.3	0.7	6.0	
	•	<b>2100 xx</b>	1/4"	3.3	1.6	4.08	5.77	8.16	10.0	12.9	15.3	18.3	114°	120°	103°	
	•	<b>2122 xx</b>	3/8"	3.6	2.4	4.98	7.04	9.96	12.2	15.8	18.6	22.3	114°	120°	103°	
	•	<b>2144 xx</b>		4.0	2.4	5.88	8.31	11.8	14.4	18.6	22.0	26.3	114°	120°	104°	
	•	<b>2172 xx</b>		5.1	2.4	7.02	9.93	14.0	17.2	22.2	26.3	31.4	114°	120°	104°	
	•	<b>2194 xx</b>		5.2	2.8	7.92	11.2	15.8	19.4	25.0	29.6	35.4	114°	120°	106°	
	•	<b>2220 xx</b>	1/2"	5.0	3.0	8.98	12.7	18.0	22.0	28.4	33.6	40.2	114°	120°	108°	
	•	<b>2250 xx</b>		5.4	3.0	10.2	14.4	20.4	25.0	32.3	38.2	45.6	114°	120°	108°	
	•	<b>2290 xx</b>		6.4	3.0	11.8	16.7	23.7	29.0	37.4	44.3	52.9	114°	120°	108°	
	•	<b>2320 xx</b>		6.9	3.0	13.1	18.5	26.1	32.0	41.3	48.9	58.4	114°	120°	110°	
	•	<b>2360 xx</b>		7.6	3.0	14.7	20.8	29.4	36.0	46.5	55.0	65.7	114°	120°	112°	
•	•	<b>2500 xx</b>	3/4"	8.7	4.5	20.4	28.9	40.8	50.0	64.5	76.4	91.3	115°	120°	112°	
•	•	<b>2920 xx</b>	1"	11.5	5.6	37.6	53.1	75.1	92.0	119	141	168	117°	120°	117°	
•	•	<b>3134 xx</b>	1 1/4"	14.0	6.0	54.7	77.4	109	134	173	205	245	118°	121°	119°	
•	•	<b>3200 xx</b>	1 1/2"	16.5	9.0	81.6	115	163	200	258	306	365	119°	124°	119°	
•	•	<b>3395 xx</b>	2"	24.0	11.1	161	228	323	395	510	603	721	120°	124°	119°	
•	•	<b>3590 xx</b>	2 1/2"	26.0	14.3	241	341	482	590	762	901	1077	120°	125°	119°	
•	•	<b>3800 xx</b>	3"	32.0	17.5	327	462	653	800	1033	1222	1461	120°	125°	119°	

X-VANE / LARGE CAPACITIES

BE/BL series large capacity nozzles feature a full cone spray pattern with uniform distribution over a round impact area, ranging between 90° and 120° and for applications where a very large capacity is required. The bodies are machined from a casting, and can be finished either with a female thread connection (BE type) or with an integral ANSI flange (BL type).

THREAD SPECIFICATION : BSP, NPT

FLANGE SPECIFICATION : DIN Standard, JIS Standard (optional)

TYPICAL APPLICATIONS : desulfuration, coke quenching

( FULL CONE NOZZLES ) **BE / BL**

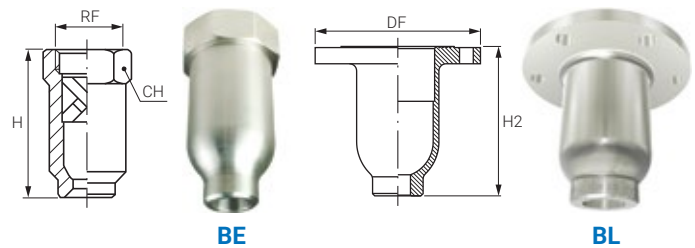

LARGE CAPACITY

NOZZLE TYPE	CODE	RF RG	D mm	D1 mm	Capacity at different pressure values								Spray angle at pressure			Dimensions mm		
					(l/min) (bar)								(°)			mm		
					0.7	1.0	2.0	3.0	5.0	7.0	10	0.5	1.5	6.0	H	H2	WS	
90°	• • <b>4139 xx</b>	4"	43	19	671	803	1135	1390	1794	2123	2538	87°	90°	70°	251	207	130	
	• • <b>4157 xx</b>		47	22	758	906	1282	1570	2027	2398	2866	92°	95°	83°				
	• • <b>4174 xx</b>		51	25	840	1005	1421	1740	2246	2658	3177	97°	100°	87°				
	• • <b>4183 xx</b>		54	25	884	1057	1494	1830	2363	2795	3341	102°	105°	91°				
	• • <b>4218 xx</b>	5"	48	29	1053	1259	1780	2180	2814	3330	3980	89°	91°	80°	311	269	170	
	• • <b>4244 xx</b>		53	29	1179	1409	1992	2440	3150	3727	4455	93°	96°	84°				
	• • <b>4279 xx</b>		68	35	1348	1611	2278	2790	3602	4262	5094	97°	100°	87°				
	• • <b>4287 xx</b>		73	35	1386	1657	2343	2870	3705	4384	5240	102°	105°	91°				
	• • <b>4305 xx</b>	6"	61	41	1473	1761	2490	3050	3938	4659	5569	87°	90°	78°	366	321	200	
	• • <b>4348 xx</b>		70	41	1681	2009	2841	3480	4493	5316	6354	92°	95°	83°				
	• • <b>4392 xx</b>		77	44	1894	2263	3201	3920	5061	5988	7157	97°	100°	87°				
	• • <b>4418 xx</b>		82	44	2019	2413	3413	4180	5396	6385	7632	102°	105°	91°				
	• • <b>4435 xx</b>	8"	70	48	2101	2511	3552	4350	5616	6645	7942	78°	80°	70°	470	423	240	
	• • <b>4520 xx</b>		80	47	2512	3002	4246	5200	6713	7943	9494	86°	88°	77°				
	• • <b>4610 xx</b>		91	47	2947	3522	4981	6100	7875	9318	11137	92°	95°	83°				
	• • <b>4694 xx</b>		102	57	3352	4007	5666	6940	8960	10601	12671	102°	105°	91°				
• • <b>4785 xx</b>		124	57	3792	4532	6409	7850	10134	11991	14332	106°	110°	96°					
• • <b>4695 xx</b>	10"	102	57	3357	4013	5675	6950	8972	10616	12689	78°	80°	70°		527			
• • <b>4870 xx</b>		102	64	4202	5023	7104	8700	11232	13289	15884	86°	89°	77°					
• • <b>5104 xx</b>		122	67	5024	6004	8492	10400	13426	15886	18988	97°	100°	87°					
• • <b>5113 xx</b>		135	67	5458	6524	9226	11300	14588	17261	20631	103°	106°	92°					

NOZZLE TYPE	CODE	RF RG	D	D1	Capacity (l/min) at different pressure values (bar)								Dimensions (mm)	
					0.7	1.0	2.0	3.0	5.0	7.0	10	H	WS	
120°	• <b>4158 xx</b>	4"	47	22	758	906	1282	1570	2027	2398	2538	251	130	

HOW TO MAKE UP THE NOZZLE CODE

Ex.: BEU 4139 B31

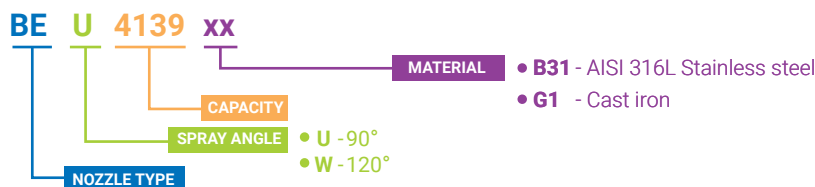

# BR / BS / BT / BU ( FULL CONE NOZZLES )

X-VANE / NARROW SPRAY ANGLE



BR/BU nozzles produce a solid cone spray with round spray pattern, where coarse water drops are concentrated within a narrow spray angle to maximize their impact force per square surface unit. Spray angle values of 15° or 30° are available, with a choice of male or female thread connections. BR/BS nozzles are made of three pieces designed to allow their easy disassembly and cleaning in case of clogging.

THREAD SPECIFICATION

**BS / BT:** Male (BSPT, NPT)

**BR / BU:** Female (BSP, NPT)

TYPICAL APPLICATIONS

bottles washing, parts cleaning, deep cleaning

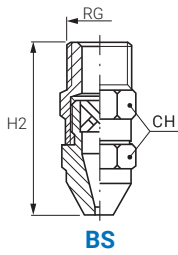
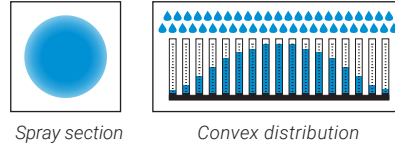

BS

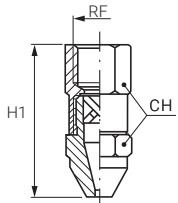

BR

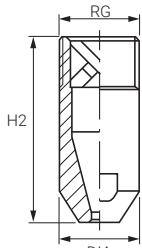

BT

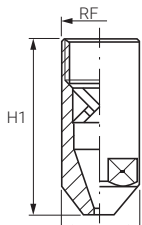

BU

SPRAY ANGLE 15°

BRB Female	BSB Male	BUB Female	CODE	RF RG inch	D mm	Capacity at different pressure values (l/min) (bar)					Dimensions mm			
						1.0	2.0	3.0	5.0	10	DIA	H1	H2	CH
•	•		1270 xx	1/8"	1.6	1.56	2.20	2.70	3.49	4.93		33	35	12
•	•		1550 xx		2.3	3.18	4.49	5.50	7.10	10.0				
•	•		2117 xx	1/4"	3.2	6.75	9.55	11.7	15.1	21.4		44	44	17
•	•		2196 xx	3/8"	4.2	11.3	16.0	19.6	25.3	35.8		53	53	22
•	•		2352 xx	1/2"	5.6	20.3	28.7	35.2	45.4	64.3		72	72	24
		•	2587 xx	3/4"	7.8	33.9	47.9	58.7	75.8	107	32	72		25
		•	3110 xx	1"	10.2	63.5	89.8	110	142	201	40	92		35
		•	3168 xx	1 1/4"	12.6	97.0	137	168	217	307	48	117		40
		•	3245 xx	1 1/2"	15.1	141	200	245	316	447	60	127		52
		•	3450 xx	2"	22.0	260	367	450	581	822	80	183		70
		•	3680 xx	2 1/2"	26.0	393	555	680	878	1242	90	223		85
		•	3980 xx	3"	31.0	566	800	980	1265	1789	105	268		100

SPRAY ANGLE 30°

BRF Female	BSF Male	BTF Male	CODE	RF RG inch	D mm	Capacity at different pressure values (l/min) (bar)					Dimensions mm			
						1.0	2.0	3.0	5.0	10	DIA	H1	H2	CH
•	•		0980 xx	1/8"	1.0	0.57	0.80	0.98	1.27	1.79		33	35	12
•	•		1160 xx		1.2	0.92	1.31	1.60	2.07	2.92				
•	•		1270 xx		1.6	1.56	2.20	2.70	3.49	4.93				
•	•		1350 xx	1/4"	1.8	2.02	2.86	3.50	4.52	6.39		44	44	17
•	•		1550 xx	3/8"	2.3	3.18	4.49	5.50	7.10	10.0		53	53	22
•	•		2117 xx	1/2"	3.2	6.75	9.55	11.7	15.1	21.4		72	72	24
•	•		2195 xx	3/4"	4.2	11.3	15.9	19.5	25.2	35.6		84	87	25
		•	2270 xx	1"	5.1	15.6	22.0	27.0	34.9	49.3	34		92	
		•	2390 xx		6.1	22.5	31.8	39.0	50.3	71.2				27
		•	2590 xx	1 1/4"	7.4	34.1	48.2	59.0	76.2	108				
		•	2780 xx		8.6	45.0	63.7	78.0	101	142	44		127	35
		•	2980 xx	1 1/2"	9.6	56.6	80.0	98.0	127	179				40
		•	3117 xx		10.5	67.5	95.5	117	151	214	50		155	
		•	3137 xx	2"	11.1	79.1	112	137	177	250	60		200	55
		•	3156 xx		11.9	90.1	127	156	201	285				
		•	3195 xx		13.5	113	159	195	252	356				
		•	3235 xx		14.7	136	192	235	303	429				60
		•	3275 xx	2 1/2"	15.9	159	225	275	355	502				
		•	3390 xx		19.1	225	318	390	503	712	75		264	
		•	3430 xx		19.8	248	351	430	555	785				
		•	3470 xx		20.6	271	384	470	607	858				

HOW TO MAKE UP THE NOZZLE CODE

EX.: BRB 1270 B1

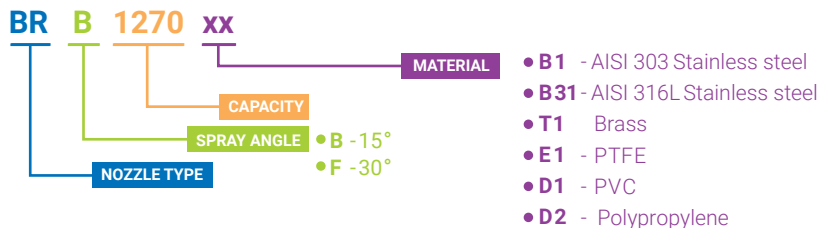

( FULL CONE NOZZLES / TANGENTIAL ) **BV / BW**

OFF LINE SPRAY

BV/BW series are two-piece nozzles with a 90° elbow coupling that produce a mist spray. Their special design with X-vane breaks the liquid into fine droplets and allows an easy cleaning. They may be supplied with male or female threaded connection.



THREAD SPECIFICATION

**BV:** Male (BSPT, NPT)  
**BW:** Female (BSP, NPT)

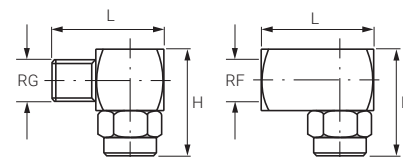
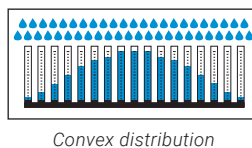
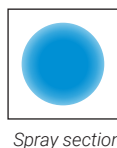

**BV**

**BW**

SPRAY ANGLE 60°

60°	BVQ Male	BWQ Female	CODE	RF RG inch	Capacity at different pressure values (l/min) (bar)						Dimensions mm	
					0.5	1.0	2.0	3.0	5.0	10	H	L
					•	•	<b>1150 XX</b>	1/8"	0.61	0.87	1.22	1.50
•	•	<b>1220 XX</b>		0.90	1.27	1.80	2.20	2.84	4.02			
•	•	<b>1260 XX</b>		1.06	1.50	2.12	2.60	3.36	4.75			
•	•	<b>1290 XX</b>		1.18	1.67	2.37	2.90	3.74	5.29			
•	•	<b>1370 XX</b>		1.51	2.14	3.02	3.70	4.78	6.76			
•	•	<b>1450 XX</b>		1.84	2.60	3.67	4.50	5.81	8.22			
•	•	<b>1480 XX</b>	1/4"	1.96	2.77	3.92	4.80	6.20	8.76	32	32.0	
•	•	<b>1740 XX</b>		3.02	4.27	6.04	7.40	9.55	13.5			
•	•	<b>1930 XX</b>		3.80	5.37	7.59	9.30	12.0	17.0			
•	•	<b>1700 XX</b>	3/8"	2.86	4.04	5.72	7.00	9.04	12.8	35	32.5	
•	•	<b>2111 XX</b>		4.53	6.41	9.06	11.1	14.3	20.3			
•	•	<b>2144 XX</b>		5.88	8.31	11.8	14.4	18.6	26.3			
•	•	<b>2163 XX</b>		6.65	9.41	13.3	16.3	21.0	29.8			
•	•	<b>2118 XX</b>	1/2"	4.82	6.81	9.63	11.8	15.2	21.5	50	40.0	
•	•	<b>2185 XX</b>		7.55	10.7	15.1	18.5	23.9	33.8			
•	•	<b>2240 XX</b>		9.80	13.9	19.6	24.0	31.0	43.8			
•	•	<b>2300 XX</b>		12.3	17.3	24.5	30.0	38.7	54.8			
•	•	<b>2360 XX</b>		14.7	20.8	29.4	36.0	46.5	65.7			

TYPICAL APPLICATIONS

- Washing:  
Parts washing  
Gas scrubbing  
Food washing
- Cooling:  
Parts cooling  
Gas cooling  
Tank cooling

SPRAY ANGLE 120°

120°	BVW Male	BWW Female	CODE	RF RG inch	Capacity at different pressure values (l/min) (bar)						Dimensions mm	
					0.5	1.0	2.0	3.0	5.0	10	H	L
					•	•	<b>1310 XX</b>	1/8"	1.27	1.79	2.53	3.10
•	•	<b>1570 XX</b>		2.33	3.29	4.65	5.70	7.36	10.4			
•	•	<b>2100 XX</b>	1/4"	4.08	5.77	8.16	10.0	12.9	18.3	32	32.0	
•	•	<b>2144 XX</b>	3/8"	5.88	8.31	11.8	14.4	18.6	26.3	35	32.5	
•	•	<b>2250 XX</b>	1/2"	10.2	14.4	20.4	25.0	32.3	45.6	50	40.0	
•	•	<b>2360 XX</b>		14.7	20.8	29.4	36.0	46.5	65.7			

HOW TO MAKE UP THE NOZZLE CODE  
EX.: BVQ 1150 B1

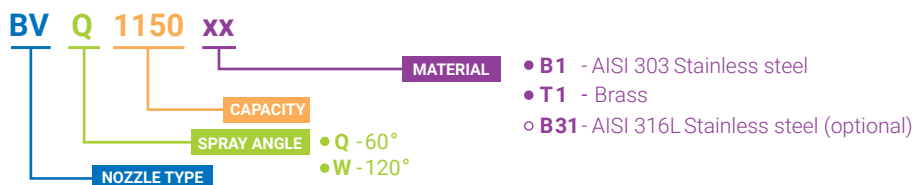

# BX / BJ ( FULL CONE NOZZLES / FLANGE )

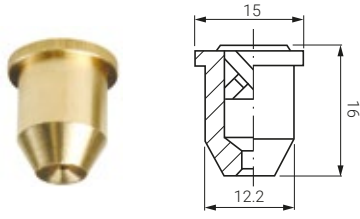

Outer shape of BX 1149 - BX 1372

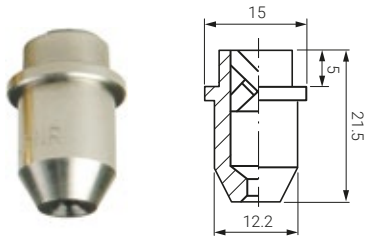

Outer shape of BX 1508 - BX 1743



### SAFETY FLANGE

In continuous casting cooling and other specific applications, nozzles are often positioned to spray upwards and must operate at very high temperatures. This may cause both thermal expansion and shrinkage of the nozzle vane due to temperature changes. The X-type vanes are designed to endure such temperature variations and to avoid the risk of escaping from the nozzle body in case of pump shut downs in vacuum conditions. All PNR full cone nozzles with X-vane (and thread size smaller than 3/8") have a protection flange to secure their vanes in place.

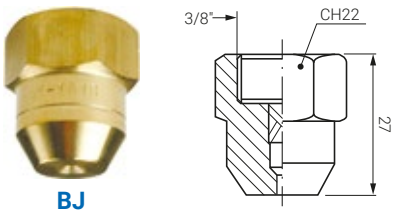

BJ

### ASSEMBLY ACCESSORIES

In most steelworks applications, BX series nozzles are provided with a welding nipple and locknut for the assembly of related accessories.

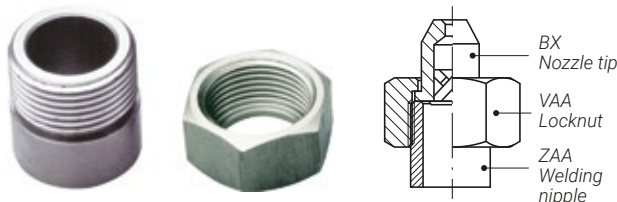

ZAA C018 xxG

VAA 0380 xx

### NOZZLE TIPS

BX full cone tips produce a uniform full cone shaped spray with a round impact area. Thanks to their design they can be easily disassembled and cleaned in case of clogging. These nozzles have an X-vane safely secured inside their body up to 3/8" thread size.

### TYPICAL APPLICATIONS

- Washing:* steel cleaning, parts cleaning, pre-treatment for coating process
- Cooling:* continuous casting cooling, product cooling, tank cooling
- Dust control:* dust removal in mining and coal plants
- Other applications:* spray of chemicals, leak test

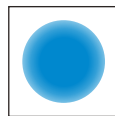

Spray section

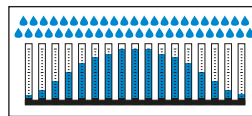

Convex distribution



CODE	D mm	Capacity at different pressure values (l/min) (bar)					Spray angle at pressure (°)			
		1.0	2.0	3.0	5.0	10	1.5	3.0	5.0	
60°	<b>BXQ 1149 xx</b>	1.3	0.86	1.22	1.49	1.92	2.72	50°	50°	45°
	<b>BXQ 1223 xx</b>	1.7	1.29	1.82	2.23	2.88	4.07	65°	65°	49°
	<b>BXQ 1262 xx</b>	1.7	1.51	2.14	2.62	3.38	4.78	50°	50°	46°
	<b>BXQ 1372 xx</b>	2.1	2.15	3.04	3.72	4.80	6.79	65°	65°	59°
	<b>BXQ 1508 xx</b>	2.4	2.93	4.15	5.08	6.56	9.27	50°	50°	46°
	<b>BXQ 1626 xx</b>	2.9	3.61	5.11	6.26	8.08	11.4	60°	60°	55°
	<b>BXQ 1743 xx</b>	2.9	4.29	6.07	7.43	9.59	13.6	67°	67°	61°

### SISTER PRODUCTS / THREAD SIZE

As for the BX series full cone nozzles, sister products with a 3/8" female thread are also available. In the steel industry spraying nozzles fixed on the water pipes can be easily damaged during the manufacturing process. PNR can offer the ideal solution to this problem, the BJ series nozzles designed according to customers' requirements. If welded tips are out of use, you can use BJ nozzles instead of BX. They have the same technical features and jet length.

Simply change the product code as follows, e.g.

**BXQ 1372 T1** → **BJQ 1372 T1**

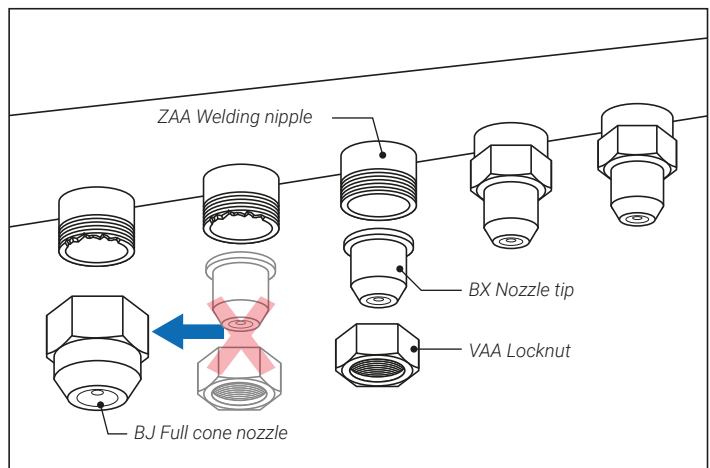

### HOW TO MAKE UP THE NOZZLE CODE

Ex.: BXQ 1149 B1

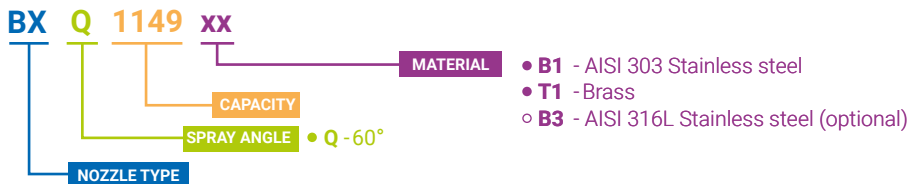

- B1 - AISI 303 Stainless steel
- T1 - Brass
- B3 - AISI 316L Stainless steel (optional)

( CLUSTER NOZZLE / 7 NOZZLES TYPE & 13 NOZZLES TYPE ) **CH**

CLUSTER NOZZLES / TYPE 7 AND 13

CH series includes large and small capacities hollow cone cluster nozzles. They make a cluster spray pattern and are available in 7 and 13 nozzles versions. Several nozzles are assembled on one nipple with small volume and wide spray coverage. The droplets size is 1/3-1/2 compared to those produced by a single nozzle with same capacity. An added value to CH nozzles is their wide spray range.



THREAD SPECIFICATION: BSP, NPT

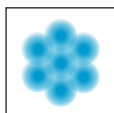

Spray section

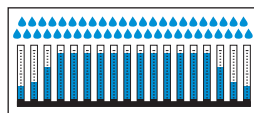

Even distribution

Spray Angle	CODE	RF inch	D inch	Capacity at different pressure values (l/min)					Dimensions mm				NR
				1.0	2.0	3.0	5.0	10	D	D1	H	H1	
									D	D1	H	H1	
200°	CHZ 1826 xx	3/4"	1/8"	4.77	6.47	8.26	10.7	15.1	71	40	55	13	7
	CHZ 2156 xx			9.01	12.7	15.6	20.1	28.5					
	CHZ 2329 xx	1"	1/4"	19.0	26.9	32.9	42.5	60.1	89	46	68	17	
	CHZ 2585 xx			33.8	47.8	58.5	75.5	106.8					
	CHZ 2819 xx			47.3	66.9	81.9	105.7	149.5					
	CHZ 3102 xx	1 1/2"	3/8"	59.4	84.0	102.9	132.8	187.9	128	70	93	20	
	CHZ 3131 xx			76.0	107.5	131.6	169.9	240.3					
360°	CHZ 3206 xx	2"	1/2"	119.2	168.6	206.5	266.6	377.0	171	85	122	27	
	CHZ 3259 xx		3/4"	149.5	211.5	259.0	334.4	472.9					
	CHZ 3329 xx			189.9	268.6	329.0	424.7	600.7					
	CHE 2153 xx	3/4"	1/8"	8.83	12.5	15.3	19.8	27.9	69	39	85	-	13
	CHE 2306 xx			17.7	25.0	30.6	39.5	55.9					
	CHE 2611 xx	1"	1/4"	35.3	49.9	61.1	78.9	111.6	86	48	105	-	
	CHE 3108 xx			62.7	88.7	108.6	140.2	198.3					
CHE 3152 xx			87.8	124.2	152.1	196.4	277.7						
CHE 3191 xx	1 1/2"	3/8"	110.3	156.0	191.1	246.7	348.9	98	55	120	-		
CHE 3245 xx			141.5	200.0	245.0	316.3	447.3						
CHE 3383 xx	2"	1/2"	221.4	313.1	383.5	495.1	700.2	129	73	158	-		
CHE 3481 xx		3/4"	277.7	392.7	481.0	621.0	878.2	169	95	206	-		

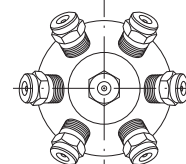
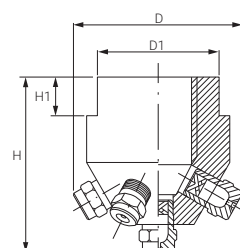

Cluster nozzle 7 nozzles type

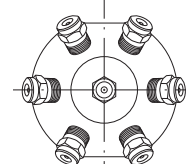
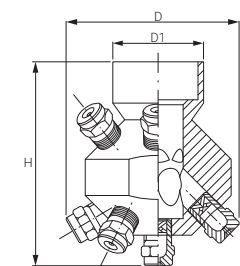

Cluster nozzle 13 nozzles type

\* We can supply other full cone nozzles in addition to the standard capacity. Please contact us.



TYPICAL APPLICATIONS

- Cooling: gas cooling
- Washing: tank cleaning, gas cleaning
- Other applications: fire engineering, dust control, wetting

HOW TO MAKE UP THE NOZZLE CODE  
Ex.: CHZ 1826 B1

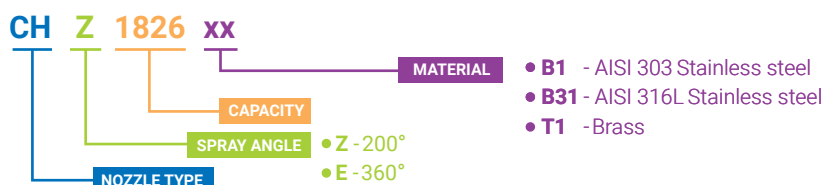



# CAS ( FULL CONE NOZZLES / CLUSTER NOZZLE )

## CLUSTER NOZZLE / STANDARD SPRAY ANGLE

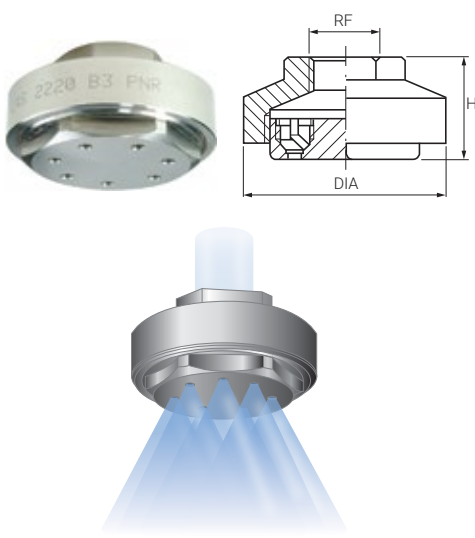

CAS cluster nozzles have seven orifices, large spray capacities and produce very fine droplets using hydraulic pressure only. As the droplets size, among other factors, also depends on the nozzle size, these multi-orifice nozzles produce a finer spray than a standard full cone single-orifice nozzle working at the same pressure and delivering the same quantity of liquid. They surely are the best choice when fine mist effect and large spray capacity are required.

THREAD SPECIFICATION: BSP, NPT

### TYPICAL APPLICATIONS

- Cooling:*  
cooling of high-temperature gas
- Fire control:*  
watermist fire suppression systems
- Other applications:*  
exhaust gas treatment, dust control, wetting

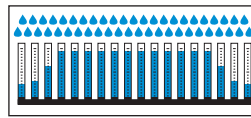
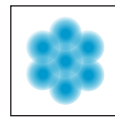

Spray section

Even distribution

70°	CODE	RF inch	D mm	D1 mm	Capacity at different pressure values (l/min) (bar)							Dimensions mm		
					0.7	1.0	1.5	2.0	3.0	5.0	10	NR	DIA	H
70°	CAS 1153 xx	1/2"	0.9	0.5	0.74	0.88	1.08	1.25	1.53	1.98	2.79	7	50	33.5
	CAS 1274 xx		1.8	0.5	1.32	1.58	1.94	2.24	2.74	3.54	5.00			
70°	CAS 1343 xx	3/4"	1.1	1.0	1.66	1.98	2.43	2.80	3.43	4.43	6.26	7	72	43
	CAS 1551 xx		1.5	1.4	2.66	3.18	3.90	4.50	5.51	7.11	10.1			
	CAS 1870 xx		2.1	2.0	4.20	5.02	6.15	7.10	8.70	11.2	15.9			
	CAS 2116 xx		2.5	2.0	5.60	6.70	8.20	9.47	11.6	15.0	21.2			
	CAS 2145 xx		3.0	2.0	7.00	8.37	10.3	11.8	14.5	18.7	26.5			
	CAS 2184 xx		3.5	2.0	8.89	10.6	13.0	15.0	18.4	23.8	33.6			
	CAS 2220 xx		4.0	2.0	10.6	12.7	15.6	18.0	22.0	28.4	40.2			
	CAS 2342 xx		3.5	2.0	16.5	19.7	24.2	27.9	34.2	44.2	62.4			
	CAS 2434 xx		4.0	2.0	21.0	25.1	30.7	35.4	43.4	56.0	79.2			
	CAS 2551 xx		5.0	2.0	26.6	31.8	39.0	45.0	55.1	71.1	101			
70°	CAS 2728 xx	1"	6.0	2.0	35.2	42.0	51.5	59.4	72.8	94.0	133	7	140	74
	CAS 2385 xx		5.0	2.5	18.6	22.2	27.2	31.4	38.5	49.7	70.3			
	CAS 2489 xx		6.5	2.5	23.6	28.2	34.6	39.9	48.9	63.1	89.3			
70°	CAS 2685 xx	2"	8.0	2.5	33.1	39.5	48.4	55.9	68.5	88.4	125	7	185	103
	CAS 3130 xx		9.0	5.0	62.8	75.1	91.9	106	130	168	237			
	CAS 3184 xx		12.0	5.0	88.9	106	130	150	184	238	336			
	CAS 3245 xx		15.0	5.0	118	141	173	200	245	316	447			

\* NR - Number of orifices

### HOW TO MAKE UP THE NOZZLE CODE

Ex.: CAS 1153 B31

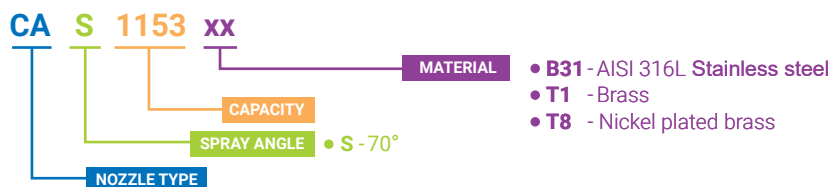

( FULL CONE NOZZLES / WIDE SPRAY ANGLE ) **CAY**

CLUSTER NOZZLE / WIDE SPRAY ANGLE

CAY cluster full cone nozzles produce very fine droplets using hydraulic pressure only. They provide large spray capacities, mist effect and a 130° spray angle with wider coverage. CAY nozzles have 7 orifices that, at the same operating pressure and using the same quantity of liquid, produce a finer spray than standard full cone nozzles with one orifice only. They are the best choice when large spray capacities and mist effect are required.

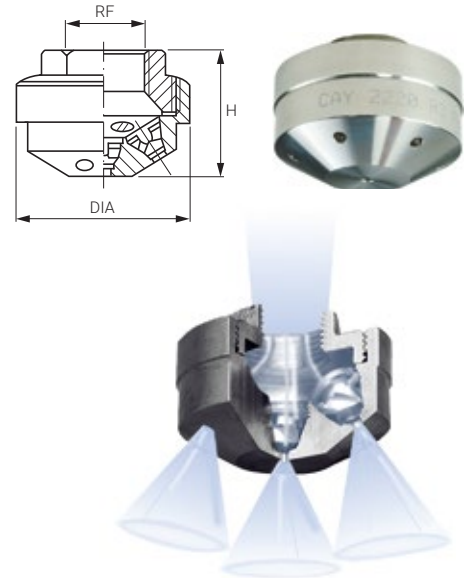

THREAD SPECIFICATION: BSP, NPT

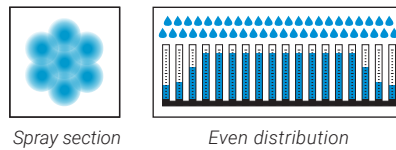

130°	CODE	RF inch	D mm	D1 mm	Capacity at different pressure values							Dimensions mm		
					0.7	1.0	1.5	2.0	3.0	5.0	10	NR	DIA	H
130°	<b>CAY 1153 xx</b>	1/2"	1.0	0.5			1.08	1.25	1.53	1.98	2.79	7	40	33.5
	<b>CAY 1274 xx</b>		1.8	0.5			1.94	2.24	2.74	3.54	5.00			
	<b>CAY 1343 xx</b>	3/4"	1.0	1.0	1.66	1.98	2.43	2.80	3.43	4.43	6.26	7	63	46.0
	<b>CAY 1551 xx</b>		1.4	1.4	2.66	3.18	3.90	4.50	5.51	7.11	10.1			
	<b>CAY 1870 xx</b>		2.0	2.0	4.20	5.02	6.15	7.10	8.70	11.2	15.9			
	<b>CAY 2116 xx</b>		2.5	2.0	5.60	6.70	8.20	9.47	11.6	15.0	21.2			
	<b>CAY 2145 xx</b>		3.0	2.0	7.00	8.37	10.3	11.8	14.5	18.7	26.5			
	<b>CAY 2184 xx</b>		3.5	2.0	8.89	10.6	13.0	15.0	18.4	23.8	33.6			
	<b>CAY 2220 xx</b>		4.0	2.0	10.6	12.7	15.6	18.0	22.0	28.4	40.2			
	<b>CAY 2342 xx</b>		3.5	1.7	16.5	19.7	24.2	27.9	34.2	44.2	62.4			
	<b>CAY 2434 xx</b>		4.0	1.7	21.0	25.1	30.7	35.4	43.4	56.0	79.2			
	<b>CAY 2551 xx</b>		5.0	1.7	26.6	31.8	39.0	45.0	55.1	71.1	101			
<b>CAY 2728 xx</b>	6.0	1.7	35.2	42.0	51.5	59.4	72.8	94.0	133					
130°	<b>CAY 2385 xx</b>	1"	5.0	3.2	18.6	22.2	27.2	31.4	38.5	49.7	70.3	7	120	81.0
	<b>CAY 2489 xx</b>		6.0	3.6	23.6	28.2	34.6	39.9	48.9	63.1	89.3			
	<b>CAY 2685 xx</b>		8.0	3.6	33.1	39.5	48.4	55.9	68.5	88.4	125			
	<b>CAY 2979 xx</b>		6.0	2.5	47.3	56.5	69.2	79.9	97.9	126	179			
	<b>CAY 3137 xx</b>		8.0	2.5	66.2	79.1	96.9	112	137	177	250			
130°	<b>CAY 3130 xx</b>	2"	9.0	3.2	62.8	75.1	91.9	106	130	168	237	7	155	104.5
	<b>CAY 3184 xx</b>		12.0	3.2	88.9	106	130	150	184	238	336			
	<b>CAY 3245 xx</b>		15.0	3.6	118	141	173	200	245	316	447			
	<b>CAY 3260 xx</b>		9.0	3.0	126	150	184	212	260	336	475			
	<b>CAY 3367 xx</b>		12.0	3.0	177	212	260	300	367	474	670			
	<b>CAY 3490 xx</b>		15.0	3.0	237	283	346	400	490	633	895			

\*NR - Number of orifices

TYPICAL APPLICATIONS

- Cooling: cooling of high-temperature gas
- Washing: tank cleaning, parts cleaning
- Fire control: water mist fire suppression systems
- Other applications: exhaust gas treatment, dust control, wetting

HOW TO MAKE UP THE NOZZLE CODE

Ex: CAY 1153 B1

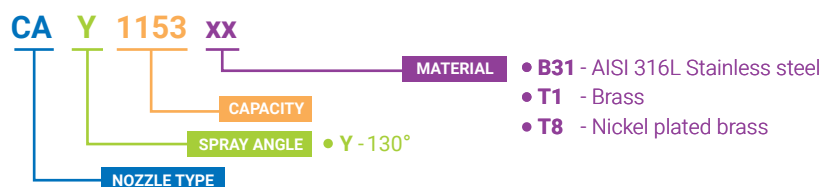

# D ( FULL CONE NOZZLES / STANDARD )

## X VANE / TWO-PIECE DESIGN

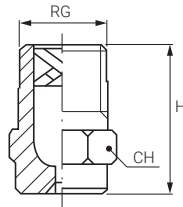

D series full cone nozzles with wide passage X-vanes offer a full choice of spray angles, capacities ranging from 1.18 and 1.420 l/min and connections from 1/8" to 4". In continuous casting cooling and other specific applications, they are used spraying upwards and operate at very high temperatures. The X-vane is safely locked into place for all dimensions up to 3/8", to avoid it may escape from the nozzle body in case of size changes due to temperature variations, and allows to assemble the nozzle with any desired orientation. Excellent mist effect and a wide variety of applications make D series nozzles an optimal choice.

THREAD SPECIFICATION: BSPT, NPT

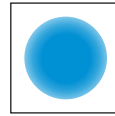

Spray section

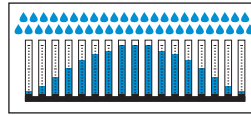

Convex distribution



### SPRAY ANGLE 45°

#### THREAD SIZE CODING TABLE

RG inch	Code	H mm	CH mm
1/8"	DA	19.5	12.0
1/4"	DB	22.0	14.0
3/8"	DC	25.0	17.0
1/2"	DD	33.0	22.0

#### HOW TO MAKE UP THE NOZZLE CODE

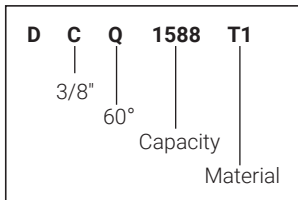

NOZZLE TYPE				CODE	D mm	D1 mm	Capacity (l/min) at different pressure values (bar)						
DAM	DBM	DCM	DDM				0.7	1.0	2.0	3.0	5.0	7.0	10
•							0740 xx	1.0	0.5	0.36	0.43	0.60	0.74
•	•			1118 xx	1.1	1.0	0.57	0.68	0.96	1.18	1.52	1.80	2.15
•	•			1147 xx	1.2	1.1	0.71	0.85	1.20	1.47	1.90	2.25	2.68
•	•			1188 xx	1.3	1.2	0.91	1.09	1.54	1.88	2.43	2.87	3.43
•	•			1212 xx	1.4	1.2	1.02	1.22	1.73	2.12	2.74	3.24	3.87
•	•	•		1235 xx	1.5	1.3	1.14	1.36	1.92	2.35	3.03	3.59	4.29
•	•	•		1294 xx	1.7	1.5	1.42	1.70	2.40	2.94	3.80	4.49	5.37
•	•	•		1370 xx	2.0	1.8	1.79	2.14	3.02	3.70	4.78	5.65	6.76
•	•	•	•	1470 xx	2.1	2.0	2.27	2.71	3.84	4.70	6.07	7.18	8.58
•	•	•	•	1588 xx	2.3	2.0	2.84	3.39	4.80	5.88	7.59	8.98	10.7
	•	•	•	1659 xx	2.5	2.2	3.18	3.80	5.38	6.59	8.51	10.1	12.0
		•	•	1740 xx	2.7	2.3	3.57	4.27	6.04	7.40	9.55	11.3	13.5
		•	•	1835 xx	2.8	2.6	4.03	4.82	6.82	8.35	10.8	12.8	15.2
		•	•	1940 xx	3.0	3.0	4.54	5.43	7.68	9.40	12.1	14.4	17.2
		•	•	2105 xx	3.2	3.2	5.07	6.06	8.57	10.5	13.6	16.0	19.2
		•	•	2117 xx	3.4	3.3	5.65	6.75	9.55	11.7	15.1	17.9	21.4
		•	•	2147 xx	3.8	3.7	7.10	8.49	12.0	14.7	19.0	22.5	26.8
		•	•	2188 xx	4.3	4.3	9.08	10.9	15.4	18.8	24.3	28.7	34.3
		•	•	2235 xx	5.0	4.5	11.4	13.6	19.2	23.5	30.3	35.9	42.9

### SPRAY ANGLE 60°

#### TYPICAL APPLICATIONS

##### Washing:

- Food cleaning
- Parts cleaning
- Pre-treatment for coating process

##### Cooling:

- Continuous casting cooling
- Product cooling
- Tank cooling

##### Dust control:

- Remove flying dust in mining and coal plants.

##### Other applications:

- Spray of chemicals
- Leak test

NOZZLE TYPE				CODE	D mm	D1 mm	Capacity (l/min) at different pressure values (bar)						
DAQ	DBQ	DCQ	DDQ				0.7	1.0	2.0	3.0	5.0	7.0	10
•							0740 xx	1.0	0.5	0.36	0.43	0.60	0.74
•	•			1118 xx	1.2	0.8	0.57	0.68	0.96	1.18	1.52	1.80	2.15
•	•			1147 xx	1.3	1.0	0.71	0.85	1.20	1.47	1.90	2.25	2.68
•	•	•		1188 xx	1.4	1.1	0.91	1.09	1.54	1.88	2.43	2.87	3.43
•	•	•		1212 xx	1.5	1.2	1.02	1.22	1.73	2.12	2.74	3.24	3.87
•	•	•		1235 xx	1.6	1.2	1.14	1.36	1.92	2.35	3.03	3.59	4.29
•	•	•		1294 xx	1.8	1.3	1.42	1.70	2.40	2.94	3.80	4.49	5.37
•	•	•		1370 xx	2.0	1.4	1.79	2.14	3.02	3.70	4.78	5.65	6.76
•	•	•		1470 xx	2.4	1.9	2.27	2.71	3.84	4.70	6.07	7.18	8.58
	•	•		1588 xx	2.6	2.0	2.84	3.39	4.80	5.88	7.59	8.98	10.7
	•	•		1659 xx	2.7	2.0	3.18	3.80	5.38	6.59	8.51	10.1	12.0
	•	•	•	1740 xx	2.9	2.0	3.57	4.27	6.04	7.40	9.55	11.3	13.5
	•	•	•	1835 xx	3.2	2.8	4.03	4.82	6.82	8.35	10.8	12.8	15.2
	•	•	•	1940 xx	3.2	2.8	4.54	5.43	7.68	9.40	12.1	14.4	17.2
	•	•	•	2105 xx	3.4	3.0	5.07	6.06	8.57	10.5	13.6	16.0	19.2
	•	•	•	2117 xx	3.6	3.0	5.65	6.75	9.55	11.7	15.1	17.9	21.4
		•	•	2147 xx	4.0	3.3	7.10	8.49	12.0	14.7	19.0	22.5	26.8
		•	•	2188 xx	4.5	3.7	9.08	10.9	15.4	18.8	24.3	28.7	34.3
		•	•	2235 xx	5.2	4.5	11.4	13.6	19.2	23.5	30.3	35.9	42.9
		•	•	2294 xx	5.8	4.7	14.2	17.0	24.0	29.4	38.0	44.9	53.7

( FULL CONE NOZZLES / STANDARD ) **D**

X VANE / TWO-PIECE DESIGN

SPRAY ANGLE 90°

NOZZLE TYPE				CODE	D mm	D1 mm	Capacity at different pressure values (l/min) (bar)						
DAU	DBU	DCU	DDU				0.7	1.0	2.0	3.0	5.0	7.0	10
•				0740 XX	1.0	0.5	0.36	0.43	0.60	0.74	0.96	1.13	1.35
•				1118 XX	1.2	0.8	0.57	0.68	0.96	1.18	1.52	1.80	2.15
•	•			1147 XX	1.3	1.0	0.71	0.85	1.20	1.47	1.90	2.25	2.68
•	•			1188 XX	1.4	1.2	0.91	1.09	1.54	1.88	2.43	2.87	3.43
•	•			1212 XX	1.5	1.2	1.02	1.22	1.73	2.12	2.74	3.24	3.87
•	•	•		1235 XX	1.6	1.3	1.14	1.36	1.92	2.35	3.03	3.59	4.29
•	•	•		1294 XX	1.8	1.3	1.42	1.70	2.40	2.94	3.80	4.49	5.37
•	•	•		1370 XX	2.0	1.4	1.79	2.14	3.02	3.70	4.78	5.65	6.76
	•	•		1470 XX	2.3	1.8	2.27	2.71	3.84	4.70	6.07	7.18	8.58
	•	•		1588 XX	2.6	1.8	2.84	3.39	4.80	5.88	7.59	8.98	10.7
	•	•		1659 XX	2.7	2.0	3.18	3.80	5.38	6.59	8.51	10.1	12.0
	•	•		1740 XX	2.9	2.0	3.57	4.27	6.04	7.40	9.55	11.3	13.5
	•	•		1835 XX	3.3	2.0	4.03	4.82	6.82	8.35	10.8	12.8	15.2
	•	•		1940 XX	3.3	2.4	4.54	5.43	7.68	9.40	12.1	14.4	17.2
	•	•		2105 XX	3.5	2.6	5.07	6.06	8.57	10.5	13.6	16.0	19.2
		•		2117 XX	3.7	2.7	5.65	6.75	9.55	11.7	15.1	17.9	21.4
		•		2147 XX	4.0	3.2	7.10	8.49	12.0	14.7	19.0	22.5	26.8
		•		2164 XX	4.1	3.2	7.92	9.47	13.4	16.4	21.2	25.1	29.9
			•	2188 XX	4.7	3.2	9.08	10.9	15.4	18.8	24.3	28.7	34.3
			•	2235 XX	5.2	3.8	11.4	13.6	19.2	23.5	30.3	35.9	42.9
			•	2294 XX	5.8	3.8	14.2	17.0	24.0	29.4	38.0	44.9	53.7
			•	2370 XX	6.4	3.8	17.9	21.4	30.2	37.0	47.8	56.5	67.6

X- VANE

X vanes are widely used, mainly in steelworks. Their simple design is based on two sloping flat surfaces which induce a rotation of the liquid going through the nozzle, and two small slots on each flat part to produce a full-cone spray pattern.

All vanes are secured inside the nozzle body to prevent their moving in case of size changes due to high temperatures or sudden vacuum conditions in the feed pipe.

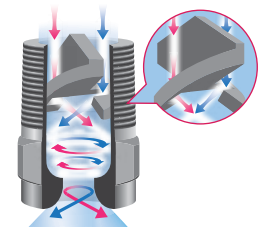

SPRAY ANGLE 120°

NOZZLE TYPE				CODE	D mm	D1 mm	Capacity at different pressure values (l/min) (bar)						
DAW	DBW	DCW	DDW				0.7	1.0	2.0	3.0	5.0	7.0	10
•				0740 XX	1.0	0.5	0.36	0.43	0.60	0.74	0.96	1.13	1.35
•	•			1118 XX	1.2	0.8	0.57	0.68	0.96	1.18	1.52	1.80	2.15
•	•			1147 XX	1.3	0.9	0.71	0.85	1.20	1.47	1.90	2.25	2.68
•	•			1188 XX	1.5	1.0	0.91	1.09	1.54	1.88	2.43	2.87	3.43
•	•			1212 XX	1.6	1.1	1.02	1.22	1.73	2.12	2.74	3.24	3.87
•	•	•		1235 XX	1.6	1.2	1.14	1.36	1.92	2.35	3.03	3.59	4.29
•	•	•		1294 XX	1.9	1.3	1.42	1.70	2.40	2.94	3.80	4.49	5.37
•	•	•		1370 XX	2.1	1.4	1.79	2.14	3.02	3.70	4.78	5.65	6.76
	•	•		1470 XX	2.4	1.6	2.27	2.71	3.84	4.70	6.07	7.18	8.58
	•	•		1588 XX	2.7	1.8	2.84	3.39	4.80	5.88	7.59	8.98	10.7
	•	•		1659 XX	3.0	1.8	3.18	3.80	5.38	6.59	8.51	10.1	12.0
	•	•		1740 XX	3.1	1.9	3.57	4.27	6.04	7.40	9.55	11.3	13.5
	•	•		1835 XX	3.3	1.9	4.03	4.82	6.82	8.35	10.8	12.8	15.2
	•	•		1940 XX	3.5	1.9	4.54	5.43	7.68	9.40	12.1	14.4	17.2
	•	•		2105 XX	3.7	2.3	5.07	6.06	8.57	10.5	13.6	16.0	19.2
		•	•	2117 XX	3.8	2.4	5.65	6.75	9.55	11.7	15.1	17.9	21.4
		•	•	2147 XX	4.2	2.7	7.10	8.49	12.0	14.7	19.0	22.5	26.8
		•	•	2164 XX	4.4	2.7	7.92	9.47	13.4	16.4	21.2	25.1	29.9
		•	•	2188 XX	4.6	3.1	9.08	10.9	15.4	18.8	24.3	28.7	34.3
		•	•	2235 XX	5.3	3.3	11.4	13.6	19.2	23.5	30.3	35.9	42.9
		•	•	2294 XX	5.9	4.1	14.2	17.0	24.0	29.4	38.0	44.9	53.7
		•	•	2370 XX	6.6	4.7	17.9	21.4	30.2	37.0	47.8	56.5	67.6



HOW TO MAKE UP THE NOZZLE CODE

Ex.: DAU 1118 B1

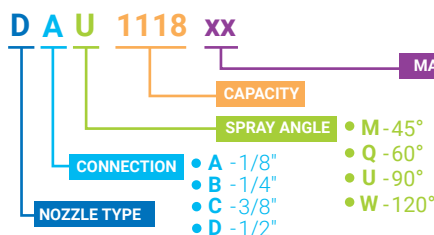

- B1 - AISI 303 Stainless steel
- B31 - AISI 316L Stainless steel
- T1 - Brass
- Other materials on request

# D ( FULL CONE NOZZLES / STANDARD / LARGE CAPACITY )

## X-VANE / TWO-PIECE DESIGN / LARGE CAPACITY

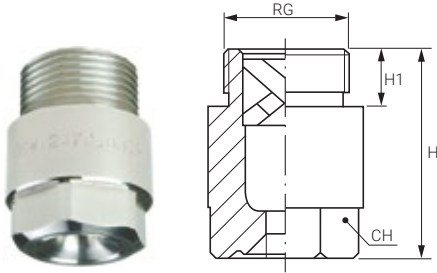

D series full cone nozzles with large capacity are widely used in industry. They provide uniform spray coverage and are available in various thread sizes, spray angles and capacities to comply with environmental requirements. Their X-vane offers the largest free passage available in a nozzle, for an easier handling of the suspended particles and a higher resistance to clogging. D nozzles provide an optimal mist effect and are effective in many industrial applications.

THREAD SPECIFICATION:  
BSPT, NPT (on request)

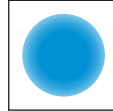

Spray section

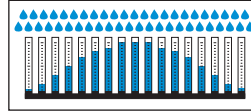

Convex distribution



60°	CODE	RG inch	D mm	D1 mm	Capacity at different pressure values (l/min) (bar)						Dimensions mm			
					0.7	1.0	2.0	3.0	5.0	7.0	10	H	H1	CH
60°	DEQ 2235 xx	3/4"	4.8	3.5	11.4	13.6	19.2	23.5	30.3	35.9	42.9	43	16	27
	DEQ 2295 xx		5.5	4.5	14.2	17.0	24.1	29.5	38.1	45.1	53.9			
	DEQ 2370 xx		6.0	4.5	17.9	21.4	30.2	37.0	47.8	56.5	67.6			
	DEQ 2470 xx		7.0	4.5	22.7	27.1	38.4	47.0	60.7	71.8	85.8			
	DFQ 2470 xx	1"	7.0	5.6	22.7	27.1	38.4	47.0	60.7	71.8	85.8	58	18	36
	DFQ 2590 xx		7.8	5.6	28.5	34.1	48.2	59.0	76.2	90.1	108			
	DFQ 2740 xx		9.5	5.6	35.7	42.7	60.4	74.0	95.5	113	135			
	DGQ 2740 xx	1 1/4"	9.5	5.6	35.7	42.7	60.4	74.0	95.5	113	135	74	19	41
	DGQ 3118 xx		12.5	6.0	57.0	68.1	96.3	118	152	180	215			
	DGQ 3147 xx		16.7	6.0	71.0	84.9	120	147	190	225	268			
	DHQ 3147 xx	1 1/2"	13.0	9.0	71.0	84.9	120	147	190	225	268	85	19	50
	DKQ 3188 xx	2"	15.0	9.0	90.8	109	154	188	243	287	343	106	24	60
	DKQ 3235 xx		16.0	11.0	114	136	192	235	303	359	429			
	DKQ 3294 xx		17.0	11.1	142	170	240	294	380	449	537			
	DLQ 3370 xx	2 1/2"	17.5	11.1	179	214	302	370	478	565	676	128	27	75
	DLQ 3470 xx		23.0	11.1	227	271	384	470	607	718	858			
	DMQ 3588 xx	3"	28.0	14.3	284	339	480	588	759	898	1074	153	30	85
	DNQ 3740 xx	3 1/2"	29.0	17.5	357	427	604	740	955	1130	1351	190	32	105
DNQ 3940 xx	36.0		17.5	454	543	768	940	1214	1436	1716				
DPQ 4117 xx	4"	39.0	19.0	568	678	959	1175	1517	1795	2145	205	36	110	

90°	CODE	RG inch	D mm	D1 mm	Capacity at different pressure values (l/min) (bar)						Dimensions mm			
					0.7	1.0	2.0	3.0	5.0	7.0	10	H	H1	CH
90°	DEU 2295 xx	3/4"	5.8	3.0	14.2	17.0	24.1	29.5	38.1	45.1	53.9	43	16	27
	DEU 2370 xx		6.4	4.5	17.9	21.4	30.2	37.0	47.8	56.5	67.6			
	DEU 2470 xx		8.0	4.5	22.7	27.1	38.4	47.0	60.7	71.8	85.8			
	DEU 2590 xx		9.7	4.5	28.5	34.1	48.2	59.0	76.2	90.1	108			
	DFU 2590 xx	1"	8.6	4.5	28.5	34.1	48.2	59.0	76.2	90.1	108	58	18	36
	DFU 2740 xx		9.3	5.0	35.7	42.7	60.4	74.0	95.5	113	135			
	DFU 2830 xx		9.9	6.0	40.3	48.2	68.2	83.5	108	128	152			
	DGU 3118 xx	1 1/4"	13.0	6.0	57.0	68.1	96.3	118	152	180	215	74	19	41
	DGU 3147 xx		16.0	6.0	71.0	84.9	120	147	190	225	268			
	DHU 3147 xx	1 1/2"	16.0	6.0	71.0	84.9	120	147	190	225	268	85	19	50
	DHU 3188 xx		14.5	9.0	90.8	109	154	188	243	287	343			
	DKU 3235 xx	2"	16.6	11.0	114	136	192	235	303	359	429	106	24	60
	DKU 3294 xx		18.0	11.0	142	170	240	294	380	449	537			
	DKU 3370 xx		25.0	11.0	179	214	302	370	478	565	676			
	DLU 3470 xx	2 1/2"	27.0	11.1	227	271	384	470	607	718	858	128	27	75
	DLU 3588 xx		30.0	14.3	284	339	480	588	759	898	1074			
	DMU 3740 xx	3"	30.0	17.5	357	427	604	740	955	1130	1351	153	30	85
	DMU 3870 xx		32.5	17.5	420	502	710	870	1123	1329	1588			
	DNU 3940 xx	3 1/2"	35.5	17.5	454	543	768	940	1214	1436	1716	190	32	105
	DNU 4117 xx		39.0	19.0	568	678	959	1175	1517	1795	2145			
	DPU 4147 xx	4"	42.8	25.4	710	849	1200	1470	1898	2245	2684	205	36	110



( FULL CONE NOZZLES / STANDARD / LARGE CAPACITY ) **D**

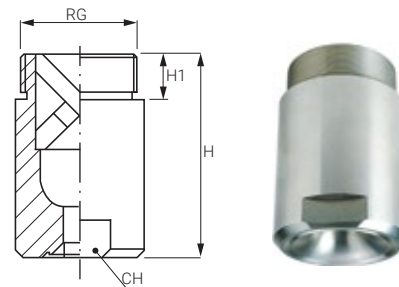

120°	CODE	RG inch	D mm	D1 mm	Capacity at different pressure values (l/min) (bar)								Dimensions mm		
					0.7	1.0	2.0	3.0	5.0	7.0	10	H	H1	CH	
120°	<b>DE W 2295 xx</b>	3/4"	5.1	3.0	14.2	17.0	24.1	29.5	38.1	45.1	53.9	43	16	27	
	<b>DE W 2370 xx</b>		6.5	3.5	17.9	21.4	30.2	37.0	47.8	56.5	67.6				
	<b>DE W 2470 xx</b>		8.5	4.5	22.7	27.1	38.4	47.0	60.7	71.8	85.8				
	<b>DE W 2590 xx</b>		9.2	4.5	28.5	34.1	48.2	59.0	76.2	90.1	108				
	<b>DF W 2590 xx</b>	1"	11.5	4.5	28.5	34.1	48.2	59.0	76.2	90.1	108	58	18	36	
	<b>DF W 2740 xx</b>		12.0	4.5	35.7	42.7	60.4	74.0	95.5	113	135				
	<b>DF W 2830 xx</b>		13.0	5.6	40.3	48.2	68.2	83.5	108	128	152				
	<b>DGW 3118 xx</b>	1 1/4"	13.5	6.0	57.0	68.1	96.3	118	152	180	215	74	19	41	
	<b>DGW 3147 xx</b>		17.0	6.0	71.0	84.9	120	147	190	225	268				
	<b>DHW 3118 xx</b>	1 1/2"	13.0	6.0	57.0	68.1	96.3	118	152	180	215	85	19	50	
	<b>DHW 3188 xx</b>		20.0	9.0	90.8	109	154	188	243	287	343				
	<b>DK W 3235 xx</b>	2"	18.0	11.0	114	136	192	235	303	359	429	106	24	60	
	<b>DK W 3294 xx</b>		19.0	11.0	142	170	240	294	380	449	537				
	<b>DK W 3370 xx</b>		21.3	11.0	179	214	302	370	478	565	676				
	<b>DL W 3470 xx</b>	2 1/2"	23.5	11.1	227	271	384	470	607	718	858	128	27	75	
	<b>DL W 3588 xx</b>		26.5	14.3	284	339	480	588	759	898	1074				
	<b>DMW 3740 xx</b>	3"	29.5	17.5	357	427	604	740	955	1130	1351	153	30	85	
	<b>DMW 3870 xx</b>		32.0	17.5	420	502	710	870	1123	1329	1588				
<b>DN W 3940 xx</b>	3 1/2"	33.5	17.5	454	543	768	940	1214	1436	1716	190	32	105		
<b>DN W 4117 xx</b>		37.0	19.0	568	678	959	1175	1517	1795	2145					
<b>DP W 4147 xx</b>	4"	42.0	25.4	710	849	1200	1470	1898	2245	2684	205	36	110		

THREAD SIZE CODE (RG)

DE	DF	DG	DH	DK	DL	DM	DN	DP
3/4"	1"	1 1/4"	1 1/2"	2"	2 1/2"	3"	3 1/2"	4"

TYPICAL APPLICATIONS

*Washing:* food cleaning, parts cleaning, pre-treatment for coating process

*Cooling:* continuous casting cooling, product cooling, tank cooling

*Dust control:* dust suppression in mining and coal plants.

*Other applications:* spray of chemicals, leak test.

HOW TO MAKE UP THE NOZZLE CODE

Ex.: DEQ 2235 B1

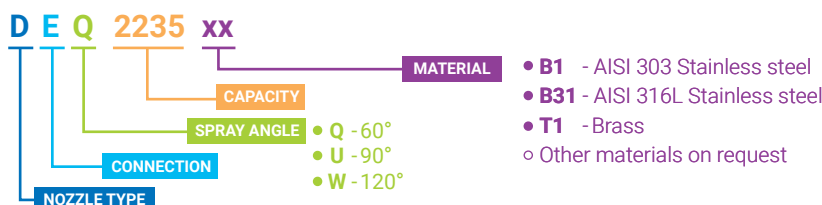

# Dplus (CONSTANT SPRAY ANGLE / UNIFORM DISTRIBUTION / ANTI-OCCLUSION)

## SPECIAL PATENTED VORTICATOR

Dplus series nozzle tips provide a full cone jet with a characteristic spray angle which is independent from the pressure input in a range from 1 bar to 10 bar. Spray distribution is perfectly balanced and symmetric with a very uniform coverage of the circular impact area.

The wide internal passages prevents nozzle clogging even from large particles, while the internal controlled turbulence keep its performance stable and reliable over the all working pressure range. The large passages guarantees low local velocities meaning a high wear resistance. Dplus series full cone jet nozzles are available in a wide range of different capacities, spray angles and materials.

THREAD SPECIFICATIONS: BSPT, NPT

### TYPICAL APPLICATIONS

- Steel
- Chemical processes
- Spray cooling

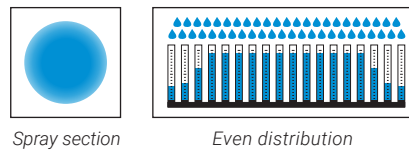
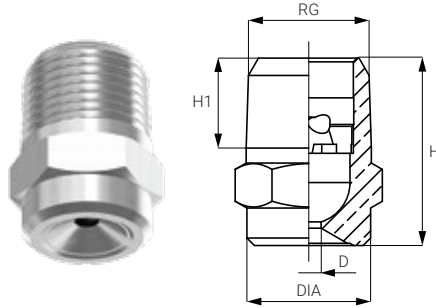

### STANDARD CAPACITY

CODE D1	D mm	D1 mm Minimun free passage	Capacity at different pressure values (l/min) (bar)							Dimensions mm				
			1.0	2.0	3.0	4.0	5.0	7.0	10	H	H1	DIA	WS	RG
1118	1.2	1.2	0.66	0.96	1.18	1.4	1.58	2	2.4	18	9	10	12	1/8" BSPT
1147	1.4	1.4	0.9	1.2	1.47	1.8	2.1	2.75	3.7					
1188	1.8	1.8	1.2	1.5	1.88	2.2	2.6	3.4	4					
1212	1.9	1.8	1.22	1.7	2.12	2.44	2.7	3.23	3.87					
1235	2	1.8	1.43	2.15	2.35	2.7	3.15	3.52	4.1	18	9	10	12	1/8" NPT
1294	2.1	2	2.3	2.7	2.94	3.4	3.7	4.3	5.2					
1370	2.2	2	2.1	2.8	3.7	4	4.3	5	5.8					
1470	2.3	2	2.7	3.8	4.7	5.4	6	7.18	8.6					

CODE D2	D mm	D1 mm Minimun free passage	Capacity at different pressure values (l/min) (bar)							Dimensions mm				
			1.0	2.0	3.0	4.0	5.0	7.0	10	H	H1	DIA	WS	RG
1147	1.4	1.4	0.9	1.2	1.47	1.8	2.1	2.75	3.7	22,5	12,5	13,5	14	1/4" BSPT
1188	1.8	1.8	1.2	1.5	1.88	2.2	2.6	3.4	4					
1212	1.9	1.9	1.22	1.7	2.12	2.44	2.7	3.23	3.87					
1235	2	2	1.43	2.15	2.35	2.7	3.15	3.52	4.1					
1294	2.1	2.1	2.3	2.7	2.94	3.4	3.7	4.3	5.2					
1370	2.2	2.2	2.1	2.8	3.7	4	4.3	5	5.8					
1470	2.5	2.5	3	3.9	4.7	5.2	5.8	6.8	7.5					
1588	2.8	2.8	3.4	5	5.88	6.6	7.2	8.2	9.5					
1659	3.3	3	3.8	5.4	6.59	7.6	8.5	10	12					
1740	3.5	3.5	4.3	6	7.4	8.54	9.55	11.3	13.5					
1940	3.8	3.5	5.4	7.7	9.4	10.8	12.1	14.3	17.2					

### THREAD SIZE CODE (RG)

D1	D2	D3	D4	D5	D6	D7	D8
1/8"	1/4"	3/8"	1/2"	1"	1 1/2"	2"	3"

( CONSTANT SPRAY ANGLE / UNIFORM DISTRIBUTION / ANTI-OCCCLUSION ) **Dplus**

STANDARD CAPACITY

CODICE D3	D mm	D1 mm Minimum free passage	Capacity at different pressure values							Dimensions mm				
			1.0	2.0	3.0	4.0	5.0	7.0	10	H	H1	DIA	WS	RG
1235	1.8	2	1.43	2.15	2.35	2.7	3.15	3.52	4.1	24,5	12	16,5	17	3/8" BSPT
1294	2	2	2.3	2.7	2.94	3.4	3.7	4.3	5.2					
1370	2.2	2	2.1	2.8	3.7	4	4.3	5	5.8					
1470	2.4	2.4	3	3.9	4.7	5.2	5.8	6.8	7.5					
1588	2.8	2.8	3.4	5	5.88	6.6	7.2	8.2	9.5					
1659	3.1	3	3.8	5.4	6.59	7.6	8.5	10	12					
1740	3.4	3.4	4.3	6	7.4	8.54	9.55	11.3	13.5					
1940	3.6	3.5	5.4	7.7	9.4	10.8	12.1	14.3	17.2					
2105	3.8	3.5	6.1	8.57	10.5	12.1	13.5	16	19.1					
2118	4	4	6.8	9.6	11.8	13.6	15.2	18	21.5					
2147	4.4	4	8.5	12	14.7	16.9	18.9	22.4	26.8					
2188	4.6	4.5	10.8	15.3	18.8	21.7	24.3	28.7	34.3					

CODICE D4	D mm	D1 mm Minimum free passage	Capacity at different pressure values							Dimensions mm				
			1.0	2.0	3.0	4.0	5.0	7.0	10	H	H1	DIA	WS	RG
1740	3.4	3.4	4.3	6	7.4	8.54	9.55	9.55	13.5	33	18	21,5	22	1/2" BSPT
1940	3.6	3.5	5.4	7.7	9.4	10.8	12.1	12.1	17.2					
2105	3.8	4	6.1	8.57	10.5	12.1	13.5	13.5	19.1					
2118	4	4	6.8	9.6	11.8	13.6	15.2	15.2	21.5					
2147	4.4	4.5	8.5	12	14.7	16.9	18.9	18.9	26.8					
2188	4.6	4.5	10.8	15.3	18.8	21.7	24.3	24.3	34.3					
2235	5	5	13.5	19.1	23.5	27.1	30.3	30.3	42.9					
2294	5.2	5	16.9	24	29.4	33.9	37.9	37.9	53.7					

SPRAY ANGLE AT DIFFERENT PRESSURE

(D3Q example chart)

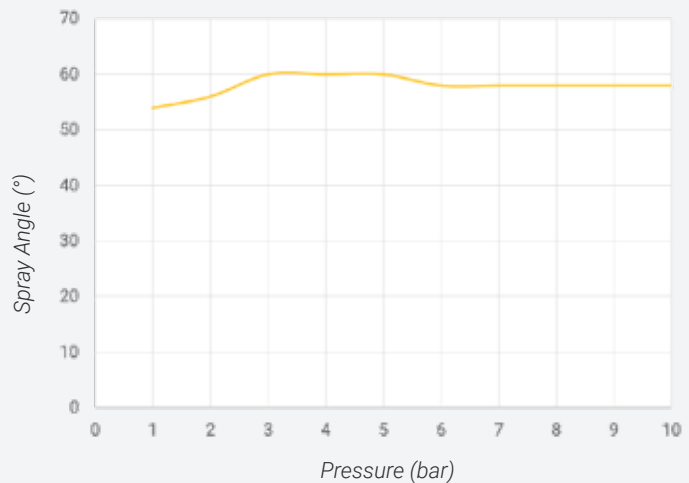

HOW TO MAKE UP THE NOZZLE CODE

EX.: D1Q 1235 B31 SB

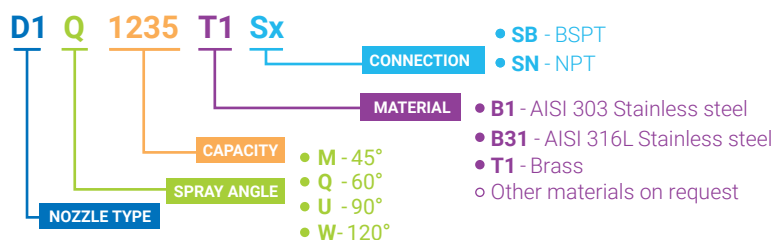

# E (FULL CONE NOZZLES / STANDARD SPIRAL NOZZLES)

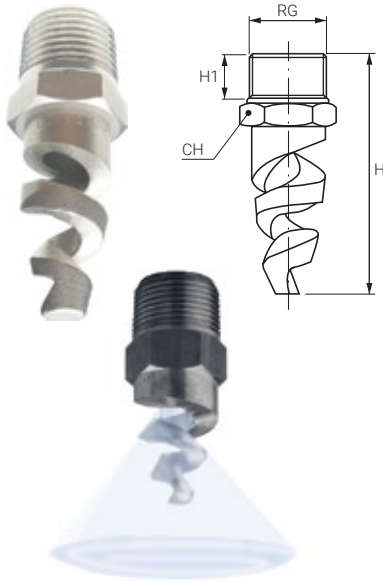

## STANDARD SPIRAL NOZZLES

E series spiral nozzles work on the impact principle, by the deflection of a water stream that impacts onto a spiral profiled surface which provides the desired spray angle. These are one-piece nozzles with no internal vane and a wider free passage. The liquid inlet has nearly the same size as the outlet orifice diameter. Their special design makes them virtually clog-free and produces a wider spray coverage than other nozzles for a given flow and pressure. The capacity values on darker background can be obtained with metal nozzles only, plastic materials being too weak to assure structural nozzle resistance in harsh operating conditions. If the capacity values you are looking for are those on darker background, we recommend to choose metal nozzles for their longer operating life.

THREAD SPECIFICATION: BSPT, NPT



Spray section

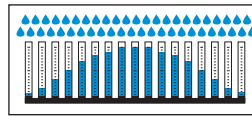

Convex distribution



### TYPICAL APPLICATIONS

- Gas cooling
- Exhaust scrubbers
- Desulfurization
- Cooling
- Other applications
- Spray of chemicals
- Fire prevention and fire suppression

60°	CODE	RG inch	D mm	D1 mm	Capacity at different pressure values (l/min) (bar)							Dimensions mm		
					0.7	1.0	2.0	3.0	5.0	7.0	10	H	H1	CH
60°	<b>EBQ 1550 xx</b>	1/4"	2.4	2.4	2.66	3.18	4.49	5.50	7.10	8.40	10.0	45	12	14
	<b>EBQ 2156 xx</b>		4.0	3.2	7.54	9.01	12.7	15.6	20.1	23.8	28.5			
	<b>ECQ 2230 xx</b>	3/8"	4.8	3.2	11.4	13.6	19.2	23.5	30.3	35.9	42.9	48	14	19
	<b>ECQ 2410 xx</b>		6.4	3.2	20.0	24.0	33.9	41.5	53.6	63.4	75.8			
	<b>ECQ 2640 xx</b>		7.9	3.2	31.2	37.3	52.7	64.6	83.4	99.0	118			
	<b>EDQ 2940 xx</b>	1/2"	9.5	4.7	45.6	54.5	77.1	94.4	122	144	172	64	18	22
	<b>EDQ 3128 xx</b>		11.1	4.7	61.8	73.9	105	128	165	196	234			
	<b>EEQ 3165 xx</b>	3/4"	12.7	4.7	79.7	95.3	135	165	213	252	301	70	19	27
	<b>EFQ 3260 xx</b>	1"	15.9	6.3	126	150	212	260	336	397	475	92	26	34
<b>EFQ 3372 xx</b>		19.0	6.3	180	215	304	372	480	568	679				
<b>EHQ 3507 xx</b>	1 1/2"	22.2	7.9	245	293	414	507	655	774	926	111	27	50	
<b>EKQ 4109 xx</b>	2"	34.9	11.1	527	629	890	1090	1407	1665	1990	149	31	65	
90°	<b>EBU 1550 xx</b>	1/4"	2.4	2.4	2.66	3.18	4.49	5.50	7.10	8.40	10.0	45	12	14
	<b>EBU 2100 xx</b>		3.2	3.2	4.83	5.77	8.16	10.0	12.9	15.3	18.3			
	<b>EBU 2156 xx</b>		4.0	3.2	7.54	9.01	12.7	15.6	20.1	23.8	28.5			
	<b>ECU 2230 xx</b>	3/8"	4.8	3.2	11.4	13.6	19.2	23.5	30.3	35.9	42.9	48	14	19
	<b>ECU 2317 xx</b>		5.6	3.9	15.3	18.3	25.9	31.7	40.9	48.4	57.9			
	<b>ECU 2410 xx</b>		6.4	4.8	20.0	24.0	33.9	41.5	53.6	63.4	75.8			
	<b>ECU 2640 xx</b>		7.9	5.5	31.2	37.3	52.7	64.6	83.4	98.7	118			
	<b>EDU 2940 xx</b>	1/2"	9.5	3.3	45.6	54.5	77.1	94.4	122	144	172	64	18	22
	<b>EDU 3128 xx</b>		11.1	3.7	61.8	73.9	105	128	165	196	234			
	<b>EEU 3165 xx</b>	3/4"	12.7	4.7	79.7	95.3	135	165	213	252	301	70	19	27
	<b>EFU 3260 xx</b>	1"	19.0	6.3	126	150	212	260	336	397	475	92	26	34
	<b>EFU 3372 xx</b>		23.0	6.3	180	215	304	372	480	568	679			
	<b>EK U 4109 xx</b>	2"	34.9	11.1	527	629	890	1090	1407	1665	1990	149	31	65
	<b>EMU 4204 xx</b>	3"	44.5	14.3	985	1178	1666	2040	2634	3116	3725	219	42	89
	<b>EMU 4267 xx</b>		50.8		1290	1542	2180	2670	3447	4078	4875			

### THREAD SIZE CODE (RG)

EB	EC	ED	EE	EF	EH	EK	EM	EP
1/4"	3/8"	1/2"	3/4"	1"	1 1/2"	2"	3"	4"

### SPIRAL NOZZLES

The picture shows the inside of a spiral nozzle with a complete free passage without any internal vane. It has nearly the same size of liquid inlet and outlet orifice diameter to avoid clogging.



### HOW TO MAKE UP THE NOZZLE CODE

EX.: EBQ 1550 B31

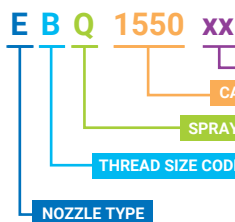

- B31 - AISI 316L Stainless Steel
- T1 - Brass
- D1 - PVC
- D2 - PP
- D8 - PVDF
- E1 - PTFE
- L61 - Hastelloy C22
- Special materials are quoted on request

( FULL CONE NOZZLES / STANDARD SPIRAL NOZZLES )

E

STANDARD SPIRAL NOZZLES

	CODE	RG inch	D mm	D1 mm	Capacity at different pressure values						(l/min) (bar)	Dimensions mm		
					0.7	1.0	2.0	3.0	5.0	7.0		10	H	H1
120°	<b>EBW 1550 xx</b>	1/4"	2.4	2.4	2.66	3.18	4.49	5.50	7.10	8.40	10.0	45	12	14
	<b>EBW 2100 xx</b>		3.2	3.2	4.83	5.77	8.16	10.0	12.9	15.3	18.3			
	<b>EBW 2156 xx</b>		4.0	3.2	7.54	9.01	12.7	15.6	20.1	23.8	28.5			
	<b>ECW 2156 xx</b>	3/8"	4.0	3.2	7.54	9.01	12.7	15.6	20.1	23.8	28.5	48	14	19
	<b>ECW 2230 xx</b>		4.8	3.2	11.4	13.6	19.2	23.5	30.3	35.9	42.9			
	<b>ECW 2317 xx</b>		5.6	4.0	15.3	18.3	25.9	31.7	40.9	48.4	57.9			
	<b>ECW 2410 xx</b>		6.4	4.0	20.0	24.0	33.9	41.5	53.6	63.4	75.8			
	<b>ECW 2640 xx</b>		7.9	4.0	31.2	37.3	52.7	64.6	83.4	98.7	118			
	<b>EDW 2940 xx</b>	1/2"	9.5	4.8	45.6	54.5	77.1	94.4	122	144	172	64	18	22
	<b>EDW 3104 xx</b>		9.7	4.8	50.2	60.0	84.9	104	134	159	190			
	<b>EDW 3128 xx</b>		11.1	4.8	61.8	73.9	105	128	165	196	234			
	<b>EEW 3165 xx</b>	3/4"	12.7	4.8	79.7	95.3	135	165	213	252	301	70	19	27
	<b>EFW 3260 xx</b>	1"	15.9	6.3	126	150	212	260	336	397	475	92	26	34
	<b>EFW 3372 xx</b>		19.0		180	215	304	372	480	568	679			
	<b>EHW 3507 xx</b>	1 1/2"	22.2	7.9	245	293	414	507	655	774	926	111	27	50
	<b>EHW 3663 xx</b>		25.4		320	383	541	663	856	1013	1210			
	<b>EHW 3747 xx</b>		28.6		361	431	610	747	964	1141	1364			
	<b>EKW 4109 xx</b>	2"	34.9	11.1	527	629	890	1090	1407	1665	1990	149	31	65
<b>EKW 4139 xx</b>		38.1		672	803	1136	1391	1796	2125	2540				
<b>EMW 4204 xx</b>	3"	44.5	14.3	985	1178	1666	2040	2634	3116	3725	203	35	90	
<b>EMW 4265 xx</b>		51.0		1280	1530	2164	2650	3421	4048	4838				
<b>EPW 4412 xx</b>	4"	63.5	15.9	1990	2379	3364	4120	5319	6293	7522	230	40	127	
150°	<b>ECX 2230 xx</b>	3/8"	4.8	3.2	11.4	13.6	19.2	23.5	30.3	35.9	42.9	48	14	19
	<b>ECX 2317 xx</b>		5.6	4.0	15.3	18.3	25.9	31.7	40.9	48.4	57.9			
	<b>ECX 2410 xx</b>		6.4		20.0	24.0	33.9	41.5	53.6	63.4	75.8			
	<b>ECX 2640 xx</b>		7.9		31.2	37.3	52.7	64.6	83.4	98.7	118			
	<b>EDX 2940 xx</b>	1/2"	9.5	4.8	45.6	54.5	77.1	94.4	122	144	172	64	18	22
	<b>EDX 3128 xx</b>		11.1		61.8	73.9	105	128	165	196	234			
	<b>EEX 3165 xx</b>	3/4"	12.7	4.8	79.7	95.3	135	165	213	252	301	70	19	27
	<b>EFX 3260 xx</b>	1"	15.9	6.3	126	150	212	260	336	397	475	92	26	34
	<b>EFX 3372 xx</b>		19.0		180	215	304	372	480	568	679			
	<b>EHX 3507 xx</b>	1 1/2"	22.2	7.9	245	293	414	507	655	774	926	111	27	50
	<b>EHX 3663 xx</b>		25.4		320	383	541	663	856	1013	1210			
	<b>EHX 3747 xx</b>		28.6		361	431	610	747	964	1141	1364			
<b>EKX 4109 xx</b>	2"	34.9	11.1	527	629	890	1090	1407	1665	1990	149	31	65	
<b>EKX 4139 xx</b>		38.1		672	803	1136	1391	1796	2125	2540				
180°	<b>EBZ 2156 xx</b>	1/4"	4.0	2.5	7.54	9.01	12.7	15.6	20.1	23.8	28.5	45	12	14
	<b>ECZ 2230 xx</b>	3/8"	4.8	3.2	11.4	13.6	19.2	23.5	30.3	35.9	42.9	48	14	19
	<b>ECZ 2317 xx</b>		5.6	4.0	15.3	18.3	25.9	31.7	40.9	48.4	57.9			
	<b>ECZ 2410 xx</b>		6.4		20.0	24.0	33.9	41.5	53.6	63.4	75.8			
	<b>ECZ 2640 xx</b>		7.9		31.2	37.3	52.7	64.6	83.4	98.7	118			
	<b>EDZ 2940 xx</b>	1/2"	9.5	3.3	45.6	54.5	77.1	94.4	122	144	172	64	18	22
	<b>EDZ 3128 xx</b>		11.1	4.8	61.8	73.9	105	128	165	196	234			
	<b>EEZ 3165 xx</b>	3/4"	12.7	4.7	79.7	95.3	135	165	213	252	301	70	19	27
	<b>EFZ 3260 xx</b>	1"	15.9	6.3	126	150	212	260	336	397	475	92	25	36
	<b>EFZ 3372 xx</b>		19.0		180	215	304	372	480	568	679			
	<b>EHZ 3507 xx</b>	1 1/2"	22.2	7.9	245	293	414	507	655	774	926	111	27	50
	<b>EHZ 3663 xx</b>		25.4		320	383	541	663	856	1013	1210			
	<b>EHZ 3747 xx</b>		28.6		361	431	610	747	964	1141	1364			
	<b>EKZ 4109 xx</b>	2"	34.9	11.1	527	629	890	1090	1407	1665	1990	149	31	63
<b>EKZ 4139 xx</b>		38.1		671	803	1136	1391	1796	2125	2540				



THREAD SIZE CODE (RG)

EB	EC	ED	EE	EF	EH	EK	EM	EP
1/4"	3/8"	1/2"	3/4"	1"	1 1/2"	2"	3"	4"

HOW TO MAKE UP THE NOZZLE CODE

EX.: EBW 1550 B31

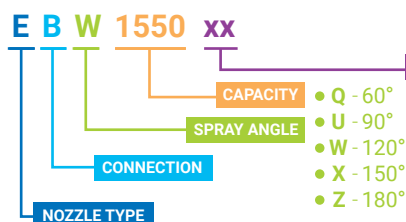

- B31 - AISI 316L Stainless steel
- T1 - Brass
- D1 - PVC
- D2 - PP
- D8 - PVDF
- E1 - PTFE
- L61 - Hastelloy C22
- Other materials on request



# E-X ( FULL CONE NOZZLES / WIDE PASSAGE )

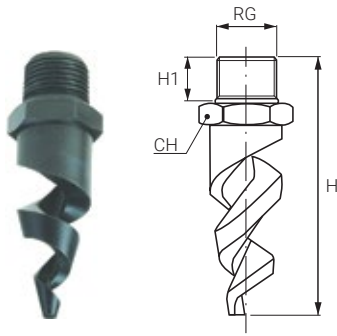

## SPIRAL NOZZLES / WIDE FREE PASSAGE

The E-X series nozzles, with their typical elongated spiral design, work on the impact principle, by deflection of a water stream onto their spiral profile that provides the desired spray angle. Their specific shape with no internal parts leaves a larger internal free passage suitable to work with higher capacities and for higher clog resistance than other nozzles of the same size.

The capacity values on darker background can be obtained with metal nozzles only as plastic nozzles cannot ensure resistance in harsh operating conditions. If the capacity values you are looking for are those on darker background, we recommend to chose metal nozzles for their longer operating life.

THREAD SPECIFICATION: BSPT, NPT



Spray section

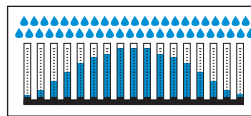

Convex distribution



- TYPICAL APPLICATIONS
- Gas cooling
  - Exhaust scrubbers
  - Desulfurization
  - Cooling
  - Other applications: Spray of chemicals
  - Fire prevention
  - Fire suppression

ANGLE	CODE	RG inch	D mm	D1 mm	Capacity at different pressure values (l/min) (bar)							Dimensions mm		
					0.7	1.0	2.0	3.0	5.0	7.0	10	H	H1	WS
120°	<b>ECW 2230 xx Xy</b>	3/8"	4.8	4.8	11.4	13.6	19.2	23.5	30.3	35.9	42.9	70	15	22
	<b>ECW 2317 xx Xy</b>		5.6	5.6	15.3	18.3	25.9	31.7	40.9	48.4	57.9			
	<b>ECW 2410 xx Xy</b>		6.4	6.4	20.0	24.0	33.9	41.5	53.6	63.4	75.8			
	<b>ECW 2640 xx Xy</b>		7.9	7.9	31.2	37.3	52.7	64.6	83.4	98.7	118			
	<b>EDW 2940 xx Xy</b>	1/2"	9.5	9.5	45.6	54.5	77.1	94.4	122	144	172	86	18	27
	<b>EDW 3128 xx Xy</b>		11.1	11.1	61.8	73.9	105	128	165	196	234			
	<b>EEW 3165 xx Xy</b>	3/4"	12.7	12.7	79.7	95.3	135	165	213	252	301	130	20	27
	<b>EFW 3260 xx Xy</b>	1"	16.0	16.0	126	150	212	260	336	397	475	131	26	34
	<b>EFW 3372 xx Xy</b>		19.0	19.0	180	215	304	372	480	568	679			
	<b>EHW 3507 xx Xy</b>	1 1/2"	22.2	22.2	245	293	414	507	655	774	926	171	27	50
	<b>EHW 3663 xx Xy</b>		25.4	25.4	320	383	541	663	856	1013	1210			
	<b>EHW 3747 xx Xy</b>		28.6	28.6	361	431	610	747	964	1141	1364			
	<b>EKW 4109 xx Xy</b>	2"	35.0	35.0	527	629	890	1090	1407	1665	1990	279	32	65
	<b>EKW 4139 xx Xy</b>		38.1	38.1	672	803	1136	1391	1796	2125	2540			
	<b>EMW 4204 xx Xy</b>	3"	44.5	44.5	985	1178	1666	2040	2634	3116	3725	267	32	90
	<b>EMW 4265 xx Xy</b>		51.0	51.0	1280	1530	2164	2650	3421	4048	4838			
<b>EPW 4412 xx Xy</b>	4"	63.5	63.5	1990	2379	3364	4120	5319	6293	7522	293	36	115	

## ES / SILICON CARBIDE NOZZLES

PNR designs and supplies spiral nozzles made out of several types of silicon carbide for applications where fluids containing abrasive solid particles must be sprayed and long nozzle service life is required.



ES / SILICON CARBIDE NOZZLES

## HOW TO MAKE UP THE NOZZLE CODE

Spiral nozzles with extra wide internal passage are widely used in pollution treatment and can be supplied with customized connections. Please refer to the picture of Silicon carbide nozzles on the left. Locknut fitting makes assembly easier and more convenient. This design, the only one possible for Silicon carbide nozzles, is optional for nozzles cast in alloys or stainless steel. To identify such nozzles, please note the following product coding.

### EHW 3747 xx Xy

- xx = Material code, see MATERIAL table
- y = CONNECTION CODE
  - B - BSPT, Male thread
  - N - NPT, Male thread
  - F - Locknut fitting

## HOW TO MAKE UP THE NOZZLE CODE

Ex.: ECW 2230 B31 XB

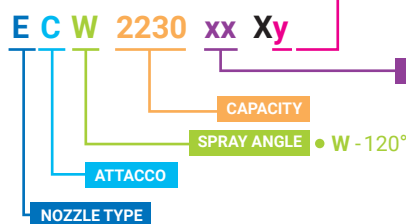

- B31 - AISI 316L Stainless steel
- T1 - Brass
- D1 - PVC
- D2 - PP
- D8 - PVDF
- E1 - PTFE
- L8 - Hastelloy C 276
- Other materials on request



# FLAT FAN NOZZLES



## CORRECT OVERLAPPING

When several nozzles are used to spray, it's very important to produce a uniform spray distribution. The correct sprays overlapping methods are shown here below.

### STANDARD CONVEX DISTRIBUTION

In a standard convex spray distribution the medium section has a larger capacity than the two lateral sections. It's necessary to overlap 50% of the spray range.

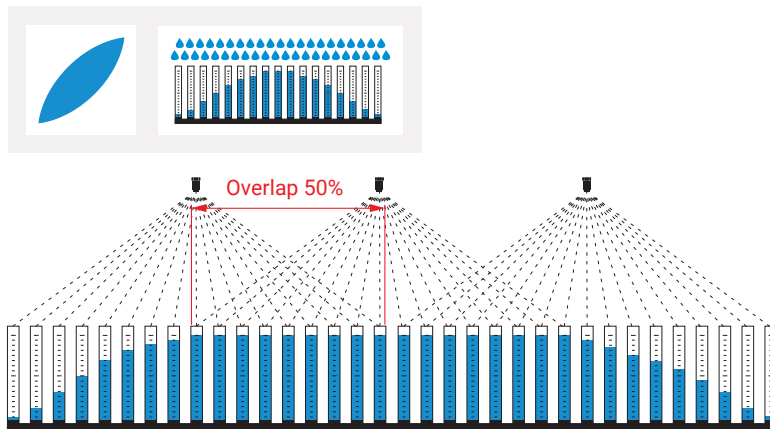

### STANDARD EVEN DISTRIBUTION

An equal distribution provides a uniform spray and 10% of the spray range overlaps.

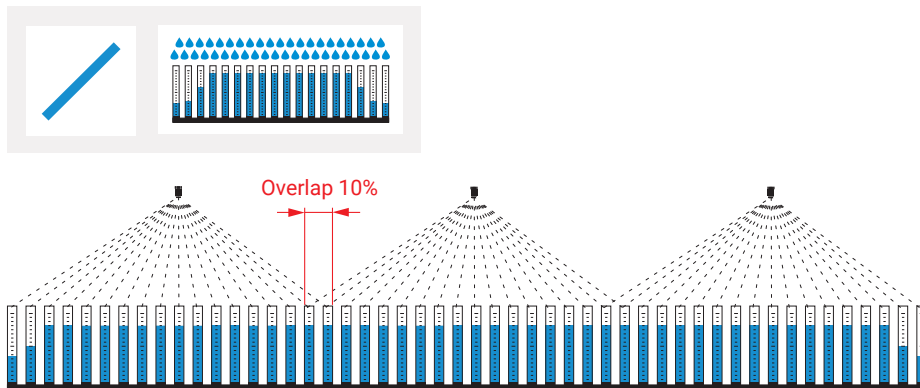

### OFFSET

A flat fan nozzle produces a high impact jet with a 5°-15° offset angle to avoid overlapping and interference. The offset angle depends on the spray range of the flat fan nozzle.

SPRAY ANGLE	OFFSET ( $\alpha$ )
15°~60°	5°~10°
60°~120°	10°~15°

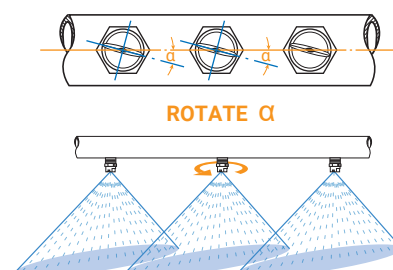

### FLAT FAN NOZZLES LOW PRESSURE, WIDE ANGLE

K series nozzles work on the principle of jet deflection, conveying the liquid against an accurately machined sloping surface to change the flow direction and produce a fan-shaped mist with a 75° spray angle. Medium-sized droplets and medium/low impact values.

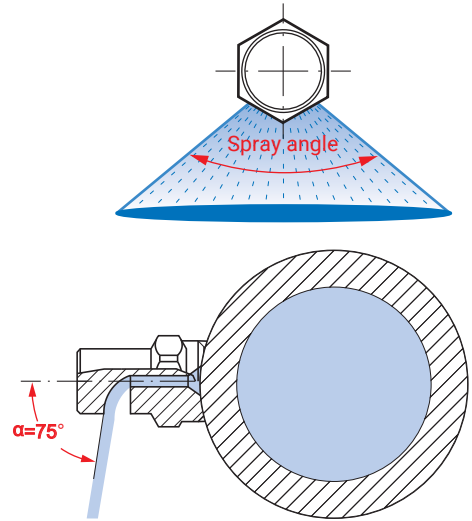

### FLAT FAN NOZZLES HIGH IMPACT

K nozzles high-impact type work on the principle of jet deflection. The liquid flow is conveyed onto a deflection sloping surface specially designed to produce a high impact narrow flat fan and medium-sized droplets. They are widely used in operating environments requiring high impact spray jets. Moreover, their rounded orifice and free inside passage minimize the risk of clogging. There is a specific angle that must be kept to ensure spray direction (see below picture ~ CL).

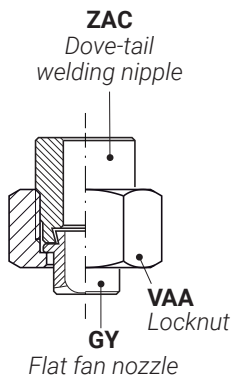
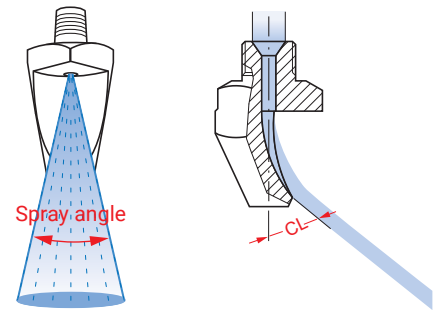

### DOVE-TAIL FLAT FAN NOZZLE

Flat fan nozzle tips provide a high impact spray. Adjacent nozzles must rotate with a specific offset angle to avoid interference and produce a uniform spray coverage when their jets overlap. For the GY series nozzle tips an offset angle  $\sim \alpha$  must be set between the spray plane and their dovetail guide.

Their specific dove-tail design ensures the correct spray direction and allows time saving as spray angles must not be adjusted each time. For thread size 3/8" offset angle is 5°. For thread size 3/4" offset angle is 15°. The picture to the right shows an offset angle  $\sim \alpha$  between the spray plane and the dovetail.

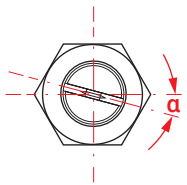
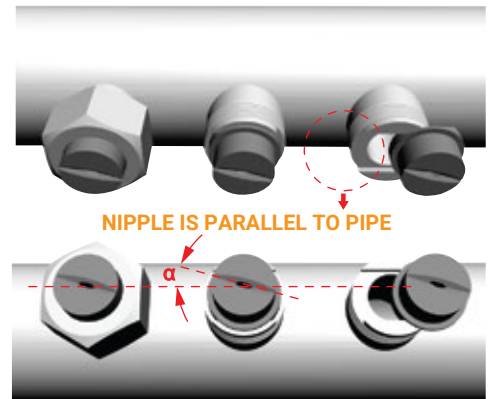

### EQUIVALENT NOZZLE TIP DIAMETER

Flat fan nozzles produce cat-eye shaped or parabolic distribution patterns with different capacities. Hence nozzle tips have long and short side differences. For convenience reasons, their "cat-eye shaped" spray pattern is converted into the area of a circle. The datum so obtained from the conversion is called "equivalent nozzle tip diameter".

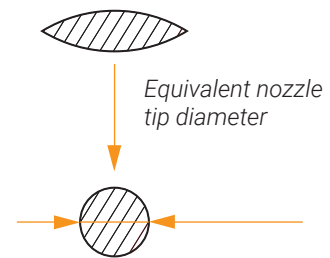

**CAT-EYE**  
STANDARD CONVEX DISTRIBUTION

**RECTANGLE**  
EVEN DISTRIBUTION

### FLANGED NOZZLE

Flanged nozzles have no thread. The nozzle tip is installed on a welding nipple and fastened with a locknut.

The scope of their design is:

1. Easy adjustment of the spray direction
2. Easy maintenance

The diagram below shows the possible mounting combinations:



### CLAMP / NIPPLE + FILTER + NOZZLE + LOCKNUT

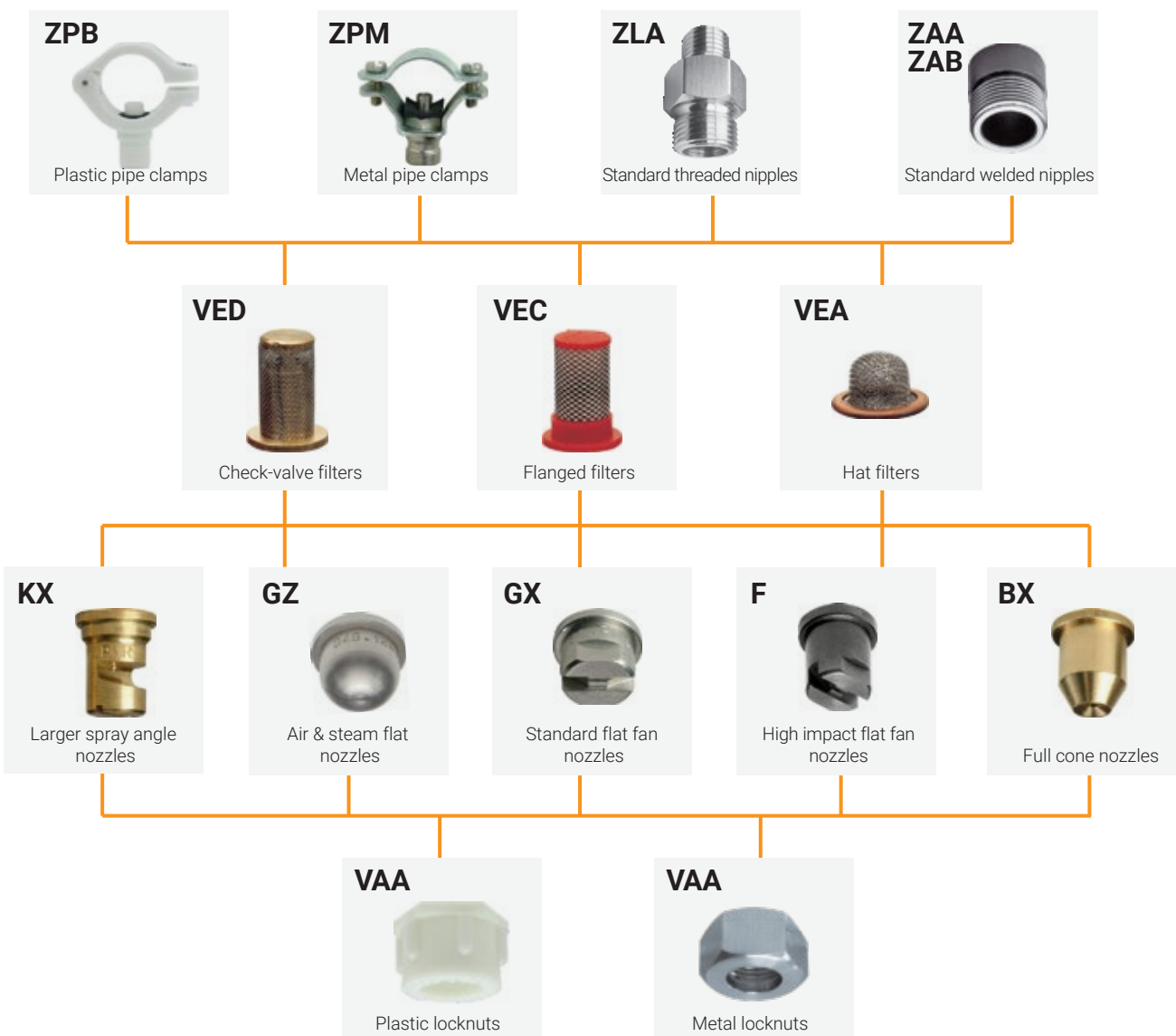
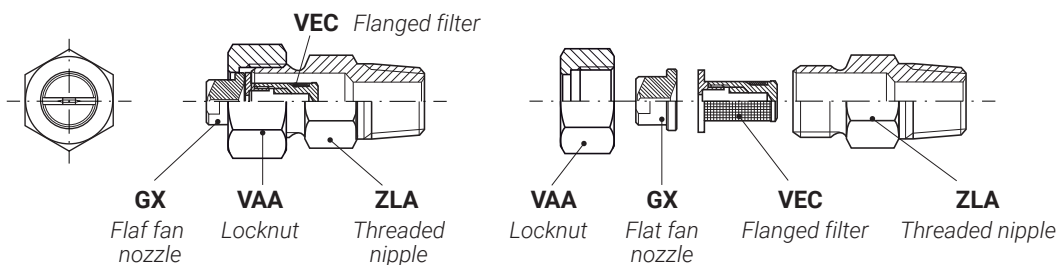

# F ( FLAT FAN NOZZLES / HIGH PRESSURE WASHING )



## HIGH PRESSURE WASHING

Flat fan nozzles F series are designed for high-pressure washing applications. Their specially designed inner profile allows for even jet distribution, which results in effective and uniform cleaning action over the surface being processed. All nozzles are precisely machined and made of hardened stainless steel AISI 416.

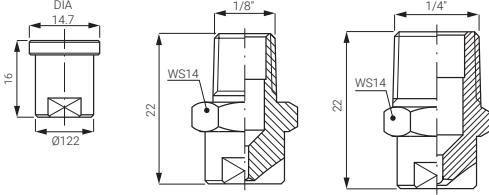

**FX** Flanged nozzle  
**FA** High pressure nozzle (1/8")  
**FB** High pressure nozzle (1/4")

THREAD SPECIFICATION: BSPT, NPT  
 TYPICAL APPLICATIONS  
 Car washing  
 High pressure washers  
 Industrial cleaning

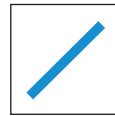

Spray section

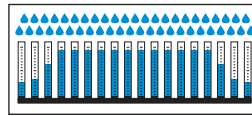

Even distribution



Nozzle type	Thread size
FA - FG	1/8" BSPT - NPT
FB - FH	1/4" BSPT - NPT
FX	Ø14.7

0°		15°			25°			40°			65°			US GALS	PNR CODE	Capacity at different pressure values (l/min) (bar)							
FAA	FBA	FXA	FAB	FBB	FXB	FAD	FBD	FXD	FAL	FBL	FXL	FAR	FBR			FXR	20	30	50	70	100	150	200
•	•	•	•	•	•	•	•	•	•	•	•	•	•	•	015	1340	1.52	1.86	2.40	2.84	3.40	4.16	4.81
•	•	•	•	•	•	•	•	•	•	•	•	•	•	•	02	1460	2.06	2.52	3.25	3.85	4.60	5.63	6.51
•	•	•	•	•	•	•	•	•	•	•	•	•	•	•	025	1560	2.50	3.07	3.96	4.69	5.60	6.86	7.92
•	•	•	•	•	•	•	•	•	•	•	•	•	•	•	03	1686	3.07	3.76	4.85	5.74	6.86	8.40	9.70
•	•	•	•	•	•	•	•	•	•	•	•	•	•	•	035	1812	3.63	4.45	5.74	6.79	8.12	9.94	11.5
•	•	•	•	•	•	•	•	•	•	•	•	•	•	•	04	1930	4.16	5.09	6.58	7.78	9.30	11.4	13.2
•	•	•	•	•	•	•	•	•	•	•	•	•	•	•	045	2103	4.61	5.64	7.28	8.62	10.3	12.6	14.6
•	•	•	•	•	•	•	•	•	•	•	•	•	•	•	05	2116	5.19	6.35	8.20	9.71	11.6	14.2	16.4
•	•	•	•	•	•	•	•	•	•	•	•	•	•	•	055	2126	5.63	6.90	8.91	10.5	12.6	15.4	17.8
•	•	•	•	•	•	•	•	•	•	•	•	•	•	•	06	2138	6.17	7.56	9.76	11.5	13.8	16.9	19.5
•	•	•	•	•	•	•	•	•	•	•	•	•	•	•	065	2149	6.66	8.16	10.5	12.5	14.9	18.2	21.1
•	•	•	•	•	•	•	•	•	•	•	•	•	•	•	07	2160	7.16	8.76	11.3	13.4	16.0	19.6	22.6
•	•	•	•	•	•	•	•	•	•	•	•	•	•	•	075	2170	7.60	9.31	12.0	14.2	17.0	20.8	24.0
•	•	•	•	•	•	•	•	•	•	•	•	•	•	•	08	2181	8.09	9.91	12.8	15.1	18.1	22.2	25.6
•	•	•	•	•	•	•	•	•	•	•	•	•	•	•	085	2192	8.59	10.5	13.6	16.1	19.2	23.5	27.2
•	•	•	•	•	•	•	•	•	•	•	•	•	•	•	09	2204	9.12	11.2	14.4	17.1	20.4	25.0	28.8
•	•	•	•	•	•	•	•	•	•	•	•	•	•	•	095	2226	10.1	12.4	16.0	18.9	22.6	27.7	32.0
•	•	•	•	•	•	•	•	•	•	•	•	•	•	•	10	2230	10.3	12.6	16.3	19.2	23.0	28.2	32.5
•	•	•	•	•	•	•	•	•	•	•	•	•	•	•	11	2248	11.1	13.6	17.5	20.7	24.8	30.4	35.1
•	•	•	•	•	•	•	•	•	•	•	•	•	•	•	12	2272	12.2	14.9	19.2	22.8	27.2	33.3	38.5
•	•	•	•	•	•	•	•	•	•	•	•	•	•	•	12.5	2280	12.5	15.3	19.8	23.4	28.0	34.3	39.6
•	•	•	•	•	•	•	•	•	•	•	•	•	•	•	13	2296	13.2	16.2	20.9	24.8	29.6	36.3	41.9
•	•	•	•	•	•	•	•	•	•	•	•	•	•	•	14	2320	14.3	17.5	22.6	26.8	32.0	39.2	45.3
•	•	•	•	•	•	•	•	•	•	•	•	•	•	•	15	2341	15.2	18.7	24.1	28.5	34.1	41.8	48.2
•	•	•	•	•	•	•	•	•	•	•	•	•	•	•	16	2360	16.1	19.7	25.5	30.1	36.0	44.1	50.9
•	•	•	•	•	•	•	•	•	•	•	•	•	•	•	18	2410	18.3	22.5	29.0	34.3	41.0	50.2	58.0
•	•	•	•	•	•	•	•	•	•	•	•	•	•	•	20	2456	20.4	25.0	32.2	38.2	45.6	55.8	64.5
•	•	•	•	•	•	•	•	•	•	•	•	•	•	•	25	2567	25.4	31.1	40.1	47.4	56.7	69.4	80.2
•	•	•	•	•	•	•	•	•	•	•	•	•	•	•	30	2682	30.5	37.4	48.2	57.1	68.2	83.5	96.4
•	•	•	•	•	•	•	•	•	•	•	•	•	•	•	35	2800	35.8	43.8	56.6	66.9	80.0	98.0	113
•	•	•	•	•	•	•	•	•	•	•	•	•	•	•	40	2910	40.7	49.8	64.3	76.1	91.0	111	128
•	•	•	•	•	•	•	•	•	•	•	•	•	•	•	50	3113	50.5	61.9	79.9	94.5	113	138	160
•	•	•	•	•	•	•	•	•	•	•	•	•	•	•	60	3135	60.4	73.9	95.5	113	135	165	191

HOW TO MAKE UP THE NOZZLE CODE

Ex.: FAA 1340 C2

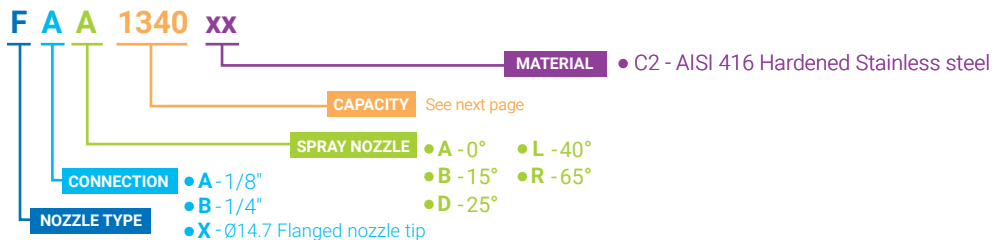



# ( FLAT FAN NOZZLES / HIGH PRESSURE WASHING ) F

OUTER DIMENSION OF F TYPE NOZZLES AND FX NOZZLE TIPS (CODE)

The table on the right shows the correspondence between the nominal capacity in US Gallons per minute at 40 psi, which is commonly used to identify high pressure washing nozzles and the PNR capacity code at 100 bar. For the convenience of worldwide use, all nozzles are US coding system.

For example:

**FBA 1686 C2** (PNR code) nozzle will be codified as **00/03** (US Gallons) with a spray angle 0° and capacity 0.3 Gals/min at a pressure of 40 psi.

**FBD 2116 C2** (PNR code) nozzle will be codified as **25/05** (US Gallons) with a spray angle 25° and capacity 0.5 Gals/min at a pressure of 40 psi. (see below)

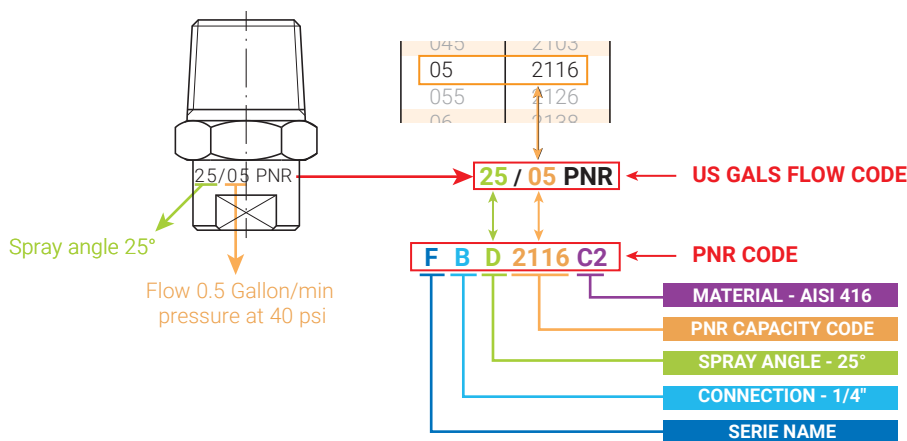

US GALLONS	PNR CODE
015	1340
02	1460
025	1560
03	1686
035	1812
04	1930
045	2103
05	2116
055	2126
06	2138
065	2149
07	2160
075	2170
08	2181
085	2192
09	2204
095	2220
10	2230
11	2248
12	2272
12.5	2280
13	2296
14	2320
15	2341
16	2360
18	2410
20	2456
25	2567
30	2682
35	2800
40	2910
50	3113
60	3135

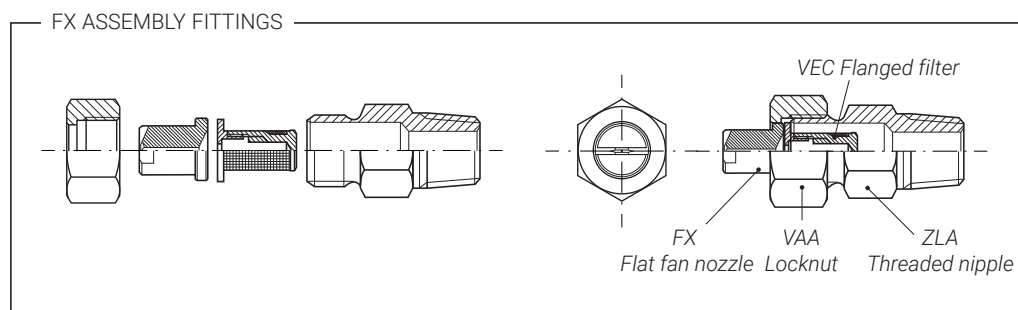

## HIGH PRESSURE WASHING ACCESSORIES

We have all kinds of washing guns (low/medium/high/superhigh pressure) and accessories for various washing applications and environments. We will help you to chose the best solution for your needs.



**UMW 0010 D4**  
High pressure gun  
P. 97



**UMW 0020 D4**  
High pressure gun  
P. 97



**UMW 0030 B3**  
High pressure lance  
P. 98



**UMW 0045 B3**  
High pressure lance  
P. 98



**UMU J/I**  
Auto-rewind reelst  
P. 102

## OPTIONAL ELEMENT- FLOW STRAIGHTENER

Flow straighteners improve spray jet efficiency by straightening the liquid path to minimize turbulence and produce swirl-free, even, stable and straight-run flows. All PNR nozzles are ready to embed a flow straightener. These items can be supplied separately on request.



# GA (FLAT FAN NOZZLES / SHORT BODY)

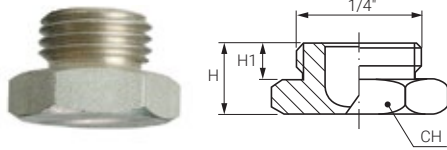

1/4" Standard Capacity

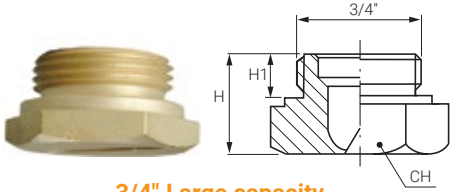

3/4" Large capacity

## SHORT BODY

The special short body design of the GA nozzles makes it possible to use nozzle spray pipes in such machines or systems where the available space is very limited. (for ex., tight turns in traps and elbows).

They allow an even jet distribution and a proper force of impact. GA nozzles are available in two types: 1/4" standard capacity and 3/4" large capacity. They are made in brass, stainless steel or in plastic materials to suit different working environments. GA nozzles in plastic materials are made with a longer thread and bigger front for higher efficiency and longer service life.

THREAD SPECIFICATION: BSP



Spray section

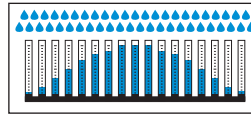

Convex distribution



### TYPICAL APPLICATIONS

*Washing:*

Filter cleaning in paper making machines and dryers

*Cooling:*

Continuous casting  
Product cooling

*Other applications:*

Spray of chemicals  
Water curtains for toxic gases suppression  
Excellent for pipe, sewer and drain cleaning

CAPACITY CODE	Capacity at different pressure values									(l/min) (bar)
	0.5	1.0	1.5	2.0	3.0	4.0	5.0	7.0	10	
BSP 1/4" THREADED	0780*	0,32	0,45	0,55	0,64	0,78	0,9	1,01	1,19	1,42
	1124	0,51	0,72	0,88	1,01	1,24	1,43	1,6	1,89	2,27
	1160	0,65	0,92	1,13	1,31	1,6	1,85	2,07	2,44	2,92
	1190	0,78	1,1	1,34	1,55	1,9	2,19	2,45	2,9	3,47
	1233	0,95	1,35	1,65	1,9	2,33	2,69	3,01	3,56	4,25
	1244	1	1,41	1,73	1,99	2,44	2,82	3,15	3,73	4,45
	1310	1,27	1,79	2,19	2,53	3,1	3,58	4	4,74	5,66
	1385	1,57	2,22	2,72	3,14	3,85	4,45	4,97	5,88	7,03
	1490	2	2,83	3,46	4	4,9	5,66	6,33	7,48	8,95
	1581	2,37	3,35	4,11	4,74	5,81	6,71	7,5	8,87	10,61
	1780	3,18	4,5	5,52	6,37	7,8	9,01	10,07	11,91	14,24
	1980	4	5,66	6,93	8	9,8	11,32	12,65	14,97	17,89
	2124	5,1	7,2	8,8	10,1	12,4	14,3	16	18,9	22,6
2153	6,2	8,8	10,8	12,5	15,3	17,7	19,8	23,4	27,9	
2194	7,9	11,2	13,7	15,8	19,4	22,4	25	29,6	35,4	
2245	10	14,1	17,3	20	24,5	28,3	31,6	37,4	44,7	

\* Not available in B31, D2 and E1.

CAPACITY CODE	Capacity at different pressure values									(l/min) (bar)
	0.5	1.0	1.5	2.0	3.0	4.0	5.0	7.0	10	
BSP 3/4" THREADED	2154	6,2	8,8	10,8	12,5	15,3	17,7	19,8	23,4	27,9
	2195	7,9	11,2	13,7	15,8	19,4	22,4	25	29,6	35,4
	2246	10	14,1	17,3	20	24,5	28,3	31,6	37,4	44,7
	2311	12,7	18	22	25,4	31,1	35,9	40,1	47,5	56,8
	2490	20	28,3	34,6	40	49	56,6	63,3	74,8	89,5
	2610	24,9	35,2	43,1	49,8	61	70,4	78,8	93,2	111,4
	2760	31	43,9	53,7	62,1	76	87,8	98,1	116,1	138,8
	2930	38	53,7	65,8	75,9	93	107,4	120,1	142,1	169,8
	3122	49,8	70,4	86,3	99,6	122	140,9	157,5	186,4	222,7

Longer thread and bigger front design for short-body nozzles in plastic to ensure safer operating performances and longer service life.



Material	Dimensions (mm)					
	Small size (1/4")			Large size (3/4")		
	H	H1	CH	H	H1	CH
B1 - AISI 303 SS	12	7	17	15	8	32
B31 - AISI 316L SS						
T1 - Brass	17	7	17	23	11	32
D2 - PP						
E1 - PTFE						
D1 - PVC						

HOW TO MAKE UP THE NOZZLE CODE  
EX.: GAM 1490 B1

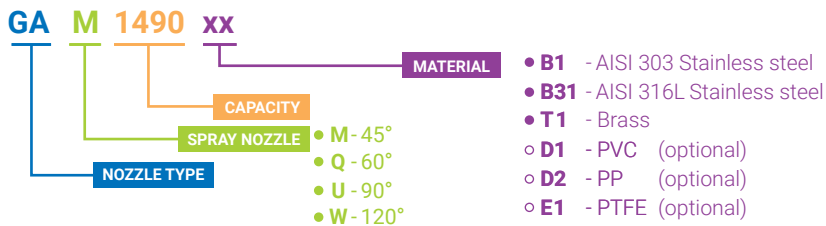

( FLAT FAN NOZZLE TIPS ) **GX**

LOW CAPACITY

Flat fan nozzle tips are usually mounted onto a pipe by means of a welded nipple or a clamp, and secured in place with a retaining nut. They can be easily replaced and the jet can be conveniently oriented in the desired direction.

The tips models shown on this page delivery very low flow values. Their precisely machined small orifices can be protected from clogging by means of a filter assembled inside our nipples and clamps that are designed for this purpose.

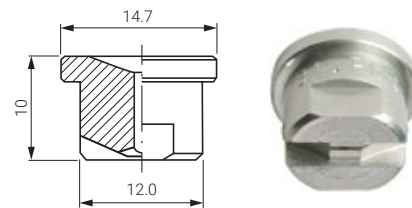

CONNECTION: flange

TYPICAL APPLICATIONS

Washing: semiconductor and precision parts cleaning

Cooling: continuous casting, product cooling

Lubrication: spray of lubricating oils and release agents

Other applications: spray of flavouring agents, cooling oil and antifoulant chemicals

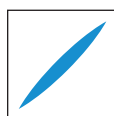

Spray section

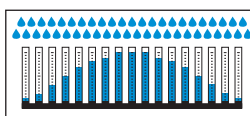

Convex distribution

GXD 25°	GXL 40°	GXN 50°	GXR 65°	CAPACITY CODE	D mm	Capacity at different pressure values (l/min) (bar)									
						0.7	1.0	1.5	2.0	3.0	4.0	5.0	7.0	10	
			•	0060	0.28	0.02	0.03	0.04	0.05	0.06	0.07	0.08	0.09	0.11	
			•	0100	0.34	0.05	0.06	0.07	0.08	0.10	0.12	0.13	0.15	0.18	
			•	0130	0.38	0.06	0.08	0.09	0.11	0.13	0.15	0.17	0.20	0.24	
•	•	•	•	0150	0.40	0.07	0.09	0.11	0.12	0.15	0.17	0.19	0.23	0.27	
•	•	•	•	0200	0.46	0.08	0.12	0.14	0.16	0.20	0.23	0.26	0.31	0.37	
•	•	•	•	0260	0.53	0.11	0.15	0.18	0.21	0.26	0.30	0.34	0.40	0.47	
•	•	•	•	0390	0.66	0.16	0.23	0.28	0.32	0.39	0.45	0.50	0.60	0.71	
•	•	•	•	0590	0.79	0.24	0.34	0.42	0.48	0.59	0.68	0.76	0.90	1.08	

GXS 75°	GXT 80°	GXV 95°	GXJ 110°	CAPACITY CODE	D mm	Capacity at different pressure values (l/min) (bar)									
						0.7	1.0	1.5	2.0	3.0	4.0	5.0	7.0	10	
•				0100	0.34	0.05	0.06	0.07	0.08	0.10	0.12	0.13	0.15	0.18	
•				0130	0.38	0.06	0.08	0.09	0.11	0.13	0.15	0.17	0.20	0.24	
•	•	•	•	0150	0.40	0.07	0.09	0.11	0.12	0.15	0.17	0.19	0.23	0.27	
•	•	•	•	0200	0.46	0.08	0.12	0.14	0.16	0.20	0.23	0.26	0.31	0.37	
•	•	•	•	0260	0.53	0.11	0.15	0.18	0.21	0.26	0.30	0.34	0.40	0.47	
•	•	•	•	0390	0.66	0.16	0.23	0.28	0.32	0.39	0.45	0.50	0.60	0.71	
•	•	•	•	0590	0.79	0.24	0.34	0.42	0.48	0.59	0.68	0.76	0.90	1.08	

ASSEMBLY FITTINGS

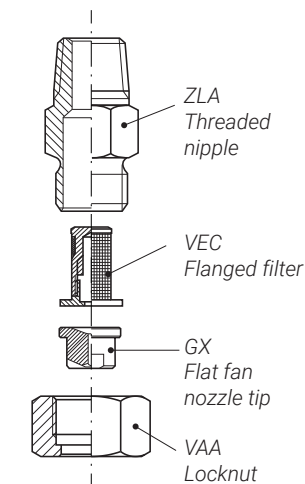

MATERIAL PROCESSING

Because of the extreme difficulty of working hard materials such as stainless steels with very small profile drills, not all the capacity sizes shown in the nozzle table are available in all materials. The table below shows the minimum capacity values we can produce for each given material. Please contact our sales for more information.

Material	0060	0100	0130	0150	0200	0260	0390	0590	0780
<b>B31</b> - AISI 316L					•	•	•	•	•(1)
<b>B1</b> - AISI 303	•	•	•	•	•	•	•	•	•(2)
<b>T1</b> - Brass	•	•	•	•	•	•	•	•	•(2)

- (1) Low capacity body
- (2) Standard capacity body

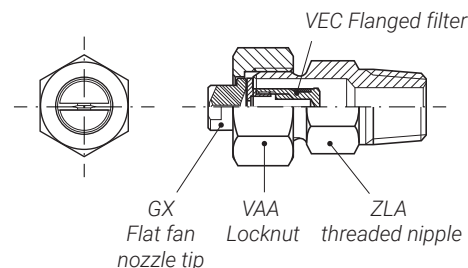

HOW TO MAKE UP THE NOZZLE CODE

Ex.: GXD 0390 B1

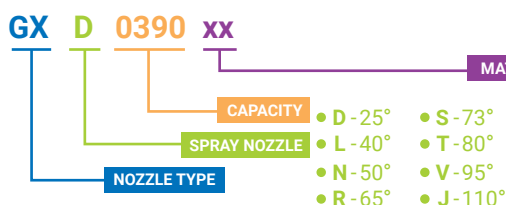

- **B1** - AISI 303 Stainless steel
- **B31** - AISI 316L Stainless steel
- **T1** - Brass

# GX (FLAT FAN NOZZLE TIPS)



3/8" Standard capacity

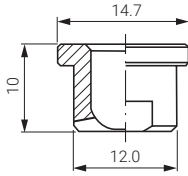

3/4" Large capacity

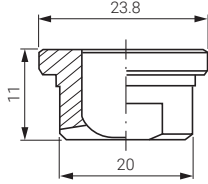

## STANDARD AND LARGE CAPACITIES

Flat fan nozzle tips are usually mounted onto a pipe by means of a welded 3/8" nipple or a clamp, and secured in place with a retaining nut. They can be easily replaced and their jet can be conveniently oriented in the desired direction. These nozzle are available in two types: 3/8" standard capacity and 3/4" large capacity. The tip is assembled with a pipe clamp, a welding nipple and a locknut.

CONNECTION: Flange

TYPICAL APPLICATIONS

- Washing:* filter cloth cleaning, parts cleaning, vehicles cleaning
- Cooling:* steel cooling, product cooling
- Lubrication:* spray of lubricating oil and release agents
- Other applications:* spray of antifoulant chemicals, etc.



Spray section

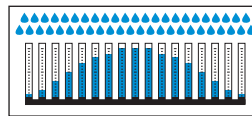

Convex distribution



## 3/8" PLASTIC TIPS



**NEW** Also available in high quality PVDF

GXQ 60°	GXU 90°	GXJ 110°	CODE	D mm	(l/min) (bar)								
					0.5	1.0	1.5	2.0	3.0	4.0	5.0	7.0	10
		•	<b>0780</b>	0.91	0.32	0.45	0.55	0.64	0.78	0.90	1.01	1.19	1.42
•		•	<b>1120</b>	1.10	0.49	0.69	0.85	0.98	1.20	1.39	1.55	1.83	2.19
•	•	•	<b>1233</b>	1.50	0.95	1.35	1.65	1.90	2.33	2.69	3.01	3.56	4.25
	•	•	<b>1310</b>	1.70	1.27	1.79	2.19	2.53	3.10	3.58	4.00	4.74	5.66
	•	•	<b>1490</b>	2.10	2.00	2.83	3.46	4.00	4.90	5.66	6.33	7.48	8.95

## ASSEMBLY FITTINGS

In the table you can check the available 3/8" GX tips, manufactured in plastic material (D82 - molded PVDF).

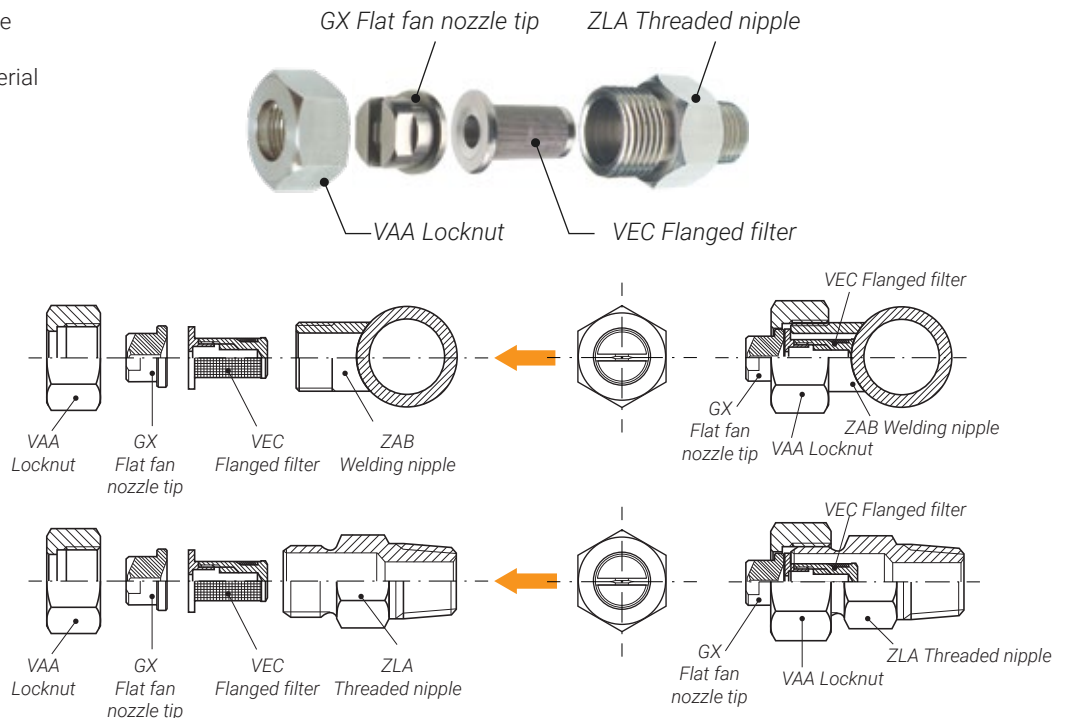

### HOW TO MAKE UP THE NOZZLE CODE

Ex.: GXA 1310 B1

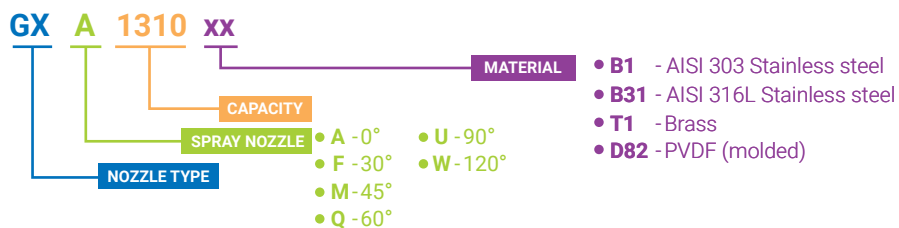

( FLAT FAN NOZZLES TIPS ) **GX**

3/8" STANDARD CAPACITY TIPS

GXA 0°	GXF 30°	GXM 45°	GXQ 60°	GXU 90°	GXW 120°	CODE	D mm	Capacity at different pressure values								(l/min) (bar)	
								0.5	1.0	1.5	2.0	3.0	4.0	5.0	7.0	10	
								•	•	•	•	•	•	<b>0780</b>	0.91	0.32	0.45
•	•	•	•	•	•	<b>1120</b>	1.10	0.49	0.69	0.85	0.98	1.20	1.39	1.55	1.83	2.19	
•	•	•	•	•	•	<b>1160</b>	1.30	0.65	0.92	1.13	1.31	1.60	1.85	2.07	2.44	2.92	
•	•	•	•	•	•	<b>1190</b>	1.30	0.78	1.10	1.34	1.55	1.90	2.19	2.45	2.90	3.47	
•	•	•	•	•	•	<b>1233</b>	1.50	0.95	1.35	1.65	1.90	2.33	2.69	3.01	3.56	4.25	
•	•	•	•	•	•	<b>1310</b>	1.70	1.27	1.79	2.19	2.53	3.10	3.58	4.00	4.74	5.66	
•	•	•	•	•	•	<b>1385</b>	1.80	1.57	2.22	2.72	3.14	3.85	4.45	4.97	5.88	7.03	
•	•	•	•	•	•	<b>1490</b>	2.10	2.00	2.83	3.46	4.00	4.90	5.66	6.33	7.48	8.95	
•	•	•	•	•	•	<b>1581</b>	2.30	2.37	3.35	4.11	4.74	5.81	6.71	7.50	8.87	10.6	
•	•	•	•	•	•	<b>1780</b>	2.70	3.18	4.50	5.52	6.37	7.80	9.01	10.1	11.9	14.2	
•	•	•	•	•	•	<b>1980</b>	3.00	4.00	5.66	6.93	8.00	9.80	11.3	12.7	15.0	17.9	
•	•	•	•	•	•	<b>2124</b>	3.40	5.06	7.16	8.77	10.1	12.4	14.3	16.0	18.9	22.6	
•	•	•	•	•	•	<b>2153</b>	3.80	6.25	8.83	10.8	12.5	15.3	17.7	19.8	23.4	27.9	
•	•	•	•	•	•	<b>2194</b>	4.30	7.92	11.2	13.7	15.8	19.4	22.4	25.0	29.6	35.4	
•	•	•	•	•	•	<b>2245</b>	4.80	10.0	14.1	17.3	20.0	24.5	28.3	31.6	37.4	44.7	

**IMPORTANT**  
Nozzle **GXx 0780 B31** is made with "low capacity" body, while when it's fabricated with other materials is made with "standard capacity" body.

3/4" LARGE CAPACITY TIPS

GXA 0°	GXF 30°	GXM 45°	GXQ 60°	GXU 90°	GXW 120°	CODE	D mm	Capacity at different pressure values								(l/min) (bar)	
								0.5	1.0	1.5	2.0	3.0	4.0	5.0	7.0	10	
								•	•	•	•	•	•	<b>1781</b>	2.70	3.18	4.50
•	•	•	•	•	•	<b>1981</b>	3.00	4.00	5.66	6.93	8.00	9.80	11.3	12.7	15.0	17.9	
•	•	•	•	•	•	<b>2125</b>	3.40	5.06	7.16	8.77	10.1	12.4	14.3	16.0	18.9	22.6	
•	•	•	•	•	•	<b>2154</b>	3.80	6.25	8.83	10.8	12.5	15.3	17.7	19.8	23.4	27.9	
•	•	•	•	•	•	<b>2195</b>	4.30	7.92	11.2	13.7	15.8	19.4	22.4	25.0	29.6	35.4	
•	•	•	•	•	•	<b>2246</b>	4.80	10.0	14.1	17.3	20.0	24.5	28.3	31.6	37.4	44.7	
•	•	•	•	•	•	<b>2311</b>	5.40	12.7	18.0	22.0	25.4	31.1	35.9	40.1	47.5	56.8	
•	•	•	•	•	•	<b>2490</b>	6.40	20.0	28.3	34.6	40.0	49.0	56.6	63.3	74.8	89.5	
•	•	•	•	•	•	<b>2610</b>	7.50	24.9	35.2	43.1	49.8	61.0	70.4	78.8	93.2	111	
•	•	•	•	•	•	<b>2760</b>	8.30	31.0	43.9	53.7	62.1	76.0	87.8	98.1	116	139	
•	•	•	•	•	•	<b>3122</b>	12.5	49.8	70.4	86.3	99.6	122	141	158	186	223	

ASSEMBLY FITTINGS CODING

Name	Code and material	Appearance	Standard size 3/8"	Large size 3/4"
Locknut <b>P.90</b>	<b>B1</b> - AISI 303 <b>B31</b> - AISI 316L <b>T1</b> - Brass <b>D6</b> - Fiberglass reinforced PP		VAA 0380 <b>xxB</b>	VAA 0750 <b>xxB</b>
Welding nipple <b>P.91</b>	<b>B1</b> - AISI 303 <b>B31</b> - AISI 316L		ZAA C018 <b>xxG</b>	ZAA E027 <b>xxG</b>
Threaded nipple <b>P.91</b>	<b>B1</b> - AISI 303 <b>B31</b> - AISI 316L <b>T1</b> - Brass		ZLA 2538 <b>xxB</b>	ZLA 7575 <b>xxB</b>
Metal pipe clamp <b>P.89</b>	<b>B1</b> - AISI 303 <b>T1</b> - Brass		ZPM	—
Plastic pipe clamp <b>P.88</b>	<b>D6</b> - Fiberglass reinforced PP		ZPB 0050 D6	—
Plastic bayonet pipe clamp <b>P.88</b>	<b>D82</b> - PVDF		ZPC 0500 D82P	—
Flanged filter <b>P.94</b>	<b>B1</b> - AISI 303 <b>B31</b> - AISI 316L <b>T1</b> - Brass <b>D3</b> - Polyamide		VEC 0138 <b>xx</b>	—



# GY ( DOVE-TAIL FLAT FAN TIPS )

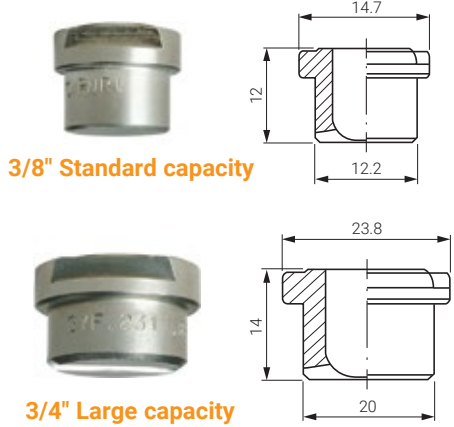

## STANDARD AND LARGE CAPACITIES

GY flat fan nozzle tips are usually mounted onto a pipe by means of a welding nipple and secured in place with a retaining nut. Therefore, they can be easily replaced and their dove-tail connection assures an always precise assembly as the nozzle can be assembled only when the flat fan is properly oriented. They are available in three types: 3/8" standard capacity, 3/4" large capacity and 1" extra-large capacity. The tip models shown on this page deliver the most popular capacity values, while GY flat fan tips with bigger capacities and sizes can be manufactured on request and supplied with matching dovetail nipples and retaining nuts. Please find information about instalment and accessories on page 91.

CONNECTION: Dovetail flat fan tips  
 TYPICAL APPLICATIONS  
 Washing: steel cleaning, filter cloth cleaning, parts cleaning  
 Cooling: steel cooling, product cooling

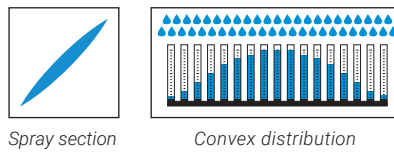

## SPRAY ANGLE CODES

GYA	GYF	GYM	GYQ	GYU	GYW
0°	30°	45°	60°	90°	120°

## ASSEMBLY FITTINGS

The picture below shows a GY nozzle tip (in the middle) assembled with a dove-tail nipple (right) and a locknut (left).

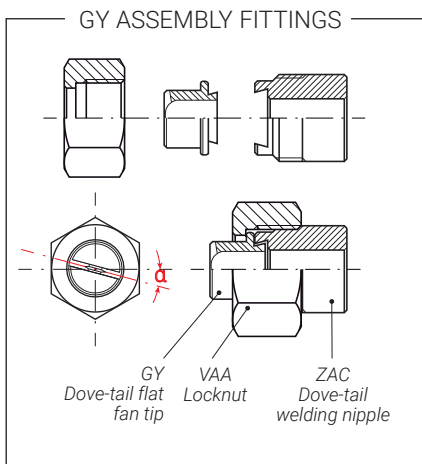
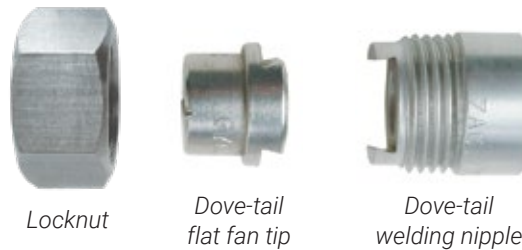

## NDOVE-TAIL NIPPLES

GY nozzle tips are assembled onto their own series of matching dovetail nipples, to assure perfect alignment: the two tip sizes require nipples and caps as shown in the table below.

The orientation of the spray jets, properly inclined to avoid their interfering, is automatically obtained welding the nipples in place with their dovetail aligned along the pipe axis. This is easily done by running a straight rule across the dovetail profile machined on the nipple.

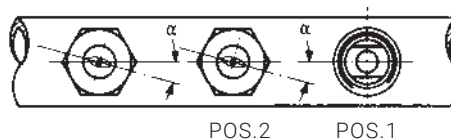

See values for jet deviation angle ( $\alpha$ ) beside capacity tables next page.

### HOW TO MAKE UP THE NOZZLE CODE

Ex.: GYF 1190 B1

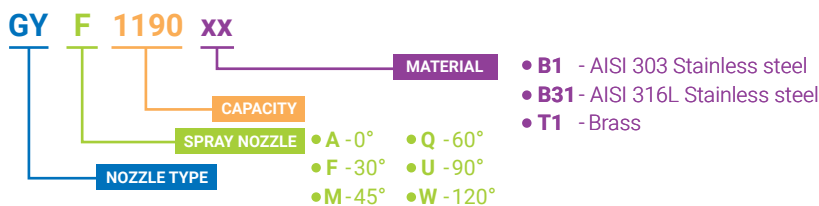

( DOVE-TAIL FLAT FAN TIPS ) **GY**

STANDARD AND LARGE CAPACITIES

3/8" STANDARD CAPACITY TIPS

Jet deviation angle  $\alpha = 5^\circ$

GYF 30°	GYM 45°	GYQ 60°	GYU 90°	GYW 120°	CAPACITY CODE	D mm	Capacity at different pressure values								(l/min) (bar)
							0.5	1.0	1.5	2.0	3.0	4.0	5.0	7.0	
•	•	•	•	•	<b>1190</b>	1.30	0.78	1.10	1.34	1.55	1.90	2.19	2.45	2.90	3.47
•	•	•	•	•	<b>1233</b>	1.50	0.95	1.35	1.65	1.90	2.33	2.69	3.01	3.56	4.25
•	•	•	•	•	<b>1310</b>	1.70	1.27	1.79	2.19	2.53	3.10	3.58	4.00	4.74	5.66
•	•	•	•	•	<b>1385</b>	1.80	1.57	2.22	2.72	3.14	3.85	4.45	4.97	5.88	7.03
•	•	•	•	•	<b>1490</b>	2.10	2.00	2.83	3.46	4.00	4.90	5.66	6.33	7.48	8.95
•	•	•	•	•	<b>1581</b>	2.30	2.37	3.35	4.11	4.74	5.81	6.71	7.50	8.87	10.6
•	•	•	•	•	<b>1780</b>	2.70	3.18	4.50	5.52	6.37	7.80	9.01	10.1	11.9	14.2
•	•	•	•	•	<b>1980</b>	3.00	4.00	5.66	6.93	8.00	9.80	11.3	12.7	15.0	17.9
•	•	•	•	•	<b>2124</b>	3.40	5.06	7.16	8.77	10.1	12.4	14.3	16.0	18.9	22.6
•	•	•	•	•	<b>2153</b>	3.80	6.25	8.83	10.8	12.5	15.3	17.7	19.8	23.4	27.9
•	•	•	•	•	<b>2194</b>	4.30	7.96	11.3	13.8	15.9	19.5	22.5	25.2	29.8	35.6

3/4" LARGE CAPACITY TIPS

Jet deviation angle  $\alpha = 15^\circ$

GYA 0°	GYF 30°	GYM 45°	GYQ 60°	GYU 90°	GYW 120°	CAPACITY CODE	D mm	Capacity at different pressure values								(l/min) (bar)
								0.5	1.0	1.5	2.0	3.0	4.0	5.0	7.0	
	•	•	•	•	•	<b>1781</b>	2.70	3.18	4.50	5.52	6.37	7.80	9.01	10.1	11.9	14.2
	•	•	•	•	•	<b>1981</b>	3.00	4.00	5.66	6.93	8.00	9.80	11.3	12.7	15.0	17.9
•	•	•	•	•	•	<b>2125</b>	3.40	5.06	7.16	8.77	10.1	12.4	14.3	16.0	18.9	22.6
•	•	•	•	•	•	<b>2154</b>	3.80	6.25	8.83	10.8	12.5	15.3	17.7	19.8	23.4	27.9
•	•	•	•	•	•	<b>2195</b>	4.30	7.92	11.2	13.7	15.8	19.4	22.4	25.0	29.6	35.4
•	•	•	•	•	•	<b>2246</b>	4.80	10.0	14.2	17.4	20.1	24.6	28.4	31.8	37.6	44.9
•	•	•	•	•	•	<b>2311</b>	5.40	12.7	18.0	22.0	25.4	31.1	35.9	40.1	47.5	56.8
•	•	•	•	•	•	<b>2490</b>	6.40	20.0	28.3	34.6	40.0	49.0	56.6	63.3	74.8	89.5
•	•	•	•	•	•	<b>2610</b>	7.50	24.9	35.2	43.1	49.8	61.0	70.4	78.8	93.2	111
	•	•	•	•	•	<b>2760</b>	8.30	31.0	43.9	53.7	62.1	76.0	87.8	98.1	116	139
	•	•	•	•	•	<b>3122</b>	12.5	49.8	70.4	86.3	99.6	122	141	158	186	223

ASSEMBLY FITTINGS CODING

Name	Material code	Appearance	Model no.	
			Standard size 3/8"	Large size 3/4"
Locknut <i>P.90</i>	<b>B1</b> - AISI 303 <b>B31</b> - AISI 316L <b>T1</b> - Ottone		VAA 0381 <b>xxB</b>	VAA 0750 <b>xxB</b>
Dove-tail welding nipple <i>P.91</i>	<b>B1</b> - AISI 303 <b>B31</b> - AISI 316L		ZAC C018 <b>xx</b>	ZAC E027 <b>xx</b>

HOW TO MAKE UP THE NOZZLE CODE

Ex.: GYF 1190 B1

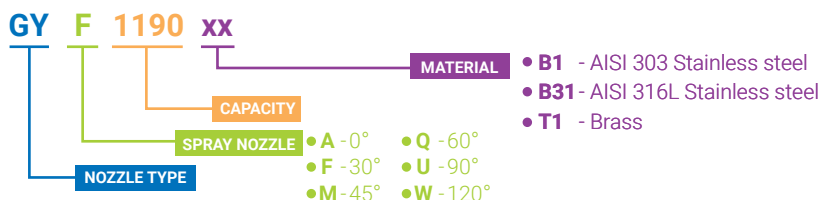

# HT ( QUICK-CONNECT FLAT FAN NOZZLES )

## STANDARD AND LARGE CAPACITY

The HT series flat fan nozzles offer the same quality and technical characteristics of the standard types but also the additional convenience of a bayonet coupling which allows a simple assembly with no need of tools and an automatic spray pattern alignment. The optimum performance of your system or machine is then conveniently safeguarded, with a noticeable reduction in service cost and production loss for system downtime. HT series are widely applied to working environments that are easy to clog. HT nozzles are available with low, *standard* and *large*.

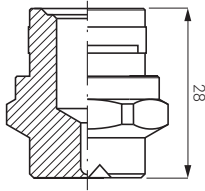
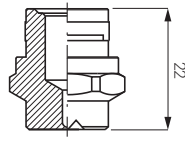

Spray section

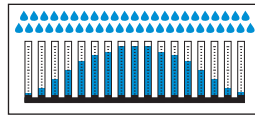

Convex distribution



### QUICK-CONNECT NOZZLES

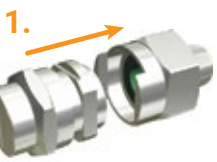

HT + ZHS

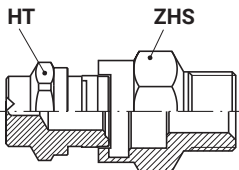

HT

ZHS

HTA 0°	HTL 40°	HTN 50°	HTR 65°	HTT 80°	HTV 95°	HTJ 110°	CODE	D mm	Capacity at different pressure values							(l/min) (bar)
									0.5	1.0	1.5	2.0	3.0	5.0	7.0	

#### LOW CAPACITY TIPS

•	•	•	•	•	•	•	•	0260	0.53	0.11	0.15	0.18	0.21	0.26	0.34	0.40	0.47
•	•	•	•	•	•	•	•	0390	0.66	0.16	0.23	0.28	0.32	0.39	0.50	0.60	0.71
•	•	•	•	•	•	•	•	0590	0.79	0.24	0.34	0.42	0.48	0.59	0.76	0.90	1.08
•	•	•	•	•	•	•	•	0780	0.91	0.32	0.45	0.55	0.64	0.78	1.01	1.19	1.42
•	•	•	•	•	•	•	•	1120	1.10	0.49	0.69	0.85	0.98	1.20	1.55	1.83	2.19
•	•	•	•	•	•	•	•	1160	1.30	0.65	0.92	1.13	1.31	1.60	2.07	2.44	2.92
•	•	•	•	•	•	•	•	1190	1.30	0.78	1.10	1.34	1.55	1.90	2.45	2.90	3.50
•	•	•	•	•	•	•	•	1200	1.40	0.82	1.15	1.41	1.63	2.00	2.58	3.06	3.65
•	•	•	•	•	•	•	•	1230	1.50	0.94	1.33	1.63	1.88	2.30	2.97	3.51	4.20

#### STANDARD CAPACITY TIPS

•	•	•	•	•	•	•	•	1310	1.70	1.27	1.79	2.19	2.53	3.10	4.00	4.74	5.66
•	•	•	•	•	•	•	•	1385	1.80	1.57	2.22	2.72	3.14	3.85	4.97	5.88	7.03
•	•	•	•	•	•	•	•	1490	2.10	2.00	2.83	3.46	4.00	4.90	6.33	7.48	8.95
•	•	•	•	•	•	•	•	1581	2.30	2.37	3.35	4.11	4.74	5.81	7.50	8.87	10.6
•	•	•	•	•	•	•	•	1780	2.70	3.18	4.50	5.52	6.37	7.80	10.1	11.9	14.2
•	•	•	•	•	•	•	•	1980	3.00	4.00	5.66	6.93	8.00	9.80	12.7	15.0	17.9
•	•	•	•	•	•	•	•	2124	3.40	5.06	7.16	8.77	10.1	12.4	16.0	18.9	22.6
•	•	•	•	•	•	•	•	2153	3.80	6.25	8.83	10.8	12.5	15.3	19.8	23.4	27.9
•	•	•	•	•	•	•	•	2194	4.30	7.96	11.3	13.8	15.9	19.5	25.2	29.8	35.6

#### HIGH CAPACITY TIPS

•	•	•	•	•	•	•	•	2310	5.40	12.7	17.9	21.9	25.3	31.0	40.0	47.4	56.6
•	•	•	•	•	•	•	•	2390	6.00	15.9	22.5	27.6	31.8	39.0	50.3	59.6	71.2
•	•	•	•	•	•	•	•	2470	6.60	19.2	27.1	33.2	38.4	47.0	60.7	71.8	85.8
•	•	•	•	•	•	•	•	2590	7.50	24.1	34.1	41.7	48.2	59.0	76.2	90.1	108
•	•	•	•	•	•	•	•	2780	8.70	31.8	45.0	55.2	63.7	78.0	101	119	142

#### ACCESSORIES

We offer various specification and materials of nipples. Please see below ordering code

Name	Thread (RG) inch	Standard size	Large size	H mm	WS mm	D mm
Male nipple	1/4"	ZHS 0025 xxQ1	-	29	22	-
	3/8"	ZHS 0038 xxQ1	-	29	22	-
	1/2"	-	ZHS 0050 xxQ2	35	30	-
Female nipple	3/8"	ZHT 0038 xxQ1	-	29	22	-
Welding nipple	-	ZHU 0038 xxQ1	ZHU 0050 xxQ2	32	-	28
Seal (Viton) for SS nipples	-	VDH BQ10 E7	VDH BQ20 E7	-	-	-
GSeal (BUNA) for brass nipples	-	VDH BQ10 E8	VDH BQ20 E8	-	-	-

#### TYPICAL APPLICATIONS

- Washing:**  
Steel and PCB cleaning  
Filter cloth cleaning
- Cooling:**  
Steel cooling  
Product cooling
- Other applications:**  
Pre-treatment for coating process  
Sewage treatment system

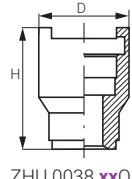
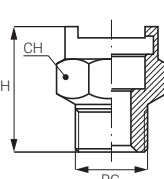

ZHS 0025 xxQ1



ZHS 0050 xxQ2

#### HOW TO MAKE UP THE NOZZLE CODE

Ex.: HTA 1310 B1

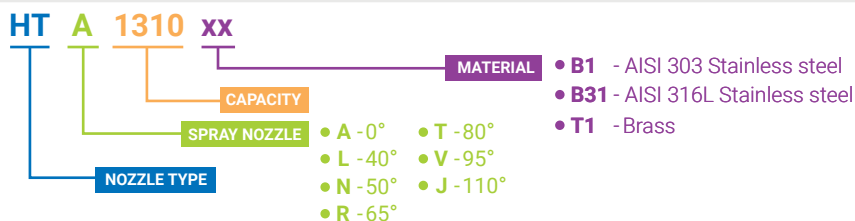

( LOW FLOW FLAT FAN NOZZLES ) J

LOW FLOW FLAT FAN NOZZLES

These standard flat fan nozzles are available in a wide range of capacities, spray angles and materials. Nozzles shown on this page cover the low to minimal capacity range from 0.06 to 1.60 litres per minute. The tiny outlet orifices, machined with high precision, may require to be protected from clogging by means of an adequate filter positioned inside the supply line, depending upon the quantity and type of the solid particles suspended in the liquid. These nozzles can be made with a customized inner thread for a VEF filter (\*optional). We suggest to buy these nozzles with their related VEF filter.

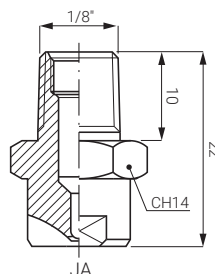
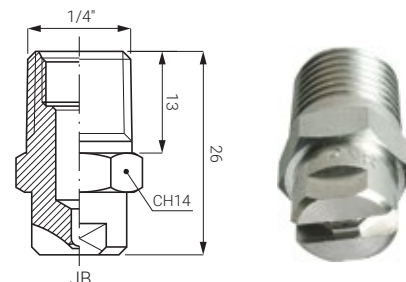

THREAD SPECIFICATION: BSPT, NPT  
 TYPICAL APPLICATIONS  
 Washing: steel and PCB cleaning, glass substrate cleaning  
 Cooling: steel cooling, product cooling  
 Other applications: pre-treatment for coating process, sewage treatment system

J nozzles series are also available with NPT thread: the code becomes H.



Spray section

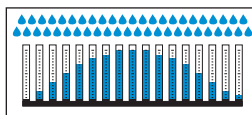

Convex distribution

Spray angle	25°	40°	50°	65°	75°	80°	95°	110°	CAPACITY CODE	D mm	Capacity at different pressure values (l/min) (bar)							
	1/8"	JAD	JAL	JAN	JAR	JAS	JAT	JAV			JAJ	0.7	1.0	1.5	2.0	3.0	5.0	7.0
1/4"	JBD	JBL	JBN	JBR	JBS	JBT	JBV	JB										
0100				•					0100	0.34	0.048	0.06	0.07	0.08	0.10	0.13	0.15	0.18
0130				•					0130	0.38	0.06	0.08	0.09	0.11	0.13	0.17	0.20	0.24
0150	•	•	•	•	•	•	•	•	0150	0.40	0.07	0.09	0.11	0.12	0.15	0.19	0.23	0.27
0200	•	•	•	•	•	•	•	•	0200	0.46	0.096	0.12	0.14	0.16	0.20	0.26	0.31	0.37
0260	•	•	•	•	•	•	•	•	0260	0.53	0.10	0.15	0.18	0.21	0.26	0.34	0.40	0.47
0390	•	•	•	•	•	•	•	•	0390	0.66	0.19	0.23	0.28	0.32	0.39	0.50	0.60	0.71
0590	•	•	•	•	•	•	•	•	0590	0.79	0.28	0.34	0.42	0.48	0.59	0.76	0.90	1.08

LIMIT OF MATERIALS PROCESSING

Hard materials such as stainless steel are extremely difficult to work with small profile drills, therefore not all nozzle sizes are available in all materials. Our sales office will offer you the best choice according to the materials and specifications you require.

Material	0100	0130	0150	0200	0260	0390	0590	0780
B31 - AISI 316L				•	•	•	•	•(1)
B1 - AISI 303	•	•	•	•	•	•	•	•(2)
T1 - Brass	•	•	•	•	•	•	•	•(2)

- (1) Low capacity body
- (2) Standard capacity body

VEF THREADED FILTERS (OPTIONAL)

J series small capacity nozzles have a small diameter and can work with clean liquids. So, if you order small capacity nozzles, we suggest you to order VEF threaded filters too, to avoid clogging.

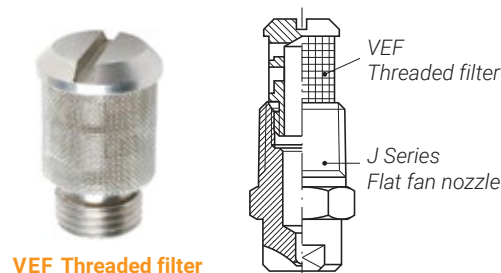

Nozzle type	Thread filter code	Thread size
JA (1/8")	VEF 0411 xx	M7
JB (1/4")	VEF 0138 xx	3/8"UNF

HOW TO MAKE UP THE NOZZLE CODE

Ex.: JAD 0130 B1

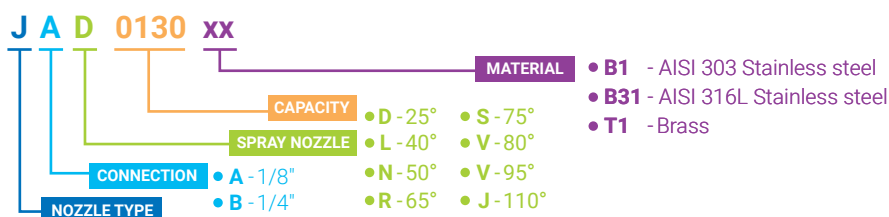

# J ( STANDARD CAPACITY FLAT FAN NOZZLES )

## STANDARD CAPACITY FLAT FAN NOZZLES

Standard flat fan nozzles are available in a wide range of different capacities, spray angles, thread sizes and materials. Used in several industrial applications, they produce a mist spray and supply an appropriate force of impact.

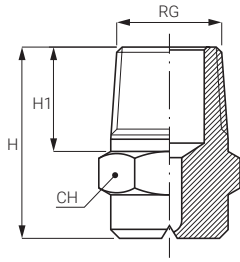

### TYPICAL APPLICATIONS

- Washing:* parts cleaning, food cleaning, filter cloth cleaning
  - Spray:* spray of chemicals, disinfectant and lubricating fluids
  - Cooling:* metal parts and vehicles cooling
  - Other applications:* water curtain for toxic gases separation, cleaning systems
- In steelworks they are used in the pickling process to remove surface oxides layers formed during the hot metalwork.

THREAD SPECIFICATION: BSPT, NPT

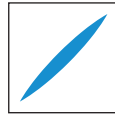

Spray section

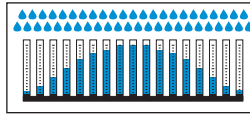

Convex distribution



### SPRAY ANGLE CODES

JxA	0°
JxC	20°
JxF	30°
JxM	45°
JxQ	60°
JxU	90°
JxW	120°

### THREAD SIZE CODES (RG)

JA	1/8"
JB	1/4"
JC	3/8"

SPRAY ANGLE	JAA 1/8"	JBA 1/4"	JCA 3/8"	CAPACITY CODE	D mm	Capacity at different pressure values							(l/min) (bar)	
						0.5	1.0	2.0	3.0	4.0	5.0	7.0	10	20
0°	•	•		0780	0.91	0.32	0.45	0.64	0.78	0.90	1.01	1.19	1.42	2.01
	•	•		1120	1.10	0.49	0.69	0.98	1.20	1.39	1.55	1.83	2.19	3.10
	•	•		1160	1.30	0.65	0.92	1.31	1.60	1.85	2.07	2.44	2.92	4.13
	•	•		1190	1.30	0.78	1.10	1.55	1.90	2.19	2.45	2.90	3.47	4.91
	•	•		1233	1.50	0.95	1.35	1.90	2.33	2.69	3.01	3.56	4.25	6.02
	•	•		1310	1.70	1.27	1.79	2.53	3.10	3.58	4.00	4.74	5.66	8.00
	•	•		1385	1.80	1.57	2.22	3.14	3.85	4.45	4.97	5.88	7.03	9.94
	•	•		1490	2.10	2.00	2.83	4.00	4.90	5.66	6.33	7.48	8.95	12.7
	•	•		1581	2.30	2.37	3.35	4.74	5.81	6.71	7.50	8.87	10.6	15.0
	•	•	•	1780	2.70	3.18	4.50	6.37	7.80	9.01	10.1	11.9	14.2	20.1
	•	•	•	1980	3.00	4.00	5.66	8.00	9.80	11.3	12.7	15.0	17.9	25.3
	•	•	•	2124	3.40	5.06	7.16	10.1	12.4	14.3	16.0	18.9	22.6	32.0
	•	•	•	2153	3.80	6.25	8.83	12.5	15.3	17.7	19.8	23.4	27.9	39.5
	•	•	•	2195	4.30	7.96	11.3	15.9	19.5	22.5	25.2	29.8	35.6	50.3
•	•	•	2245	4.80	10.0	14.1	20.0	24.5	28.3	31.6	37.4	44.7	63.3	
•	•	•	2274	5.20	11.2	15.8	22.4	27.4	31.6	35.4	41.9	50.0	70.7	
•	•	•	2310	5.40	12.7	17.9	25.3	31.0	35.8	40.0	47.4	56.6	80.0	
•	•	•	2390	6.00	15.9	22.5	31.8	39.0	45.0	50.3	59.6	71.2	101	
•	•	•	2470	6.20	19.2	27.1	38.4	47.0	54.3	60.7	71.8	85.8	121	

### DIMENSIONS AND WEIGHTS

CODE	Dimension (RG)	H	H1	CH	W
Type	inch	mm	mm	mm	gr
JA	1/8"	19.5	11	12	9
JB	1/4"	22.0	12	14	18
JC	3/8"	25.0	14	17	34

### IMPORTANT

The nozzle **Jxx 0780 B31** is made with "low capacity" body, while when it's fabricated with other materials is made with "standard capacity" body.

### HOW TO MAKE UP THE NOZZLE CODE

Ex.: JAA 1153 B1

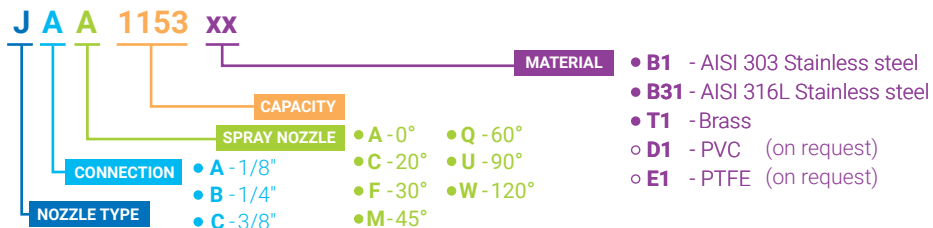



( STANDARD CAPACITY FLAT FAN NOZZLES ) J

D	Capacity at different pressure values (l/min) (bar)	0.5	1.0	2.0	3.0	4.0	5.0	7.0	10	20	
											JAC 1/8"
20°	• • • • • • • • • • • • • • • •	0.91	0.32	0.45	0.64	0.78	0.90	1.01	1.19	1.42	2.01
	• • • • • • • • • • • • • • • •	1.10	0.49	0.69	0.98	1.20	1.39	1.55	1.83	2.19	3.10
	• • • • • • • • • • • • • • • •	1.30	0.65	0.92	1.31	1.60	1.85	2.07	2.44	2.92	4.13
	• • • • • • • • • • • • • • • •	1.30	0.78	1.10	1.55	1.90	2.19	2.45	2.90	3.47	4.91
	• • • • • • • • • • • • • • • •	1.50	0.95	1.35	1.90	2.33	2.69	3.01	3.56	4.25	6.02
	• • • • • • • • • • • • • • • •	1.70	1.27	1.79	2.53	3.10	3.58	4.00	4.74	5.66	8.00
	• • • • • • • • • • • • • • • •	1.80	1.57	2.22	3.14	3.85	4.45	4.97	5.88	7.03	9.94
	• • • • • • • • • • • • • • • •	2.10	2.00	2.83	4.00	4.90	5.66	6.33	7.48	8.95	12.7
	• • • • • • • • • • • • • • • •	2.30	2.37	3.35	4.74	5.81	6.71	7.50	8.87	10.6	15.0
	• • • • • • • • • • • • • • • •	2.70	3.18	4.50	6.37	7.80	9.01	10.1	11.9	14.2	20.1
	• • • • • • • • • • • • • • • •	3.00	4.00	5.66	8.00	9.80	11.3	12.7	15.0	17.9	25.3
	• • • • • • • • • • • • • • • •	3.40	5.06	7.16	10.1	12.4	14.3	16.0	18.9	22.6	32.0
	• • • • • • • • • • • • • • • •	3.80	6.25	8.83	12.5	15.3	17.7	19.8	23.4	27.9	39.5
	• • • • • • • • • • • • • • • •	4.30	7.96	11.3	15.9	19.5	22.5	25.2	29.8	35.6	50.3
	• • • • • • • • • • • • • • • •	4.80	10.0	14.1	20.0	24.5	28.3	31.6	37.4	44.7	63.3
	• • • • • • • • • • • • • • • •	5.20	11.2	15.8	22.4	27.4	31.6	35.4	41.9	50.0	70.7
• • • • • • • • • • • • • • • •	5.40	12.7	17.9	25.3	31.0	35.8	40.0	47.4	56.6	80.0	
• • • • • • • • • • • • • • • •	6.00	15.9	22.5	31.8	39.0	45.0	50.3	59.6	71.2	101	
• • • • • • • • • • • • • • • •	6.20	19.2	27.1	38.4	47.0	54.3	60.7	71.8	85.8	121	

SPRAY ANGLE CODES

JxA	0°
JxC	20°
JxF	30°
JxM	45°
JxQ	60°
JxU	90°
JxW	120°

THREAD SIZE CODES (RG)

JA	1/8"
JB	1/4"
JC	3/8"

IMPORTANT

The nozzle **Jxx 0780 B31** is made with "low capacity" body, while when it's fabricated with other materials is made with "standard capacity" body.

D	Capacity at different pressure values (l/min) (bar)	0.5	1.0	2.0	3.0	4.0	5.0	7.0	10	20	
											JAF
30°	• • • • • • • • • • • • • • • •	0.91	0.32	0.45	0.64	0.78	0.90	1.01	1.19	1.42	2.01
	• • • • • • • • • • • • • • • •	1.10	0.49	0.69	0.98	1.20	1.39	1.55	1.83	2.19	3.10
	• • • • • • • • • • • • • • • •	1.30	0.65	0.92	1.31	1.60	1.85	2.07	2.44	2.92	4.13
	• • • • • • • • • • • • • • • •	1.30	0.78	1.10	1.55	1.90	2.19	2.45	2.90	3.47	4.91
	• • • • • • • • • • • • • • • •	1.50	0.95	1.35	1.90	2.33	2.69	3.01	3.56	4.25	6.02
	• • • • • • • • • • • • • • • •	1.70	1.27	1.79	2.53	3.10	3.58	4.00	4.74	5.66	8.00
	• • • • • • • • • • • • • • • •	1.80	1.57	2.22	3.14	3.85	4.45	4.97	5.88	7.03	9.94
	• • • • • • • • • • • • • • • •	2.10	2.00	2.83	4.00	4.90	5.66	6.33	7.48	8.95	12.7
	• • • • • • • • • • • • • • • •	2.30	2.37	3.35	4.74	5.81	6.71	7.50	8.87	10.6	15.0
	• • • • • • • • • • • • • • • •	2.70	3.18	4.50	6.37	7.80	9.01	10.1	11.9	14.2	20.1
	• • • • • • • • • • • • • • • •	3.00	4.00	5.66	8.00	9.80	11.3	12.7	15.0	17.9	25.3
	• • • • • • • • • • • • • • • •	3.40	5.06	7.16	10.1	12.4	14.3	16.0	18.9	22.6	32.0
	• • • • • • • • • • • • • • • •	3.80	6.25	8.83	12.5	15.3	17.7	19.8	23.4	27.9	39.5
	• • • • • • • • • • • • • • • •	4.30	7.96	11.3	15.9	19.5	22.5	25.2	29.8	35.6	50.3
	• • • • • • • • • • • • • • • •	4.80	10.0	14.1	20.0	24.5	28.3	31.6	37.4	44.7	63.3
	• • • • • • • • • • • • • • • •	5.20	11.2	15.8	22.4	27.4	31.6	35.4	41.9	50.0	70.7
• • • • • • • • • • • • • • • •	5.40	12.7	17.9	25.3	31.0	35.8	40.0	47.4	56.6	80.0	
• • • • • • • • • • • • • • • •	6.00	15.9	22.5	31.8	39.0	45.0	50.3	59.6	71.2	101	
• • • • • • • • • • • • • • • •	6.20	19.2	27.1	38.4	47.0	54.3	60.7	71.8	85.8	121	

D	Capacity at different pressure values (l/min) (bar)	0.5	1.0	2.0	3.0	4.0	5.0	7.0	10	20	
											JAM
45°	• • • • • • • • • • • • • • • •	0.91	0.32	0.45	0.64	0.78	0.90	1.01	1.19	1.42	2.01
	• • • • • • • • • • • • • • • •	1.10	0.49	0.69	0.98	1.20	1.39	1.55	1.83	2.19	3.10
	• • • • • • • • • • • • • • • •	1.30	0.65	0.92	1.31	1.60	1.85	2.07	2.44	2.92	4.13
	• • • • • • • • • • • • • • • •	1.30	0.78	1.10	1.55	1.90	2.19	2.45	2.90	3.47	4.91
	• • • • • • • • • • • • • • • •	1.50	0.95	1.35	1.90	2.33	2.69	3.01	3.56	4.25	6.02
	• • • • • • • • • • • • • • • •	1.70	1.27	1.79	2.53	3.10	3.58	4.00	4.74	5.66	8.00
	• • • • • • • • • • • • • • • •	1.80	1.57	2.22	3.14	3.85	4.45	4.97	5.88	7.03	9.94
	• • • • • • • • • • • • • • • •	2.10	2.00	2.83	4.00	4.90	5.66	6.33	7.48	8.95	12.7
	• • • • • • • • • • • • • • • •	2.30	2.37	3.35	4.74	5.81	6.71	7.50	8.87	10.6	15.0
	• • • • • • • • • • • • • • • •	2.70	3.18	4.50	6.37	7.80	9.01	10.1	11.9	14.2	20.1
	• • • • • • • • • • • • • • • •	3.00	4.00	5.66	8.00	9.80	11.3	12.7	15.0	17.9	25.3
	• • • • • • • • • • • • • • • •	3.40	5.06	7.16	10.1	12.4	14.3	16.0	18.9	22.6	32.0
	• • • • • • • • • • • • • • • •	3.80	6.25	8.83	12.5	15.3	17.7	19.8	23.4	27.9	39.5
	• • • • • • • • • • • • • • • •	4.30	7.96	11.3	15.9	19.5	22.5	25.2	29.8	35.6	50.3
	• • • • • • • • • • • • • • • •	4.80	10.0	14.1	20.0	24.5	28.3	31.6	37.4	44.7	63.3
	• • • • • • • • • • • • • • • •	5.20	11.2	15.8	22.4	27.4	31.6	35.4	41.9	50.0	70.7
• • • • • • • • • • • • • • • •	5.40	12.7	17.9	25.3	31.0	35.8	40.0	47.4	56.6	80.0	
• • • • • • • • • • • • • • • •	6.00	15.9	22.5	31.8	39.0	45.0	50.3	59.6	71.2	101	
• • • • • • • • • • • • • • • •	6.20	19.2	27.1	38.4	47.0	54.3	60.7	71.8	85.8	121	

HOW TO MAKE UP THE NOZZLE CODE

Ex.: JAC 1153 B1

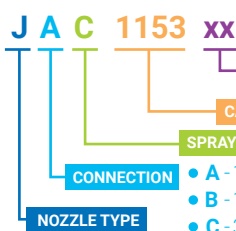

- B1 - AISI 303 Stainless steel
- B31 - AISI 316L Stainless steel
- T1 - Brass
- D1 - PVC (on request)
- E1 - PTFE (on request)

# J ( STANDARD CAPACITY FLAT FAN NOZZLES )

SPRAY ANGLE CODES

JxA	0°
JxC	20°
JxF	30°
JxM	45°
JxQ	60°
JxU	90°
JxW	120°

THREAD SIZE CODES (RG)

JA	1/8"
JB	1/4"
JC	3/8"

SPRAY ANGLE	JAQ 1/8"	JBQ 1/4"	JCQ 3/8"	CAPACITY CODE	D mm	Capacity at different pressure values (l/min) (bar)									
						0.5	1.0	2.0	3.0	4.0	5.0	7.0	10	20	
60°	•	•		0780	0.91	0.32	0.45	0.64	0.78	0.90	1.01	1.19	1.42	2.01	
	•	•		1120	1.10	0.49	0.69	0.98	1.20	1.39	1.55	1.83	2.19	3.10	
	•	•		1160	1.30	0.65	0.92	1.31	1.60	1.85	2.07	2.44	2.92	4.13	
	•	•		1190	1.30	0.78	1.10	1.55	1.90	2.19	2.45	2.90	3.47	4.91	
	•	•		1233	1.50	0.95	1.35	1.90	2.33	2.69	3.01	3.56	4.25	6.02	
	•	•		1310	1.70	1.27	1.79	2.53	3.10	3.58	4.00	4.74	5.66	8.00	
	•	•		1385	1.80	1.57	2.22	3.14	3.85	4.45	4.97	5.88	7.03	9.94	
	•	•		1490	2.10	2.00	2.83	4.00	4.90	5.66	6.33	7.48	8.95	12.7	
	•	•		1581	2.30	2.37	3.35	4.74	5.81	6.71	7.50	8.87	10.6	15.0	
	•	•	•	1780	2.70	3.18	4.50	6.37	7.80	9.01	10.1	11.9	14.2	20.1	
	•	•	•	1980	3.00	4.00	5.66	8.00	9.80	11.3	12.7	15.0	17.9	25.3	
	•	•	•	2124	3.40	5.06	7.16	10.1	12.4	14.3	16.0	18.9	22.6	32.0	
	•	•	•	2153	3.80	6.25	8.83	12.5	15.3	17.7	19.8	23.4	27.9	39.5	
	•	•	•	2195	4.30	7.96	11.3	15.9	19.5	22.5	25.2	29.8	35.6	50.3	
	•	•	•	2245	4.80	10.0	14.1	20.0	24.5	28.3	31.6	37.4	44.7	63.3	
	•	•	•	2274	5.20	11.2	15.8	22.4	27.4	31.6	35.4	41.9	50.0	70.7	
	•	•	•	2310	5.40	12.7	17.9	25.3	31.0	35.8	40.0	47.4	56.6	80.0	
•	•	•	2390	6.00	15.9	22.5	31.8	39.0	45.0	50.3	59.6	71.2	101		
•	•	•	2470	6.20	19.2	27.1	38.4	47.0	54.3	60.7	71.8	85.8	121		

**IMPORTANT**

The nozzle **Jxx 0780 B31** is made with "low capacity" body, while when it's fabricated with other materials is made with "standard capacity" body.

SPRAY ANGLE	JAU	JBU	JCU	CODE	D	0.5	1.0	2.0	3.0	4.0	5.0	7.0	10	20
90°	•	•		0780	0.91	0.32	0.45	0.64	0.78	0.90	1.01	1.19	1.42	2.01
	•	•		1120	1.10	0.49	0.69	0.98	1.20	1.39	1.55	1.83	2.19	3.10
	•	•		1160	1.30	0.65	0.92	1.31	1.60	1.85	2.07	2.44	2.92	4.13
	•	•		1190	1.30	0.78	1.10	1.55	1.90	2.19	2.45	2.90	3.47	4.91
	•	•		1233	1.50	0.95	1.35	1.90	2.33	2.69	3.01	3.56	4.25	6.02
	•	•		1310	1.70	1.27	1.79	2.53	3.10	3.58	4.00	4.74	5.66	8.00
	•	•		1385	1.80	1.57	2.22	3.14	3.85	4.45	4.97	5.88	7.03	9.94
	•	•		1490	2.10	2.00	2.83	4.00	4.90	5.66	6.33	7.48	8.95	12.7
	•	•		1581	2.30	2.37	3.35	4.74	5.81	6.71	7.50	8.87	10.6	15.0
	•	•	•	1780	2.70	3.18	4.50	6.37	7.80	9.01	10.1	11.9	14.2	20.1
	•	•	•	1980	3.00	4.00	5.66	8.00	9.80	11.3	12.7	15.0	17.9	25.3
	•	•	•	2124	3.40	5.06	7.16	10.1	12.4	14.3	16.0	18.9	22.6	32.0
	•	•	•	2153	3.80	6.25	8.83	12.5	15.3	17.7	19.8	23.4	27.9	39.5
	•	•	•	2195	4.30	7.96	11.3	15.9	19.5	22.5	25.2	29.8	35.6	50.3
	•	•	•	2245	4.80	10.0	14.1	20.0	24.5	28.3	31.6	37.4	44.7	63.3
	•	•	•	2274	5.20	11.2	15.8	22.4	27.4	31.6	35.4	41.9	50.0	70.7
	•	•	•	2310	5.40	12.7	17.9	25.3	31.0	35.8	40.0	47.4	56.6	80.0
•	•	•	2390	6.00	15.9	22.5	31.8	39.0	45.0	50.3	59.6	71.2	101	
•	•	•	2470	6.20	19.2	27.1	38.4	47.0	54.3	60.7	71.8	85.8	121	

SPRAY ANGLE	JAW	JBW	JCW	CODE	D	0.5	1.0	2.0	3.0	4.0	5.0	7.0	10	20
120°	•	•		0780	0.91	0.32	0.45	0.64	0.78	0.90	1.01	1.19	1.42	2.01
	•	•		1120	1.10	0.49	0.69	0.98	1.20	1.39	1.55	1.83	2.19	3.10
	•	•		1160	1.30	0.65	0.92	1.31	1.60	1.85	2.07	2.44	2.92	4.13
	•	•		1190	1.30	0.78	1.10	1.55	1.90	2.19	2.45	2.90	3.47	4.91
	•	•		1233	1.50	0.95	1.35	1.90	2.33	2.69	3.01	3.56	4.25	6.02
	•	•		1310	1.70	1.27	1.79	2.53	3.10	3.58	4.00	4.74	5.66	8.00
	•	•		1385	1.80	1.57	2.22	3.14	3.85	4.45	4.97	5.88	7.03	9.94
	•	•		1490	2.10	2.00	2.83	4.00	4.90	5.66	6.33	7.48	8.95	12.7
	•	•		1581	2.30	2.37	3.35	4.74	5.81	6.71	7.50	8.87	10.6	15.0
	•	•	•	1780	2.70	3.18	4.50	6.37	7.80	9.01	10.1	11.9	14.2	20.1
	•	•	•	1980	3.00	4.00	5.66	8.00	9.80	11.3	12.7	15.0	17.9	25.3
	•	•	•	2124	3.40	5.06	7.16	10.1	12.4	14.3	16.0	18.9	22.6	32.0
	•	•	•	2153	3.80	6.25	8.83	12.5	15.3	17.7	19.8	23.4	27.9	39.5
	•	•	•	2195	4.30	7.96	11.3	15.9	19.5	22.5	25.2	29.8	35.6	50.3
	•	•	•	2245	4.80	10.0	14.1	20.0	24.5	28.3	31.6	37.4	44.7	63.3
	•	•	•	2274	5.20	11.2	15.8	22.4	27.4	31.6	35.4	41.9	50.0	70.7
	•	•	•	2310	5.40	12.7	17.9	25.3	31.0	35.8	40.0	47.4	56.6	80.0
•	•	•	2390	6.00	15.9	22.5	31.8	39.0	45.0	50.3	59.6	71.2	101	
•	•	•	2470	6.20	19.2	27.1	38.4	47.0	54.3	60.7	71.8	85.8	121	

**HOW TO MAKE UP THE NOZZLE CODE**

Ex.: JAA 1153 B1

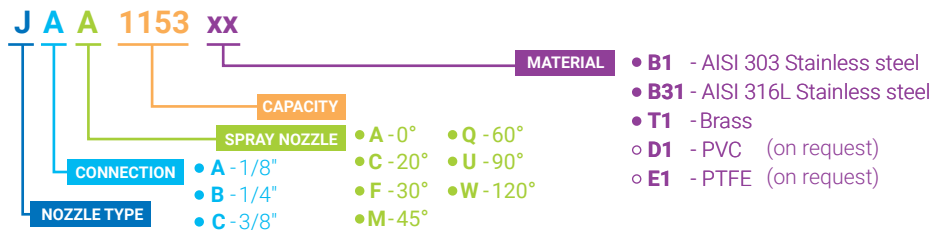

# ( LARGE CAPACITY FLAT FAN NOZZLES ) J

## LARGE CAPACITY FLAT FAN NOZZLES

J series standard flat fan nozzles are available in a wide range of different capacities, spray angles, thread sizes and materials. The large capacity models produce a high-impact spray jet with a mist effect and a powerful washing action.



THREAD SPECIFICATION: BSPT, NPT



Spray section

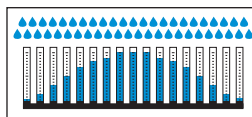

Convex distribution

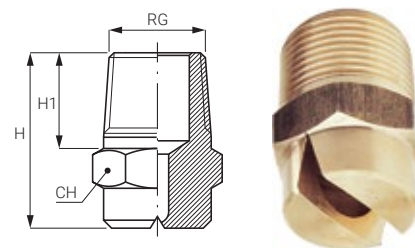

Spray Angle	1/2"	3/4"	1"	CODE	Capacity at different pressure values (l/min) (bar)									
					0.5	1.0	2.0	3.0	4.0	5.0	7.0	10	20	
0°	•			JDA 2590 xx	24.1	34.1	48.2	59.0	68.1	76.2	90.1	108	152	
	•			JDA 2780 xx	31.8	45.0	63.7	78.0	90.1	101	119	142	201	
		•		JEA 3134 xx	54.7	77.4	109	134	155	173	205	245	346	
		•		JEA 3275 xx	112	159	225	275	318	355	420	502	710	
			•	JFA 3390 xx	159	225	318	390	450	503	596	712	1007	
15°			•	JFA 3435 xx	178	251	355	435	502	562	664	794	1123	
	•			JDB 2195 xx	7.96	11.3	15.9	19.5	22.5	25.2	29.8	35.6	50.3	
	•			JDB 2274 xx	11.2	15.8	22.4	27.4	31.6	35.4	41.9	50.0	70.7	
25°		•		JDB 2390 xx	15.9	22.5	31.8	39.0	45.0	50.3	59.6	71.2	101	
	•			JEB 2990 xx	40.4	57.2	80.8	99.0	114	128	151	181	256	
	•			JDD 2390 xx	15.9	22.5	31.8	39.0	45.0	50.3	59.6	71.2	101	
	•			JDD 2590 xx	24.1	34.1	48.2	59.0	68.1	76.2	90.1	108	152	
40°			•	JDD 2780 xx	31.8	45.0	63.7	78.0	90.1	101	119	142	201	
	•			JFD 3195 xx	79.6	113	159	195	225	252	298	356	503	
	•			JDL 2195 xx	7.96	11.3	15.9	19.5	22.5	25.2	29.8	35.6	50.3	
	•			JDL 2240 xx	9.80	13.9	19.6	24.0	27.7	31.0	36.7	43.8	62.0	
	•			JDL 2274 xx	11.2	15.8	22.4	27.4	31.6	35.4	41.9	50.0	70.7	
50°			•	JDL 2390 xx	15.9	22.5	31.8	39.0	45.0	50.3	59.6	71.2	101	
	•			JDL 2590 xx	24.1	34.1	48.2	59.0	68.1	76.2	90.1	108	152	
	•			JDN 2274 xx	11.2	15.8	22.4	27.4	31.6	35.4	41.9	50.0	70.7	
	•			JDN 2390 xx	15.9	22.5	31.8	39.0	45.0	50.3	59.6	71.2	101	
	•			JDN 2590 xx	24.1	34.1	48.2	59.0	68.1	76.2	90.1	108	152	
65°		•		JDN 2780 xx	31.8	45.0	63.7	78.0	90.1	101	119	142	201	
			•	JEN 3158 xx	64.5	91.2	129	158	182	204	241	288	408	
	•			JFN 3195 xx	79.6	113	159	195	225	252	298	356	503	
	•			JFN 3230 xx	93.9	133	188	230	266	297	351	420	594	
80°	•			JDR 2195 xx	7.96	11.3	15.9	19.5	22.5	25.2	29.8	35.6	50.3	
	•			JDR 2240 xx	9.80	13.9	19.6	24.0	27.7	31.0	36.7	43.8	62.0	
	•			JDR 2274 xx	11.2	15.8	22.4	27.4	31.6	35.4	41.9	50.0	70.7	
	•			JDR 2390 xx	15.9	22.5	31.8	39.0	45.0	50.3	59.6	71.2	101	
	•			JDR 2590 xx	24.1	34.1	48.2	59.0	68.1	76.2	90.1	108	152	
95°			•	JFR 2780 xx	31.8	45.0	63.7	78.0	90.1	101	119	142	201	
	•			JDT 2195 xx	7.96	11.3	15.9	19.5	22.5	25.2	29.8	35.6	50.3	
	•			JDT 2240 xx	9.80	13.9	19.6	24.0	27.7	31.0	36.7	43.8	62.0	
	•			JDT 2274 xx	11.2	15.8	22.4	27.4	31.6	35.4	41.9	50.0	70.7	
	•			JDT 2390 xx	15.9	22.5	31.8	39.0	45.0	50.3	59.6	71.2	101	

### SPRAY ANGLE CODES

NOZZLE CODE	SPRAY ANGLE
JDA	0°
JDB	15°
JDD	25°
JDL	40°
JDN	50°
JDR	65°
JDT	80°
JDV	95°

### DIMENSIONS AND WEIGHTS

Below are dimensions and specifications for use.

CODE	Dim.	H	H1	WS	W
	inch	mm	mm	mm	gr
JD	1/2"	33	17	22	65
JE	3/4"	41	20	27	130
JF	1"	61	22	27	215

### TYPICAL APPLICATIONS

*Washing:* tanks, large parts and vehicles cleaning  
*Spray:* spray of chemicals, disinfectants and lubricating fluids  
*Cooling:* parts cooling, steel cooling  
*Other applications:* water curtain to separate toxic gases, fire-fighting systems

### HOW TO MAKE UP THE NOZZLE CODE

Ex.: JDA 2590 B1

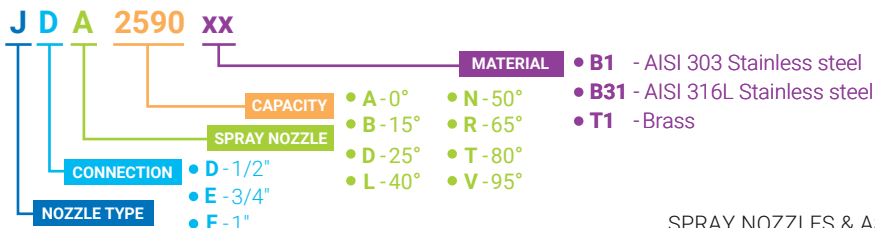

# K ( FLAT FAN NOZZLES / LARGE SPRAY ANGLE )

## LARGE SPRAY ANGLE

K flat fan nozzles work on the deflection principle conveying a water vein onto a machined deflection surface, and produce a jet with a wide angle flat spray pattern, medium impact value and medium size droplets. Between their inlet orifice and spray orientation there is a 75° angle (see below). Their round outlet orifice and free inside passage minimize the risk of clogging. In addition, compared to standard flat fan nozzles working with a limited operating pressure, the K series models with large spray angles produce an excellent mist effect. These K nozzles are available with threaded connections, for capacities from 0390 and 3350, and also as tips to be assembled onto a nipple by means of a retaining nut. An alternative option are the KX types.

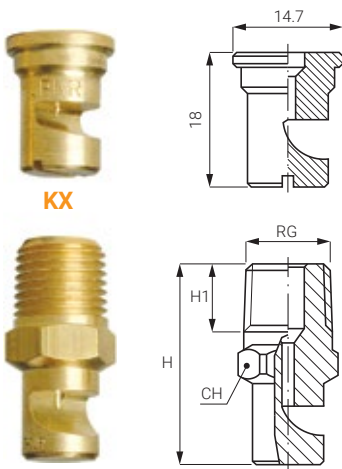

THREAD SPECIFICATION: BSPT, NPT

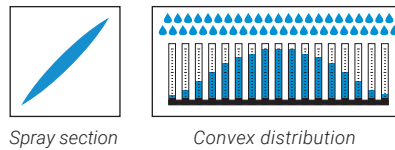

## THREAD SIZE AND DIMENSIONS

Here below please find available thread sizes and nozzles dimensions. Different capacities correspond to different deflection angles. The external dimensions may differ even if the thread size is the same. The table includes the largest nozzles with a given thread size.

CODE	RG inch	H mm	H1 mm	CH mm
KGW	1/8"	24,0 (from 0390 to 1120)	8,5	12
		25,0 (from 1160 to 1940)	9,0	
		31,0 (from 2117 to 2157)	10,0	
KHW	1/4"	31,0 (from 1160 to 1940)	12,5	14
		34,0 (from 2117 to 2210)		
KIW	3/8"	44,0 (all codes)	13,0	17
KJW	1/2"	49,0 (all codes)	17,0	22
KKW	3/4"	56,0 (from 2700 to 2940)	20,0	27
		65,0 (from 3110 to 3164)		36
KLW	1"	92,0 (all codes)	26,0	46

## ASSEMBLY FITTINGS

The below illustration shows the assembly of a KX nozzle tip (in the middle) with a nipple and a locknut.

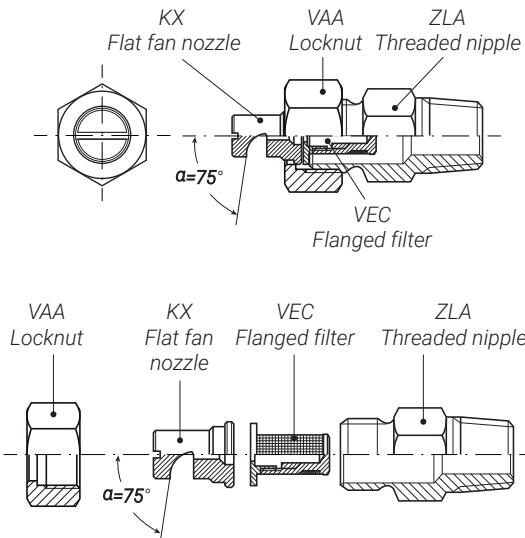

## Typical applications

- Washing: fruits, vegetables, crushed stones, other
- Spray: rolling oil, release agents, coolants
- Cooling: metal parts, bottles
- Other applications: foam dispersion, fire-fighting systems, water curtains

### HOW TO MAKE UP THE NOZZLE CODE

Ex.: KGW 0390 B1

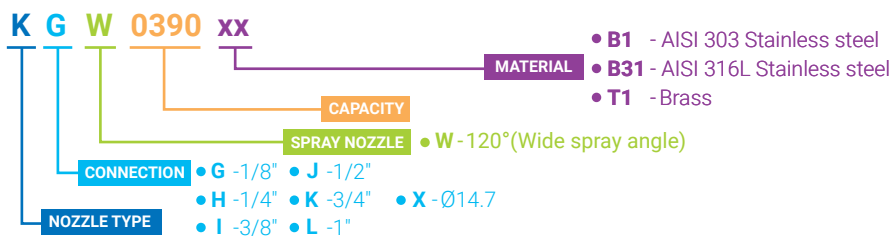





( FLAT FAN NOZZLES / LARGE SPRAY ANGLE ) **K**

LARGE SPRAY ANGLE

KGW 1/8"	KHW 1/4"	KIW 3/8"	KJW 1/2"	KKW 3/4"	KLW 1"	KXW	D mm	CODE	Capacity at different pressure values							Spray angle (°) at pressure (bar)	
									0.5	1.0	2.0	3.0	4.0	5.0	7.0	1.5	4.0
•						•	0.6	<b>0390</b>	0.16	0.23	0.32	0.39	0.45	0.50	0.60	90°	120°
•						•	0.7	<b>0590</b>	0.24	0.34	0.48	0.59	0.68	0.76	0.90	105°	120°
•						•	0.8	<b>0780</b>	0.32	0.45	0.64	0.78	0.90	1.01	1.19	110°	125°
•						•	1.0	<b>1120</b>	0.49	0.69	0.98	1.20	1.39	1.55	1.83	105°	122°
•	•					•	1.1	<b>1160</b>	0.65	0.92	1.31	1.60	1.85	2.07	2.44	110°	130°
•	•					•	1.3	<b>1200</b>	0.82	1.15	1.63	2.00	2.31	2.58	3.06	120°	130°
•	•					•	1.4	<b>1230</b>	0.94	1.33	1.88	2.30	2.66	2.97	3.51	110°	125°
•	•					•	1.6	<b>1310</b>	1.27	1.79	2.53	3.10	3.58	4.00	4.74	120°	130°
•	•					•	1.8	<b>1390</b>	1.59	2.25	3.18	3.90	4.50	5.03	5.96	130°	140°
•	•					•	2.3	<b>1590</b>	2.41	3.41	4.82	5.90	6.81	7.62	9.01	120°	130°
•	•					•	2.6	<b>1780</b>	3.18	4.50	6.37	7.80	9.01	10.1	11.9	130°	140°
•	•					•	2.9	<b>1940</b>	3.84	5.43	7.68	9.40	10.9	12.1	14.4	140°	150°
•	•					•	3.3	<b>2117</b>	4.78	6.75	9.55	11.7	13.5	15.1	17.9	110°	120°
•	•					•	3.6	<b>2141</b>	5.76	8.14	11.5	14.1	16.3	18.2	21.5	120°	130°
•	•					•	3.8	<b>2157</b>	6.41	9.06	12.8	15.7	18.1	20.3	24.0	120°	130°
	•					•	4.0	<b>2172</b>	7.02	9.93	14.0	17.2	19.9	22.2	26.3	125°	135°
	•					•	4.1	<b>2188</b>	7.68	10.9	15.4	18.8	21.7	24.3	28.7	130°	140°
	•					•	4.4	<b>2210</b>	8.57	12.1	17.1	21.0	24.2	27.1	32.1	135°	145°
		•				•	4.5	<b>2230</b>	9.39	13.3	18.8	23.0	26.6	29.7	35.1	110°	120°
		•				•	5.0	<b>2270</b>	11.0	15.6	22.0	27.0	31.2	34.9	41.2	115°	125°
		•	•			•	5.3	<b>2310</b>	12.7	17.9	25.3	31.0	35.8	40.0	47.4	125°	135°
		•	•				5.6	<b>2350</b>	14.3	20.2	28.6	35.0	40.4	45.2	53.5	130°	140°
			•				6.0	<b>2390</b>	15.9	22.5	31.8	39.0	45.0	50.3	59.6	130°	140°
			•				6.5	<b>2470</b>	19.2	27.1	38.4	47.0	54.3	60.7	71.8	135°	140°
			•				7.1	<b>2550</b>	22.5	31.8	44.9	55.0	63.5	71.0	84.0	135°	145°
			•				7.5	<b>2630</b>	25.7	36.4	51.4	63.0	72.7	81.3	96.2	140°	150°
				•			8.0	<b>2700</b>	28.6	40.4	57.2	70.0	80.8	90.4	107	130°	140°
				•			8.4	<b>2780</b>	31.8	45.0	63.7	78.0	90.1	101	119	135°	145°
				•			8.7	<b>2860</b>	35.1	49.7	70.2	86.0	99.3	111	131	135°	145°
				•			9.3	<b>2940</b>	38.4	54.3	76.8	94.0	109	121	144	140°	150°
				•			10.3	<b>3110</b>	44.9	63.5	89.8	110	127	142	168	125°	135°
				•			11.0	<b>3125</b>	51.0	72.2	102	125	144	161	191	130°	135°
				•			11.4	<b>3141</b>	57.6	81.4	115	141	163	182	215	130°	135°
				•			12.2	<b>3164</b>	67.0	94.7	134	164	189	212	251	135°	145°
					•		14.6	<b>3235</b>	95.9	136	192	235	271	303	359	130°	135°
					•		17.9	<b>3350</b>	143	202	286	350	404	452	535	130°	135°

ASSEMBLY FITTINGS

KX series nozzles are assembled with pipe clamp, welding nipple and locknut.  
Our assembly accessories are available in many different types and materials.

Name	Material code	Appearance	Model no.	
			3/8" Standard size	3/4" Large size
Locknut <i>P.90</i>	<b>B1</b> - AISI 303 <b>B31</b> - AISI 316L <b>T1</b> - Brass <b>D6</b> - Fiberglass reinforced PP		VAA 0380 <b>xxB</b>	VAA 0750 <b>xxB</b>
Welding nipple <i>P.91</i>	<b>B1</b> - AISI 303 <b>B31</b> - AISI 316L		ZAA C018 <b>xxG</b>	ZAA E027 <b>xxG</b>
Threaded nipple <i>P.91</i>	<b>B1</b> - AISI 303 <b>B31</b> - AISI 316L <b>T1</b> - Brass		ZLA 2538 <b>xxB</b>	ZLA 7575 <b>xxB</b>
Metal pipe clamp <i>P.89</i>	<b>B1</b> - AISI 303 <b>T1</b> - Brass		ZPM	-
Plastic pipe clamp <i>P.88</i>	<b>D6</b> - Fiberglass reinforced PP		ZPB 0050 D6	-



# K (FLAT FAN NOZZLES / HIGH IMPACT TYPES)

## HIGH IMPACT TYPES

The K series nozzles of this type are designed with a spoon-shaped deflected surface to concentrate the liquid flow and produce a narrow-angle flat fan spray with a high impact value. For this feature they are widely used in all working environments requiring powerful jets. Compared to the standard cat-eye-shaped flat fan nozzle tips, K nozzles have a larger and free inner passage and are less subject to clogging, provide high performance cleaning efficiency and have an extended operating life. They are designed with a specific angle (see ~ CL on the left drawing) between inlet orifice and spray orientation surface. These nozzles are available with standard male threads but also with quick coupling nipples to shorten maintenance time.

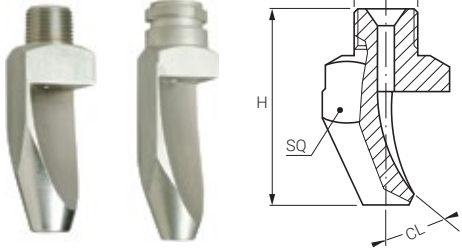

THREAD SPECIFICATION: BSPT, NPT

### TYPICAL APPLICATIONS

cleaning of parts, crushed stone, road, aircrafts, vehicles and tanks.



Spray section

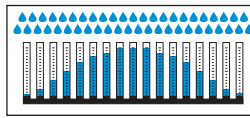

Convex distribution

### THREAD SIZE CODE

<b>KOx</b>	1/8"
<b>KPx</b>	1/4"
<b>KQx</b>	3/8"
<b>KRx</b>	1/2"
<b>KSx</b>	3/4"
<b>KTx</b>	QC

### QUICK COUPLING NIPPLES

Name	Thread size (RG) inch	Standard size	Large size	H mm	CH mm	DIA mm
Male nipple	1/4"	ZHS 0025 xxQ1	-	29	22	-
	3/8"	ZHS 0038 xxQ1	-	29	22	-
	1/2"	-	ZHS 0050 xxQ2	35	30	-
Female nipple	3/8"	ZHT 0038 xxQ1	-	29	22	-
Welding nipple	-	ZHU 0038 xxQ1	ZHU 0050 xxQ2	32	-	28
Seal (Viton) for SS nipple	-	VDH BQ10 E7	VDH BQ20 E7	-	-	-
Seal (BUNA) for brass nipple	-	VDH BQ10 E8	VDH BQ20 E8	-	-	-



ZHS + KTH



ZHS 0025 xxQ1



ZHS 0050 xxQ2

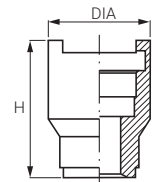
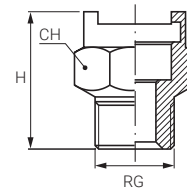

ZHU 0038 xxQ1

### HOW TO MAKE UP THE NOZZLE CODE

EX.: KPB 1390 B1

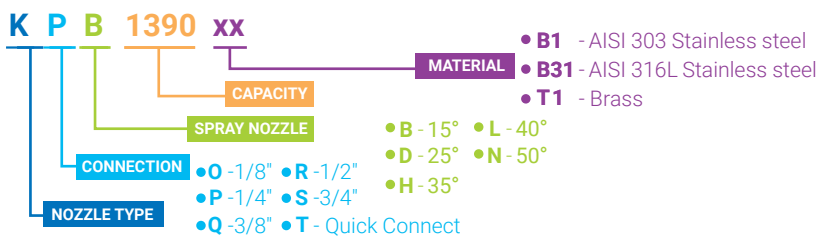

( FLAT FAN NOZZLES / HIGH IMPACT TYPES ) **K**

HIGH IMPACT TYPES

15°	1/8"	1/4"	3/8"	1/2"	3/4"	QC	CODE	D mm	Capacity at different pressure values (l/min) (bar)							CL deg	H mm	SQ mm		
									2.0	3.0	4.0	5.0	6.0	7.0	10					
15°		KPB					KTB	1.9	3.18	3.90	4.50	5.03	5.52	5.96	7.12	22°	48	15		
		KPB					KTB	2.6	6.37	7.80	9.01	10.1	11.0	11.9	14.2	19°	54			
			KQB					KTB	3.2	9.55	11.7	13.5	15.1	16.5	17.9	21.4	25°	72	20	
			KQB					KTB	3.7	12.7	15.6	18.0	20.1	22.1	23.8	28.5	18°	92		
			KQB					KTB	4.2	15.9	19.5	22.5	25.2	27.6	29.8	35.6	15°	90		
				KRB					4.6	18.8	23.0	26.6	29.7	32.5	35.1	42.0	14°	125	25	
				KRB					5.3	25.3	31.0	35.8	40.0	43.8	47.4	56.6	14°	130		
				KRB		KSB			5.9	31.8	39.0	45.0	50.3	55.2	59.6	71.2	14°	137		
					KSB			8.4	63.7	78.0	90.1	101	110	119	142	14°	191	30		
25°		KPD					KTD	3.7	12.7	15.6	18.0	20.1	22.1	23.8	28.5	25°	65	20		
35°	KOH						KTH	1.2	1.31	1.60	1.85	2.07	2.26	2.44	2.92	40°	23	12		
			KPH					KTH	1.9	3.18	3.90	4.50	5.03	5.52	5.96	7.12	36°	37	15	
			KPH	KQH					KTH	2.6	6.37	7.80	9.01	10.1	11.0	11.9	14.2	30°	43	20
			KPH	KQH					KTH	2.9	8.00	9.80	11.3	12.7	13.9	15.0	17.9	28°	49	
			KPH	KQH					KTH	3.3	9.55	11.7	13.5	15.1	16.5	17.9	21.4	28°	52	
				KQH					KTH	3.7	12.7	15.6	18.0	20.1	22.1	23.8	28.5	26°	58	
				KQH					KTH	4.1	15.9	19.5	22.5	25.2	27.6	29.8	35.6	23°	64	
					KRH				KTH	4.5	18.8	23.0	26.6	29.7	32.5	35.1	42.0	22°	73	25
					KRH				KTH	5.3	25.3	31.0	35.8	40.0	43.8	47.4	56.6	24°	81	
					KRH					5.9	31.8	39.0	45.0	50.3	55.2	59.6	71.2	19°	89	
						KSH				7.5	51.4	63.0	72.7	81.3	89.1	96.2	115	23°	114	32
						KSH				8.4	63.7	78.0	90.1	101	110	119	142	22°	122	
40°			KQL				KTL	3.7	12.7	15.6	18.0	20.1	22.1	23.8	28.5	35°	60	25		
			KQL				KTL	4.1	15.9	19.5	22.5	25.2	27.6	29.8	35.6	33°	64			
			KQL					KTL	4.5	18.8	23.0	26.6	29.7	32.5	35.1	42.0	33°	72		
			KQL					KTL	5.0	22.0	27.0	31.2	34.9	38.2	41.2	49.3	29°	75		
			KQL					KTL	5.2	25.3	31.0	35.8	40.0	43.8	47.4	56.6	26°	77		
			KQL					KTL	5.7	28.6	35.0	40.4	45.2	49.5	53.5	63.9	28°	77		
			KQL					KTL	6.0	31.8	39.0	45.0	50.3	55.2	59.6	71.2	28°	87		
50°		KPN	KQN				KTN	1.5	1.63	2.00	2.31	2.58	2.83	3.06	3.65	50°	31	15		
		KPN	KQN				KTN	1.6	2.20	2.70	3.12	3.49	3.82	4.12	4.93	50°	31			
		KPN	KQN				KTN	1.9	3.18	3.90	4.50	5.03	5.52	5.96	7.12	60°	31			
		KPN	KQN				KTN	2.9	8.00	9.80	11.3	12.7	13.9	15.0	17.9	42°	41	20		
		KPN	KQN				KTN	3.7	12.7	15.6	18.0	20.1	22.1	23.8	28.5	45°	47			
		KPN	KQN				KTN	4.5	18.8	23.0	26.6	29.7	32.5	35.1	42.0	37°	55	25		
			KQN					KTN	6.0	31.8	39.0	45.0	50.3	55.2	59.6	71.2	40°	72	30	
			KQN					KTN	6.7	40.0	49.0	56.6	63.3	69.3	74.8	89.5	38°	72		
			KQN					KTN	7.5	51.4	63.0	72.7	81.3	89.1	96.2	115	37°	72		
			KQN					KTN	8.4	63.7	78.0	90.1	101	110	119	142	32°	72		

HOW TO MAKE UP THE NOZZLE CODE

Ex.: KPB 1390 B1

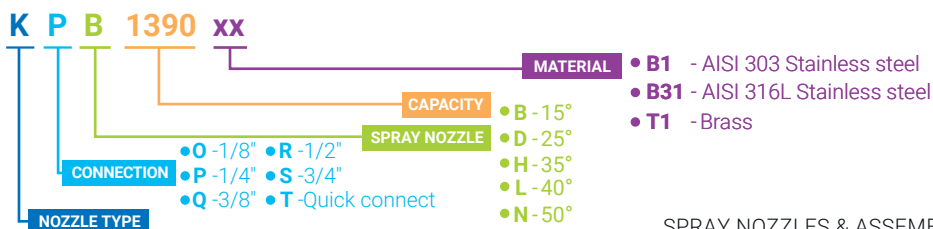

# SHOWER PIPE

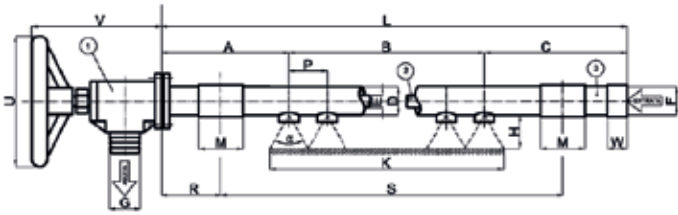

**LEGEND**

- A: first nozzle position
- B: nozzle span
- C: last nozzle position
- D: external diameter x pipe width
- E: shaft outer diameter
- F: inlet connection
- G: outlet connection
- H: height
- L: standard reference length
- M: support length
- N: nozzles number
- P: nozzle pitch
- R: support position
- S: sleeve span
- U: hand wheel diameter
- V: valve length
- W: nipple length
- α: spray angle
- (1): assy valve
- (2): assy shaft
- (3): assy pipe

The following table shows the minimum and the maximum values, for the pipes already produced by PNR Italia.

DIM.	MIN	MAX
D (mm)	Ø 50 x 1.5	Ø 73 x 3
L (mm)	600	7100
A (mm)	200	735
B (mm)	200	6000
C (mm)	200	1350
N	2	51
P (mm)	80	2950
F (inch)	1-1/2" F	2-1/2" F
G (mm)	Ø 48	Ø 60

The images show the functioning of the self-cleaning shower pipe, while rotating the wheel.

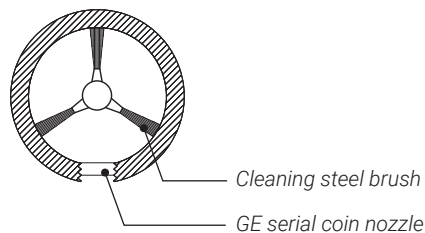

## SELF-CLEANING SHOWER PIPES

Self-cleaning shower pipes are used in the pulp and paper industry for washing and cleaning forming fabrics and felts. There are two kinds of pipes:

- Low pressure (2 ÷ 6 bar) fixed pipes with flat fan nozzles (PNR nozzle: GE)
- High pressure (25 ÷ 70 bar) oscillating pipes with straight jet nozzles (PNR nozzles: GEA)

Both fixed and oscillating pipes must have the following characteristics:

- presence of a cleaning system that cleans the nozzles with simultaneous discharge of impurities;
- easy and fast activation of the cleaning system, without interrupting the spray and without problems for the operators;
- usage of nozzles that allow to save water and that never get blocked, eventually after a long

Shower pipes that satisfy these three characteristics have a structure made of three main parts.

The **Assy Valve** must allow the passage or the stop of the discharge flux, through the opening or the closing of a lock, moved by a shaft, manually activated by a hand wheel. This movement is used to activate the Assy Shaft. The Assy Valve is connected to the Assy Pipe through a flanged connection, and to the discharge pipes through a specific connection (thread or hose fitting).

The **Assy Shaft** is made by a pipe with specific brushes mounted on it; thanks to the connection with the shaft of the Assy Valve, it moves radially and axially. In this way, the brushes can remove the impurities both from the nozzles and from the inner part of the Assy Pipe.

The nozzles are assembled on the **Assy Pipe**, which is connected to the main pipe. Nozzles can be installed with specific welding nipples or through plastic pipe clamps (PNR code: ZPH, see page 90).

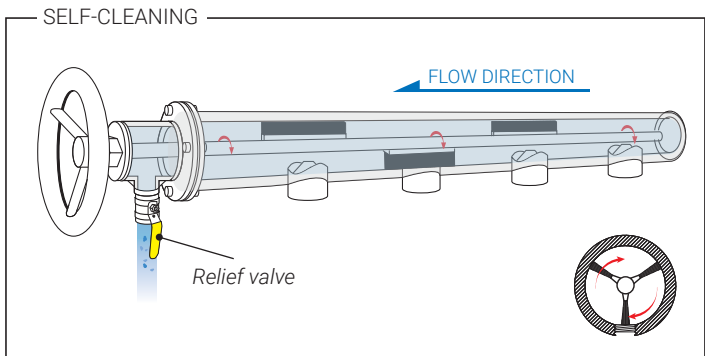
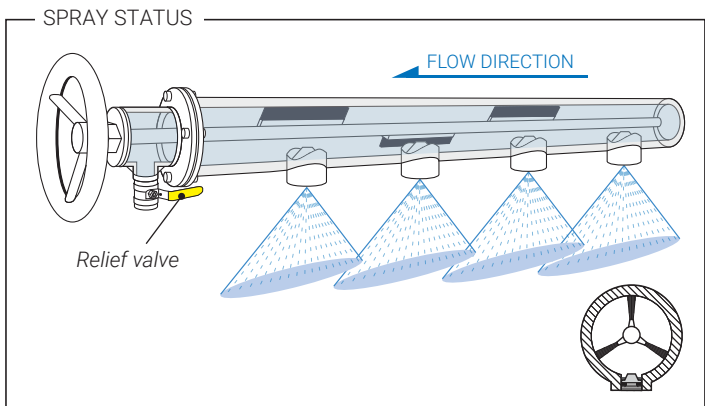

# ( FLAT FAN NOZZLES / DISC NOZZLES ) GE

## FLAT FAN NOZZLES / DISC NOZZLES

In GE series disc nozzles with thickness 1.2 mm the spray jet is close to the turbulence structure and this special design makes them very easy to clean. Within the delivery pipe these nozzles are assembled to a steel brush, that can be manually or automatically rotated, which takes off all the dirt washed out by water and then flushed out through a release valve positioned at the end of the pipe. Disc nozzles, with their special low profile design, can be easily removed for cleaning so they reduce maintenance times and costs and improve the plant efficiency.

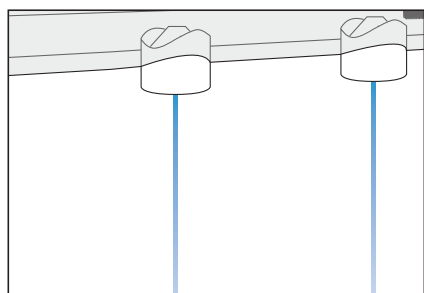

**TYPICAL APPLICATIONS**  
Washing or spraying in pulp and paper mills, mesh fabrics cleaning, water treatment systems, screen and filter (felt and wire) washing and more.

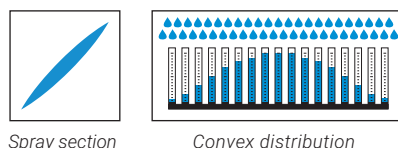

Spray angle	CODE	D1 mm	Capacity at different pressure values (l/min) (bar)					
			3.0	4.0	6.0	10	15	20
60°	GEQ 0900 xx	1.0	<b>0.90</b>	1.04	1.27	1.64	2.01	2.32
	GEQ 1170 xx	1.5	<b>1.70</b>	1.96	2.40	3.10	3.80	4.39
	GEQ 1234 xx	1.7	<b>2.34</b>	2.70	3.31	4.27	5.23	6.04
	GEQ 1310 xx	2.0	<b>3.10</b>	3.58	4.38	5.66	6.93	8.00
	GEQ 1490 xx	2.5	<b>4.90</b>	5.66	6.93	8.95	11.0	12.7
	GEQ 1780 xx	3.0	<b>7.80</b>	9.01	11.0	14.2	17.4	20.1
	GEQ 2124 xx	4.0	<b>12.4</b>	14.3	17.5	22.6	27.7	32.0
	GEQ 2194 xx	5.0	<b>19.4</b>	22.4	27.4	35.4	43.4	50.1
GEQ 2310 xx	7.0	<b>23.0</b>	26.6	32.5	42.0	51.4	59.4	
75°	GES 0900 xx	1.0	<b>0.90</b>	1.04	1.27	1.64	2.01	2.32
	GES 1170 xx	1.5	<b>1.70</b>	1.96	2.40	3.10	3.80	4.39
	GES 1234 xx	1.7	<b>2.34</b>	2.70	3.31	4.27	5.23	6.04
	GES 1310 xx	2.0	<b>3.10</b>	3.58	4.38	5.66	6.93	8.00
	GES 1490 xx	2.5	<b>4.90</b>	5.66	6.93	8.95	11.0	12.7
	GES 1780 xx	3.0	<b>7.80</b>	9.01	11.0	14.2	17.4	20.1
	GES 2124 xx	4.0	<b>12.4</b>	14.3	17.5	22.6	27.7	32.0
	GES 2194 xx	5.0	<b>19.4</b>	22.4	27.4	35.4	43.4	50.1
GES 2310 xx	7.0	<b>23.0</b>	26.6	32.5	42.0	51.4	59.4	

### FLAT FAN NOZZLES

HOW TO MAKE UP THE NOZZLE CODE Ex.: GES 1310 C7MV

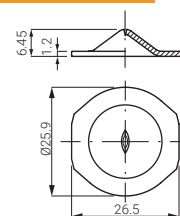

Flat fan nozzle - US  
GES 1310 C7SV

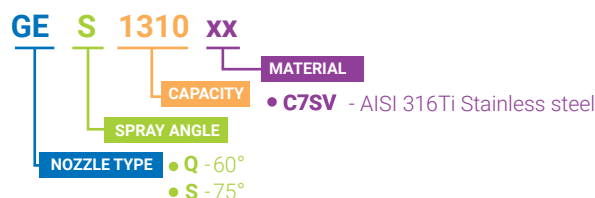

### GEA SERIAL STRAIGHT NOZZLES

D mm	Nozzle type		CODE	Capacity at different pressure values (l/min) (bar)					
	Stainless steel	Ruby insert		3.0	4.0	6.0	10	15	20
0.55	•	•	<b>0300</b>	<b>0.30</b>	0.35	0.42	0.55	0.67	0.77
0.38	•	•	<b>0380</b>	<b>0.12</b>	0.14	0.17	0.22	0.27	0.31
0.80	•	•	<b>0500</b>	<b>0.50</b>	0.58	0.71	0.91	1.12	1.29
0.63	•	•	<b>0630</b>	<b>0.34</b>	0.39	0.48	0.62	0.76	0.88
0.81	•	•	<b>0810</b>	<b>0.50</b>	0.58	0.71	0.91	1.12	1.29
1.00	•	•	<b>0900</b>	<b>0.90</b>	1.04	1.27	1.64	2.01	2.32
0.91	•	•	<b>0910</b>	<b>0.70</b>	0.81	0.99	1.28	1.57	1.81
1.02	•	•	<b>1010</b>	<b>0.88</b>	1.02	1.24	1.61	1.97	2.27
1.20	•	•	<b>1130</b>	<b>1.30</b>	1.50	1.84	2.37	2.91	3.36
1.30	•	•	<b>1170</b>	<b>1.70</b>	1.96	2.40	3.10	3.80	4.39
1.19	•	•	<b>1200</b>	<b>1.03</b>	1.19	1.46	1.88	2.30	2.66
2.00	•	•	<b>1310</b>	<b>3.10</b>	3.58	4.38	5.66	6.93	8.00

### STRAIGHT JET NOZZLES

HOW TO MAKE UP THE NOZZLE CODE Ex.: GEA 0900 C7S

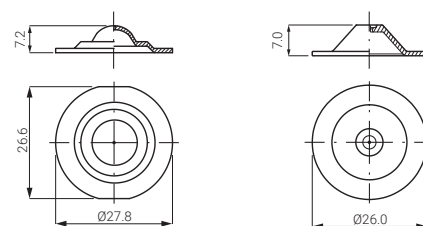

Metal  
GEA 0900 C7S

Ruby nozzle tip  
GEA 0900 F31

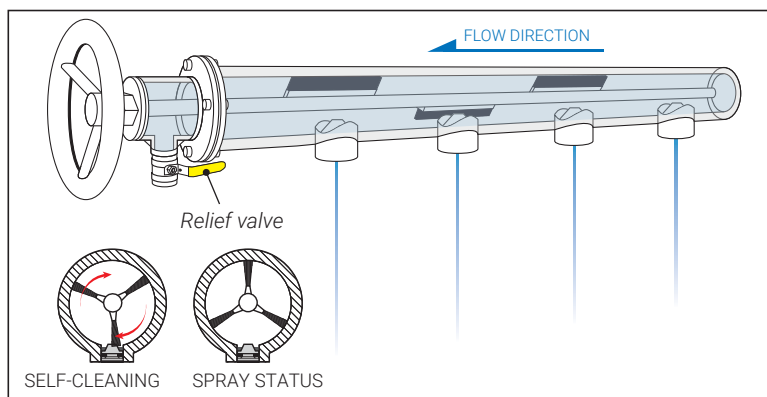
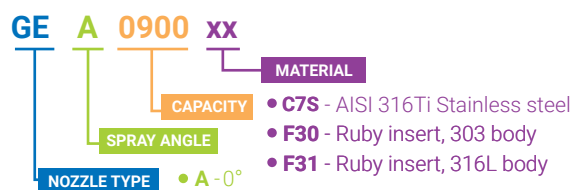

# GF ( FLAT FAN NOZZLES / SELF-CLEANING NOZZLES )

## GF SERIES SELF-CLEANING NOZZLES



The self-cleaning design of the GF series nozzles allow an easy maintenance of cleaning spray bars and shower headers. The nozzle body contains a mobile piston whose opening and closure is operated by the water pressure. For example, when nozzles wash mesh fabrics with an operating pressure of 3.0 bar, this pressure is higher than a spring force of 1.0 bar. Piston and nozzle body come close producing a flat fan spray. If the inlet pressure is reduced to 0.5 bar, lower than a spring force of 1.0 bar, piston and nozzle body separate opening to the maximum distance. Water pressure remains at 0.5 bar and removes any build up when back to normal condition. In a word, to clean these nozzles it's sufficient to reduce pressure to avoid the accumulation of dirt inside. GF self-cleaning nozzles are easy to install, align and clean ensuring relevant time and costs savings. The spring force is set depending on customer's plant working pressure.

### TYPICAL APPLICATIONS

Washing or spraying in pulp and paper mills, mesh fabrics cleaning, water treatment systems, and more.



Spray section

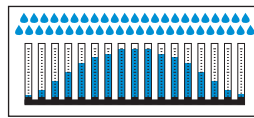

Convex distribution

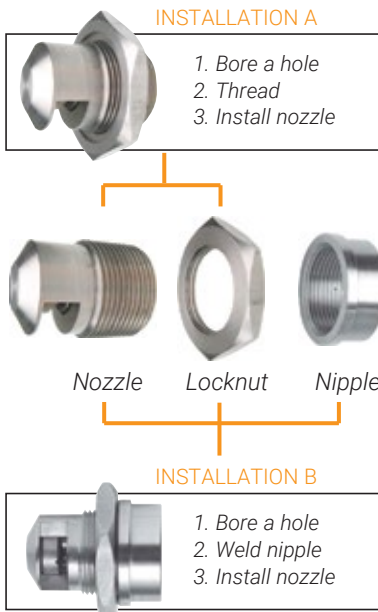
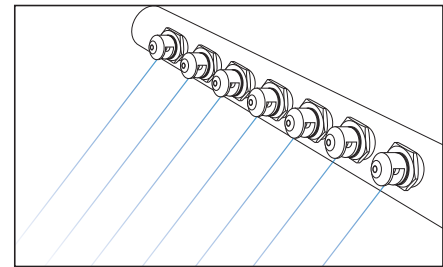

ANGLE	CODE	Capacity at different pressure values (l/min) (bar)								
		3.0	4.0	5.0	6.0	7.0	8.0	10	15	20
0°	GFA 1100 B31 xx	1.00	1.15	1.29	1.41	1.53	1.63	1.83	2.24	2.58
	GFA 1235 B31 xx	2.35	2.71	3.03	3.32	3.59	3.84	4.29	5.25	6.07
	GFA 1330 B31 xx	3.30	3.81	4.26	4.67	5.04	5.39	6.02	7.38	8.52
45°	GFM 1630 B31 xx	6.30	7.27	8.13	8.91	9.62	10.3	11.5	14.1	16.3
	GFM 1750 B31 xx	7.50	8.66	9.68	10.6	11.5	12.2	13.7	16.8	19.4
	GFM 1970 B31 xx	9.70	11.2	12.5	13.7	14.8	15.8	17.7	21.7	25.0
	GFM 2121 B31 xx	12.1	14.0	15.6	17.1	18.5	19.8	22.1	27.1	31.2
60°	GFM 2139 B31 xx	13.9	16.1	17.9	19.7	21.2	22.7	25.4	31.1	35.9
	GFQ 1630 B31 xx	6.30	7.27	8.13	8.91	9.62	10.3	11.5	14.1	16.3
	GFQ 1750 B31 xx	7.50	8.66	9.68	10.6	11.5	12.2	13.7	16.8	19.4
	GFQ 1970 B31 xx	9.70	11.2	12.5	13.7	14.8	15.8	17.7	21.7	25.0
80°	GFQ 2121 B31 xx	12.1	14.0	15.6	17.1	18.5	19.8	22.1	27.1	31.2
	GFQ 2139 B31 xx	13.9	16.1	17.9	19.7	21.2	22.7	25.4	31.1	35.9
	GFT 1630 B31 xx	6.30	7.27	8.13	8.91	9.62	10.3	11.5	14.1	16.3
	GFT 1750 B31 xx	7.50	8.66	9.68	10.6	11.5	12.2	13.7	16.8	19.4
	GFT 1970 B31 xx	9.70	11.2	12.5	13.7	14.8	15.8	17.7	21.7	25.0
	GFT 2121 B31 xx	12.1	14.0	15.6	17.1	18.5	19.8	22.1	27.1	31.2
	GFT 2139 B31 xx	13.9	16.1	17.9	19.7	21.2	22.7	25.4	31.1	35.9

Thread specification	M28 x 1.5	3/4" - 20 UNEF	1 1/8" - 18 UNEF	3/4" BSP
Nozzle	GFx xxxx B31SM	GFx xxxx B31SN	GFx xxxx B31SP	GFx xxxx B31SG
Nipple	XGF 2832 B31SM	XGF 2832 B31SN	XGF 2832 B31SP	XGF 2832 B31SG
Locknut	XGF 7010 B31SM	XGF 7010 B31SN	XGF 7010 B31SP	XGF 7010 B31SG

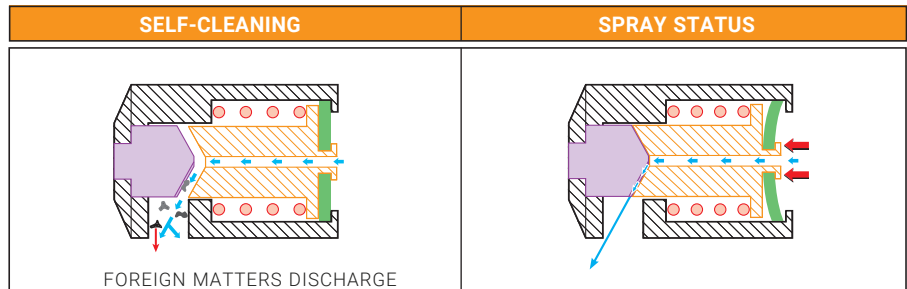

**HOW TO MAKE UP THE NOZZLE CODE**  
Ex.: GFA 1100 B31SM

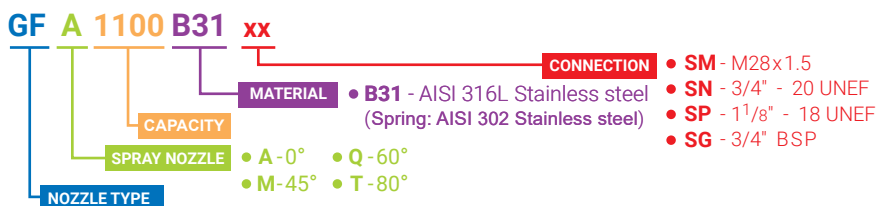



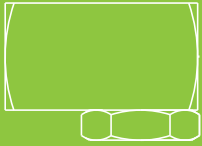

# HOLLOW CONE NOZZLES

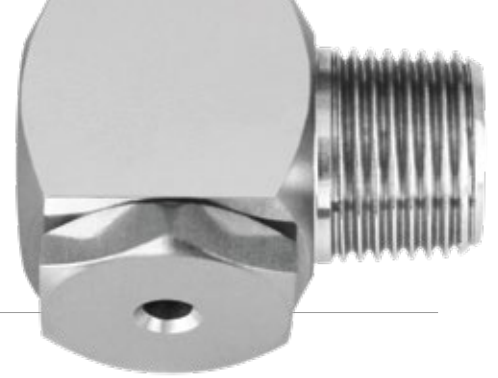

## MIST SPRAY

Hollow cone nozzles provide a finely atomized mist and a very uniform hollow cone spray pattern. They are ideal to capture suspended particles and offer higher performances than other nozzles with same operating pressure and capacity. These nozzles are widely used for their efficiency in cooling and cleaning of gases, dust control, absorption processes and air-humidification.

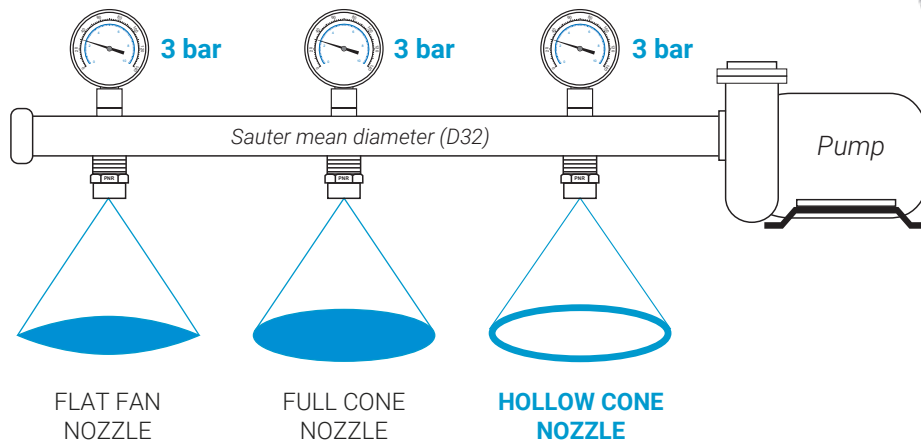

## POOR GAS SCRUB EFFICIENCY?

Hollow cone nozzles produce a ring-shaped spray pattern where all the liquid jet is concentrated on the outer edge of the ring. Users may fear that offset nozzles do not catch all suspended particles because air flows through directly from the centre. Hollow cone nozzles are the solution to this problem as their fine mist spray provides a better scrubbing effect.

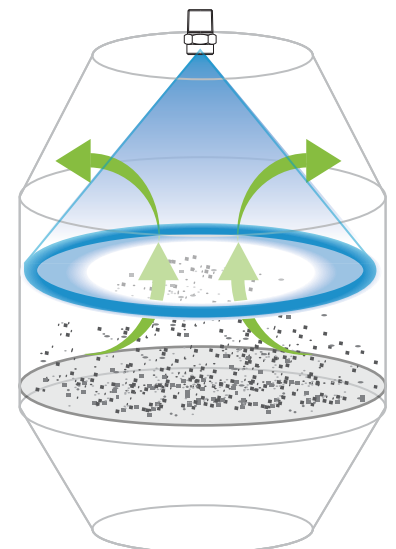

## ACCURATE OFFSET SETTINGS

The correct positioning of hollow cone nozzles is of vital importance. There are matrix and offset settings.

# PE / PF / PT ( HOLLOW CONE NOZZLES )

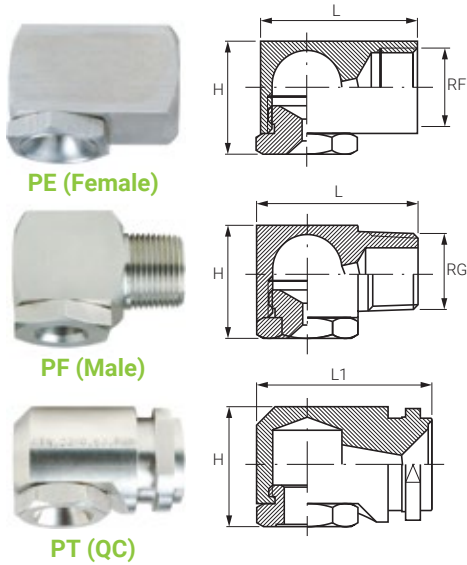

## STANDARD ANGLE SPRAY NOZZLES

PE/PF hollow cone nozzles generate a ring-shaped spray pattern with finely atomized droplets and work on the tangential flow principle. Inside these nozzles there is an axial groove that injects the liquid tangentially into the vortex chamber where the strong centrifugal force produces a high rotational velocity and generates a finely atomized liquid flow. As these nozzles have a large inside free passage and no swirl insert, they offer the maximum resistance to clogging. PE/PF nozzles are widely used in many production processes and their variety of spray angles and capacities make them suitable for all kinds of working environments.

### THREAD SPECIFICATION

- PE:** Female (BSP, NPT)
- PF:** Male (BSPT, NPT)
- PT:** Quick connection

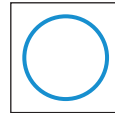

Spray section

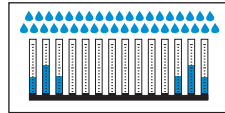

Concave distribution



## STANDARD ANGLE SPRAY NOZZLES

RF RG inch	PEN Female	PFN Male	PTN QC	CODE	DE mm	DU mm	Capacity at different pressure values								(l/min) (bar)		Dimensions mm		
							0.5	0.7	1.0	2.0	3.0	5.0	7.0	10	H	L	L1		
50°	3/8"		•	•	2180	5.9	7.9	7.35	8.69	10.4	14.7	18.0	23.2	27.5	32.9	24	34	35	
					2220	7.5	7.9	8.98	10.6	12.7	18.0	22.0	28.4	33.6	40.2				
					2390	8.7	9.5	15.9	18.8	22.5	31.8	39.0	50.3	59.6	71.2				
70°	1/8"		•		0390	0.79	1.2	0.16	0.19	0.23	0.32	0.39	0.50	0.60	0.71	19	24	26	
					0780	1.6	1.6	0.32	0.38	0.45	0.64	0.78	1.01	1.19	1.42				
					1160	2.0	2.0	0.65	0.77	0.92	1.31	1.60	2.07	2.44	2.92				
					1230	2.4	2.4	0.94	1.11	1.33	1.88	2.30	2.97	3.51	4.20				
					1390	3.2	3.2	1.59	1.88	2.25	3.18	3.90	5.03	5.96	7.12				
					1630	4.0	4.0	2.57	3.04	3.64	5.14	6.30	8.13	9.62	11.5				
	1/4"		•	•	•	0781	1.6	1.6	0.32	0.38	0.45	0.64	0.78	1.01	1.19	1.42	23	32	32
						1161	2.0	2.0	0.65	0.77	0.92	1.31	1.60	2.07	2.44	2.92			
						1231	2.4	2.4	0.94	1.11	1.33	1.88	2.30	2.97	3.51	4.20			
						1391	3.6	3.6	1.59	1.88	2.25	3.18	3.90	5.03	5.96	7.12			
						1631	4.0	4.0	2.57	3.04	3.64	5.14	6.30	8.13	9.62	11.5			
						1781	4.8	4.4	3.18	3.77	4.50	6.37	7.80	10.1	11.9	14.2			
	3/8"		•	•		1392	3.6	3.2	1.59	1.88	2.25	3.18	3.90	5.03	5.96	7.12	24	34	35
						1632	4.4	4.0	2.57	3.04	3.64	5.14	6.30	8.13	9.62	11.5			
						1782	5.2	4.4	3.18	3.77	4.50	6.37	7.80	10.1	11.9	14.2			
						2118	5.9	5.6	4.78	5.65	6.75	9.55	11.7	15.1	17.9	21.4			
						2157	7.1	6.4	6.41	7.58	9.06	12.8	15.7	20.3	24.0	28.7			
						2196	7.5	7.5	8.00	9.47	11.3	16.0	19.6	25.3	29.9	35.8			
	1/2"		•	•		2230	8.3	7.9	9.39	11.1	13.3	18.8	23.0	29.7	35.1	42.0	31	50	50
						2197	9.5	6.4	8.00	9.47	11.3	16.0	19.6	25.3	29.9	35.8			
						2231	9.5	7.5	9.39	11.1	13.3	18.8	23.0	29.7	35.1	42.0			
						2310	9.5	9.1	12.7	15.0	17.9	25.3	31.0	40.0	47.4	56.6			
						2391	9.5	11.1	15.9	18.8	22.5	31.8	39.0	50.3	59.6	71.2			
						2470	9.5	13.1	19.2	22.7	27.1	38.4	47.0	60.7	71.8	85.8			
3/4"		•	•		2311	12.7	7.9	12.7	15.0	17.9	25.3	31.0	40.0	47.4	56.6	39	55	58	
					2392	12.7	9.5	15.9	18.8	22.5	31.8	39.0	50.3	59.6	71.2				
					2471	12.7	11.1	19.2	22.7	27.1	38.4	47.0	60.7	71.8	85.8				
					2550	12.7	12.7	22.5	26.6	31.8	44.9	55.0	71.0	84.0	100				
					2630	12.7	14.3	25.7	30.4	36.4	51.4	63.0	81.3	96.2	115				
					2700	12.7	14.7	28.6	33.8	40.4	57.2	70.0	90.4	107	128				
					2780	12.7	15.9	31.8	37.7	45.0	63.7	78.0	101	119	142				
					2860	12.7	17.1	35.1	41.5	49.7	70.2	86.0	111	131	157				
					2940	12.7	18.3	38.4	45.4	54.3	76.8	94.0	121	144	172				

HOW TO MAKE UP THE NOZZLE CODE  
EX.: PES 1160 B1

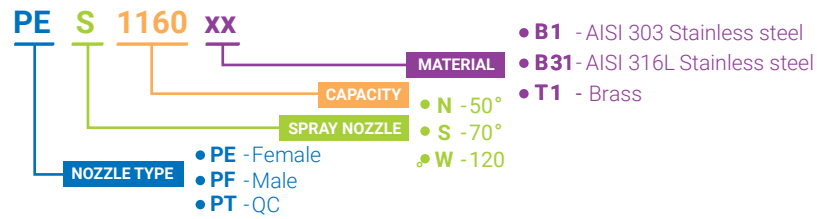

( HOLLOW CONE NOZZLES ) PE / PF / PT

WIDE ANGLE SPRAY NOZZLES

	RF	PEW	PFW	PTW	CODE	DE	DU	Capacity at different pressure values								Dimensions		
	RG	Female	Male	QC		mm	mm	(l/min) (bar)								mm		
	inch					0.5	0.7	1.0	2.0	3.0	5.0	7.0	10	H	L	L1		
120°	1/8"	•	•		<b>0390</b>	0.79	1.2	0.16	0.19	0.23	0.32	0.39	0.50	0.60	0.71	19	24	26
		•	•		<b>0780</b>	1.6	1.6	0.32	0.38	0.45	0.64	0.78	1.01	1.19	1.42			
		•	•		<b>1200</b>	2.0	2.8	0.82	0.97	1.15	1.63	2.00	2.58	3.06	3.65			
		•	•		<b>1230</b>	2.4	2.8	0.94	1.11	1.33	1.88	2.30	2.97	3.51	4.20			
		•	•		<b>1270</b>	2.4	3.2	1.10	1.30	1.56	2.20	2.70	3.49	4.12	4.93			
		•	•		<b>1320</b>	2.0	4.4	1.31	1.55	1.85	2.61	3.20	4.13	4.89	5.84			
	1/4"	•	•	•	<b>1390</b>	3.2	3.2	1.59	1.88	2.25	3.18	3.90	5.03	5.96	7.12	23	32	32
		•	•	•	<b>1510</b>	3.2	4.4	2.08	2.46	2.94	4.16	5.10	6.58	7.79	9.31			
		•	•	•	<b>1700</b>	4.0	4.4	2.86	3.38	4.04	5.72	7.00	9.04	10.7	12.8			
		•	•	•	<b>0781</b>	1.6	1.6	0.32	0.38	0.45	0.64	0.78	1.01	1.19	1.42			
		•	•	•	<b>1130</b>	1.6	3.2	0.53	0.63	0.75	1.06	1.30	1.68	1.99	2.37			
		•	•	•	<b>1160</b>	1.6	4.4	0.65	0.77	0.92	1.31	1.60	2.07	2.44	2.92			
3/8"	1/2"	•	•	•	<b>1190</b>	1.6	5.6	0.78	0.92	1.10	1.55	1.90	2.45	2.90	3.47	24	34	35
		•	•	•	<b>1271</b>	2.0	3.2	1.10	1.30	1.56	2.20	2.70	3.49	4.12	4.93			
		•	•	•	<b>1321</b>	2.0	4.4	1.31	1.55	1.85	2.61	3.20	4.13	4.89	5.84			
		•	•	•	<b>1391</b>	3.6	3.2	1.59	1.88	2.25	3.18	3.90	5.03	5.96	7.12			
		•	•	•	<b>1511</b>	3.6	4.4	2.08	2.46	2.94	4.16	5.10	6.58	7.79	9.31			
		•	•	•	<b>1600</b>	3.6	5.6	2.45	2.90	3.46	4.90	6.00	7.75	9.17	11.0			
	3/4"	•	•	•	<b>1701</b>	4.0	4.4	2.86	3.38	4.04	5.72	7.00	9.04	10.7	12.8	24	34	35
		•	•	•	<b>1780</b>	4.8	4.4	3.18	3.77	4.50	6.37	7.80	10.1	11.9	14.2			
		•	•	•	<b>1860</b>	4.0	5.6	3.51	4.15	4.97	7.02	8.60	11.1	13.1	15.7			
		•	•	•	<b>1940</b>	4.8	5.6	3.84	4.54	5.43	7.68	9.40	12.1	14.4	17.2			
		•	•	•	<b>2102</b>	4.4	7.5	4.16	4.93	5.89	8.33	10.2	13.2	15.6	18.6			
		•	•	•	<b>2110</b>	5.2	6.0	4.49	5.31	6.35	8.98	11.0	14.2	16.8	20.1			
1/2"	•	•	•	<b>2118</b>	6.0	5.6	4.78	5.65	6.75	9.55	11.7	15.1	17.9	21.4	24	34	35	
	•	•	•	<b>2133</b>	6.0	6.0	5.43	6.42	7.68	10.9	13.3	17.2	20.3	24.3				
	•	•	•	<b>2157</b>	7.1	6.0	6.41	7.58	9.06	12.8	15.7	20.3	24.0	28.7				
	•	•	•	<b>2172</b>	6.0	7.9	7.02	8.31	9.93	14.0	17.2	22.2	26.3	31.4				
	•	•	•	<b>2196</b>	7.5	7.5	8.00	9.47	11.3	16.0	19.6	25.3	29.9	35.8				
	•	•	•	<b>2220</b>	7.5	7.9	8.98	10.6	12.7	18.0	22.0	28.4	33.6	40.2				
1/2"		•	•	<b>2391</b>	9.5	11.1	15.9	18.8	22.5	31.8	39.0	50.3	59.6	71.2	31	50	50	
3/4"		•		<b>2630</b>	12.7	14.3	25.7	30.4	36.4	51.4	63.0	81.3	96.2	115	39	55	58	

# PA / PB ( HOLLOW CONE NOZZLES / LARGE CAPACITY )

## TANGENTIAL NOZZLES



PA

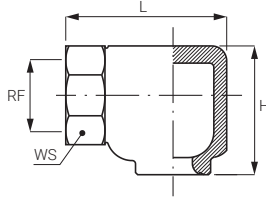

PA/PB tangential nozzles generate a hollow cone spray pattern of finely atomized droplets and work on the tangential flow principle. They are designed with a tangential method of atomization. Inside these nozzles there is an axial groove that injects the liquid tangentially into the vortex chamber where the strong centrifugal force produces a high rotational velocity and generates a finely atomized liquid flow. As these nozzles have a large free passage inside and no swirl insert, they offer the maximum resistance to clogging. PA/PB nozzles are widely used in exhaust scrubbers and are suitable to spray flows with particles.



PB

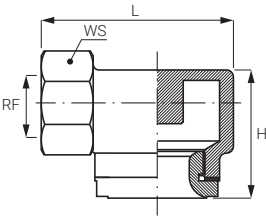

THREAD SPECS: BSP, NPT (on request)  
 TYPICAL APPLICATIONS  
*Washing:* exhaust scrubbers, desulfuration, denitrification  
*Cooling:* cooling of high temperature gas, product cooling

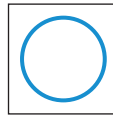

Spray section

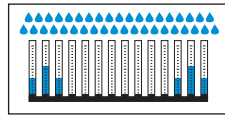

Concave distribution

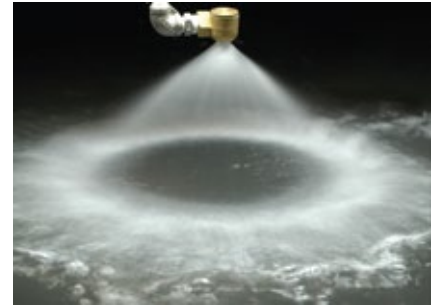

70° 90° 130°	CODE	RF inch	DE mm	DU mm	Capacity at different pressure values									Dimensions mm			
					0.3	0.5	0.7	1.0	2.0	3.0	5.0	7.0	10	H	L	WS	
70° 90°	PAS 1170 xx	3/8"	3.5	2.0	0.54	0.69	0.82	0.98	1.39	1.70	2.19	2.60	3.10	27	37	22	
	PAU 1390 xx	3/8"	4.0	3.8	1.23	1.59	1.88	2.25	3.18	3.90	5.03	5.96	7.12				
	PAU 1670 xx	1/2"	5.6	5.2	2.12	2.74	3.24	3.87	5.47	6.70	8.65	10.2	12.2	38	46	27	
	PAU 1850 xx		5.7	6.0	2.69	3.47	4.11	4.91	6.94	8.50	11.0	13.0	15.5				
	PAU 2115 xx		6.6	6.9	3.64	4.69	5.56	6.64	9.39	11.5	14.8	17.6	21.0				
	PAU 2220 xx	3/4"	8.5	9.0	6.96	8.98	10.6	12.7	18.0	22.0	28.4	33.6	40.2	48	60	36	
	PAU 2320 xx		9.5	11.5	10.1	13.1	15.5	18.5	26.1	32.0	41.3	48.9	58.4				
	PAU 2420 xx		9.6	14.0	13.3	17.1	20.3	24.2	34.3	42.0	54.2	64.2	76.7				
	PAU 2730 xx	1"	20x10	13.7	23.1	29.8	35.3	42.1	59.6	73.0	94.2	112	133	60	75	46	
	PAU 2970 xx			16.5	30.7	39.6	46.9	56.0	79.2	97.0	125	148	177				
	PAU 3147 xx	1 1/2"	32x16	19.5	46.5	60.0	71.0	84.9	120	147	190	225	268	90	93	60	
	PAU 3194 xx			22.0	61.3	79.2	93.7	112	158	194	250	296	354				
PAU 3244 xx	2"	35x20	26.5	77.2	99.6	118	141	199	244	315	373	445	127	117	80		
PAU 3294 xx			28.5	93.0	120	142	170	240	294	380	449	537					
PAU 3364 xx	2 1/2"	25x40	29.5	115	149	176	210	297	364	470	556	665	156	140	100		
PAU 3490 xx			36.5	155	200	237	283	400	490	633	748	895					
PAU 3605 xx			45.0	191	247	292	349	494	605	781	924	1105					
130°	PBY 1390 xx	3/8"	3.0	4.5	1.23	1.59	1.88	2.25	3.18	3.90	5.03	5.96	7.12	27	37	22	
	PBY 1850 xx		4.4	7.5	2.69	3.47	4.11	4.91	6.94	8.50	11.0	13.0	15.5				
	PBY 1980 xx	1/2"	4.0	12.0	3.10	4.00	4.73	5.66	8.00	9.80	12.7	15.0	17.9	35	46	27	
	PBY 2128 xx		4.7	12.0	4.05	5.23	6.18	7.39	10.5	12.8	16.5	19.6	23.4				
	PBY 2208 xx		6.5	12.0	6.58	8.49	10.0	12.0	17.0	20.8	26.9	31.8	38.0				
	PBY 2220 xx	3/4"	6.1	15.0	6.96	8.98	10.6	12.7	18.0	22.0	28.4	33.6	40.2	50	60	36	
	PBY 2320 xx			6.5	19.0	10.1	13.1	15.5	18.5	26.1	32.0	41.3	48.9				58.4
	PBY 2420 xx			8.0	19.0	13.3	17.1	20.3	24.2	34.3	42.0	54.2	64.2				76.7
	PBY 2730 xx	1"	13.4	26.0	23.1	29.8	35.3	42.1	59.6	73.0	94.2	112	133	60	93	47	
	PBY 2970 xx			14.0	26.0	30.7	39.6	46.9	56.0	79.2	97.0	125	148				177
	PBY 3147 xx	1 1/2"	15.0	37.0	46.5	60.0	71.0	84.9	120	147	190	225	268	75	111	60	
	PBY 3194 xx			19.5	37.0	61.3	79.2	93.7	112	158	194	250	296				354
	PBY 3244 xx	2"	22.0	45.0	77.2	99.6	118	141	199	244	315	373	445	91	140	75	
	PBY 3294 xx			27.1	45.0	93.0	120	142	170	240	294	380	449				537
	PBY 3364 xx	2 1/2"	25.5	64.0	115	149	176	210	297	364	470	556	665	128	193	90	
PBY 3490 xx			33.0	64.0	155	200	237	283	400	490	633	748	895				
PBY 3605 xx			38.0	64.0	191	247	292	349	494	605	781	924	1105				
PBY 3665 xx		43.0	64.0	210	271	321	384	543	665	859	1016	1214					

### THREAD SIZE AND MATERIALS

The table on the right side shows thread size and materials.

MATERIAL	3/8"	1/2"	3/4"	1"	1 1/2"	2"	2 1/2"
B31 - AISI 316L				•	•	•	•
T1 - Brass	•	•	•	•			

### HOW TO MAKE UP THE NOZZLE CODE

Ex.: PAS 1170 B31

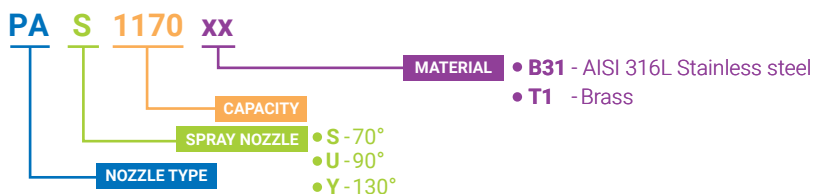

# ( HOLLOW CONE NOZZLES ) PN / PO / PS

## MOULDED PLASTIC NOZZLES

PN/PO series hollow cone nozzles made by plastic moulding, offer a high chemical resistance and low prices. They are tangential nozzles and produce a hollow cone spray of atomized droplets. As they have a large free passage and no swirling vane inside their body, they are highly clog-resistant. PN/PO nozzles are efficient, cost-effective and widely used in many processing lines. Moreover, they can be easily assembled in large quantity onto pipe manifolds.



### THREAD SPECIFICATION

**PO:** Male BSPT, NPT  
**PN:** Female BSP, NPT  
**PS:** Quick-fit  
 Max operation temperature: 100 °C  
 Max operation pressure: 10 bar

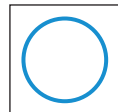

Spray section

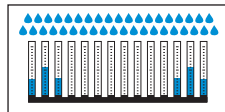

Concave distribution

CODE	Conn.	L	L1	H	H1	CH1	CH2	D
		mm	mm	mm	mm			
PN	3/8" F	47.5	32.0	39.0	28.0	28	22	---
	1/2" F	51.5	36.0	39.0	28.0	28	24	---
PO	3/8" M	53.5	38.0	39.0	28.0	28	---	---
PS	Quick-fit	71.5	56.0	39.0	28.0	28	---	24.0

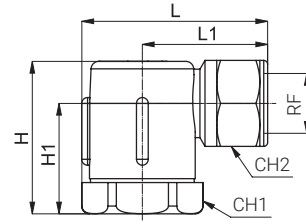

PN - Female

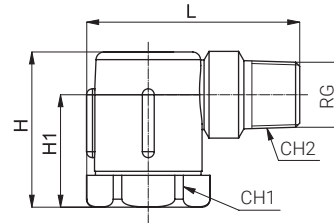

PO - Male

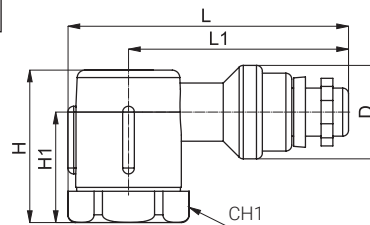

PS - Quick connection

PNx Female	POx Male	PSx Quick connect.	CODE	Thread	Capacity at different pressure values (l/min) (bar)							
					0.5	0.7	1.0	2.0	3.0	5.0	7.0	10
•	•	•	1170	3/8" Quick-fit	0.69	0.82	0.98	1.39	1.70	2.19	2.60	3.10
•	•	•	1390		1.59	1.88	2.25	3.18	3.90	5.03	5.96	7.12
•	•	•	1460		1.88	2.22	2.66	3.76	4.60	5.94	7.03	8.40
•	•	•	1570		2.33	2.75	3.29	4.65	5.70	7.36	8.71	10.4
•	•	•	1670		2.74	3.24	3.87	5.47	6.70	8.65	10.2	12.2
•	•	•	1850		3.47	4.11	4.91	6.94	8.50	11.0	13.0	15.5
•	•	•	1980		4.00	4.73	5.66	8.00	9.80	12.7	15.0	17.9
•	•	•	2115		4.69	5.56	6.64	9.39	11.5	14.8	17.6	21.0
•	•	•	2128		5.23	6.18	7.39	10.5	12.8	16.5	19.6	23.4
•	•	•	2208		8.49	10.0	12.0	17.0	20.8	26.9	31.8	38.0
•	•	•	2220	8.98	10.6	12.7	18.0	22.0	28.4	33.6	40.2	
•	•	•	2319	13.1	15.5	18.5	26.1	32.0	41.3	48.9	58.4	
•			2129	1/2"	5.23	6.18	7.39	10.5	12.8	16.5	19.6	23.4
•			2209		8.49	10.0	12.0	17.0	20.8	26.9	31.8	38.0
•			2221		8.98	10.6	12.7	18.0	22.0	28.4	33.6	40.2
•			2320		13.1	15.5	18.5	26.1	32.0	41.3	48.9	58.4
•			2420		17.1	20.3	24.2	34.3	42.0	54.2	64.2	76.6

### PO MALE THREAD NOZZLES

ZPB fastening clamps in plastic usually connect to nozzles with 3/8" female threads. They are flexible, durable and low cost. Please see more on page 88.



PN (Female) + ZPB Plastic pipe clamp

### TYPICAL APPLICATIONS

**Washing:** exhaust scrubbers, parts cleaning, pre-treatment in coating process, dust and foam control, filter spraying  
**Cooling:** wire cooling, plastic pipe cooling  
**Other applications:** humidification systems, etc.

### HOW TO MAKE UP THE NOZZLE CODE

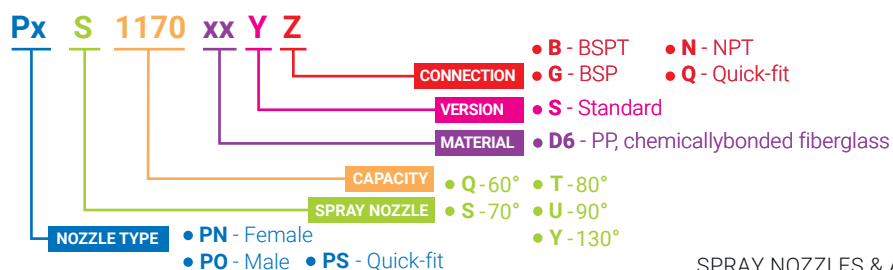



# PR (HOLLOW CONE NOZZLES)

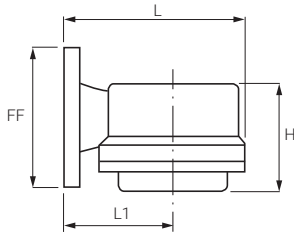

## TANGENTIAL NOZZLES / LARGE FLOW RATES

PR nozzles produce a hollow cone spray pattern based on the tangential jet principle generating atomized flows with large flow rates. They have a vaneless and large free inside passage and offer a considerable resistance to clogging and high performances.

FLANGE  
DIN2633-ND16, JIS

TYPICAL APPLICATIONS  
Desulfurization  
Denitrification  
Exhaust scrubbers  
Coke quenching towers

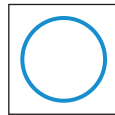

Spray section

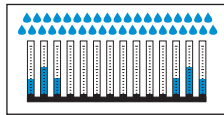

Concave distribution

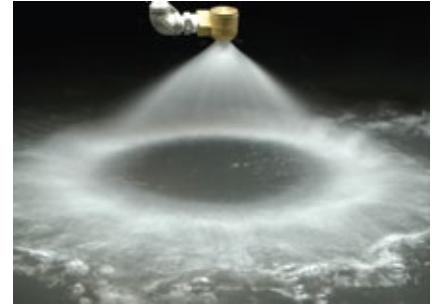

130°	CODE	DN inch	DE mm	DU mm	Capacity (l/min) at different pressure values (bar)					Dimensions mm			
					0.5	1.0	2.0	3.0	5.0	FF	H	L	L1
130°	PRY 3612 xx	3"	31.0	90	250	353	500	612	790	200	157	250	150
	PRY 3685 xx		34.0	90	280	395	559	685	884				
	PRY 3771 xx		36.5	90	315	445	630	771	995				
	PRY 3869 xx		39.5	90	355	502	710	869	1122				
	PRY 3979 xx		40.0	90	400	565	799	979	1264				
	PRY 4110 xx		43.0	90	449	635	898	1100	1420				
	PRY 4122 xx		50.0	90	498	704	996	1220	1575				
	PRY 4153 xx		57.0	90	625	883	1249	1530	1975				
	PRY 4195 xx	4"	60.0	145	796	1126	1592	1950	2517	220	242	355	200
	PRY 4244 xx		70.0	145	996	1409	1992	2440	3150				
	PRY 4306 xx		79.0	145	1249	1767	2498	3060	3950				
	PRY 4385 xx		87.0	145	1572	2223	3144	3850	4970				

HOW TO MAKE UP THE NOZZLE CODE

EX.: PRY 3612 B31

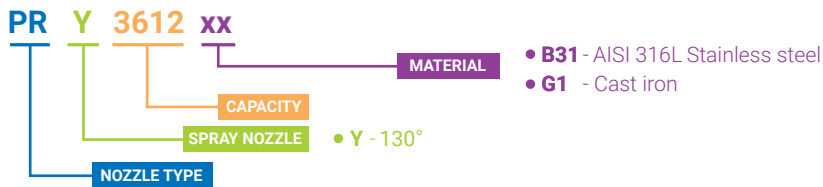

( HOLLOW CONE NOZZLES / IN LINE SPRAY )

RA

IN LINE SPRAY / INSIDE VANE

RA nozzles are tangential hollow cone nozzles that produce a finely atomized spray in line with the inlet supply pipe. In their body there is a carefully machined swirl vane with two spiral grooves which produce a wide range of capacities, starting from very low values. The strong centrifugal force inside the vortex chamber creates a high speed rotation of the liquid flow producing an atomized mist. For small capacity RA nozzles we suggest to place a suitable filter before their inlet orifice to avoid clogging.

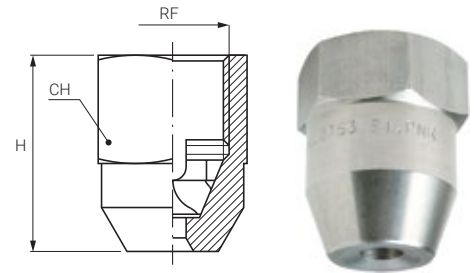

THREAD SPECIFICATION: BSP, NPT

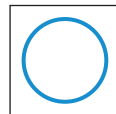

Spray section

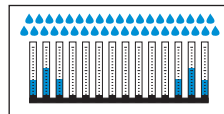

Concave distribution

°	CODE	RF inch	D mm	D1 mm	Capacity at different pressure values								Dimensions mm	
					0.5	0.7	1.0	2.0	3.0	5.0	7.0	10	H	CH
80°	RAT 0200 xx	1/8"	1.0	0.5	0.08	0.10	0.12	0.16	0.20	0.26	0.31	0.37	18	17
	RAT 0390 xx		1.7	0.5	0.16	0.19	0.23	0.32	0.39	0.50	0.60	0.71		
60°	RAQ 0490 xx	3/8"	1.1	0.6	0.20	0.24	0.28	0.40	0.49	0.63	0.75	0.89	29	22
	RAQ 0770 xx		1.6	0.6	0.31	0.37	0.44	0.63	0.77	0.99	1.18	1.41		
	RAQ 1122 xx		2.0	0.6	0.50	0.59	0.70	1.00	1.22	1.58	1.86	2.23		
90°	RAU 1208 xx	3/8"	3.0	1.0	0.85	1.00	1.20	1.70	2.08	2.69	3.18	3.80	29	22
	RAU 1306 xx		4.0	1.6	1.25	1.48	1.77	2.50	3.06	3.95	4.67	5.59		
	RAU 1490 xx		4.2	1.6	2.00	2.37	2.83	4.00	4.90	6.33	7.48	8.95		
	RAU 1612 xx		4.7	1.6	2.50	2.96	3.53	5.00	6.12	7.90	9.35	11.2		
	RAU 1772 xx		5.5	1.6	3.15	3.73	4.46	6.30	7.72	9.97	11.8	14.1		
	RAU 2104 xx	6.3	1.6	4.25	5.02	6.00	8.49	10.4	13.4	15.9	19.0			
	RAU 1491 xx	1/2"	5.0	1.8	2.00	2.37	2.83	4.00	4.90	6.33	7.48	8.95	36	27
	RAU 1551 xx		5.5	1.8	2.25	2.66	3.18	4.50	5.51	7.11	8.42	10.1		
	RAU 1686 xx		6.0	1.8	2.80	3.31	3.96	5.60	6.86	8.86	10.5	12.5		
	RAU 1980 xx		6.3	2.0	4.00	4.73	5.66	8.00	9.80	12.7	15.0	17.9		
	RAU 2137 xx		6.7	2.0	5.59	6.62	7.91	11.2	13.7	17.7	20.9	25.0		
RAU 2153 xx	7.5		2.0	6.25	7.39	8.83	12.5	15.3	19.8	23.4	27.9			
RAU 2196 xx	9.0	2.0	8.00	9.47	11.3	16.0	19.6	25.3	29.9	35.8				

TYPICAL APPLICATIONS

Cooling: gas, products, pipes cooling

Washing: exhaust scrubbers, parts washing

Other applications: dust control, humidification and air refreshing systems

HOW TO MAKE UP THE NOZZLE CODE  
EX.: RAT 0200 B31

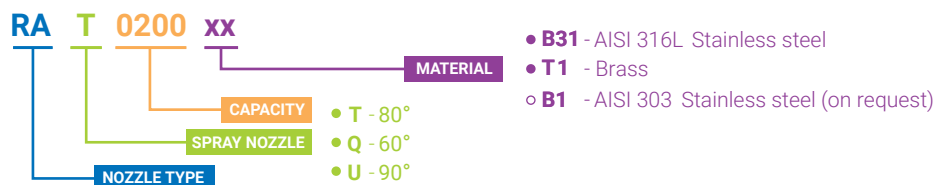

# RB (HOLLOW CONE NOZZLES / VANELESS)

## IN LINE SPRAY / VANELESS

These nozzles, designed with no inside whirling vane and a wide unobstructed passage, produce a hollow cone spray pattern, and are highly resistant to clogging. The liquid flow enters at high speed through the top eccentric orifice into the nozzle swirl chamber where the strong centrifugal force generates finely atomized droplets. These nozzles, the ideal choice for dust control applications, are particularly suitable for coal dust suppression and for this reason they are called "miner's nozzles".

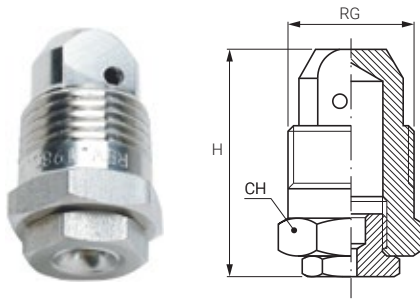

THREAD SPECIFICATION: BSPT, NPT

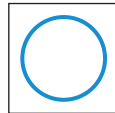

Spray section

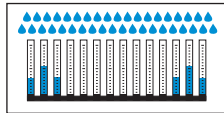

Concave distribution



°	CODE	RG inch	D mm	D1 mm	Capacity at different pressure values (l/min) (bar)								Dimensions mm	
					0.5	0.7	1.0	2.0	3.0	5.0	7.0	10	H	CH
60°	<b>RBQ 1160 xx</b>	3/8"	2.0	2.0	0.65	0.77	0.92	1.31	1.60	2.07	2.44	2.92	31	17
	<b>RBQ 1230 xx</b>		2.4	2.4	0.94	1.11	1.33	1.88	2.30	2.97	3.51	4.20		
	<b>RBQ 1390 xx</b>		3.2	2.3	1.59	1.88	2.25	3.18	3.90	5.03	5.96	7.12		
	<b>RBQ 1630 xx</b>		3.9	3.8	2.57	3.04	3.64	5.14	6.30	8.13	9.62	11.5		
	<b>RBQ 2110 xx</b>		4.4	*4.0	4.49	5.31	6.35	8.98	11.0	14.2	16.8	20.1		
70°	<b>RBS 1391 xx</b>	1/2"	3.5	3.0	1.59	1.88	2.25	3.18	3.90	5.03	5.96	7.12	37	22
	<b>RBS 1631 xx</b>		4.0	4.0	2.57	3.04	3.64	5.14	6.30	8.13	9.62	11.5		
	<b>RBS 1781 xx</b>		4.5	2.9	3.18	3.77	4.50	6.37	7.80	10.1	11.9	14.2		
	<b>RBS 2117 xx</b>		5.1	*3.4	4.82	5.70	6.81	9.63	11.8	15.2	18.0	21.5		
	<b>RBS 2157 xx</b>		7.0	*3.6	6.45	7.63	9.12	12.9	15.8	20.4	24.1	28.8		
	<b>RBS 2196 xx</b>	7.3	*4.8	7.96	9.42	11.3	15.9	19.5	25.2	29.8	35.6			
	<b>RBS 1782 xx</b>	3/4"	4.7	4.5	3.18	3.77	4.50	6.37	7.80	10.1	11.9	14.2	43	32
	<b>RBS 2118 xx</b>		5.9	4.8	4.82	5.70	6.81	9.63	11.8	15.2	18.0	21.5		
	<b>RBS 2197 xx</b>		7.0	6.5	7.96	9.42	11.3	15.9	19.5	25.2	29.8	35.6		
	<b>RBS 2390 xx</b>		9.3	*6.0	15.9	18.8	22.5	31.8	39.0	50.3	59.6	71.2		
<b>RBS 2390 xx</b>	9.3		*6.0	15.9	18.8	22.5	31.8	39.0	50.3	59.6	71.2			
80°	<b>RBT 2310 xx</b>	1 1/2"	10.0	*7.0	12.7	15.0	17.9	25.3	31.0	40.0	47.4	56.6	69	50
	<b>RBT 2550 xx</b>		12.9	*8.5	22.5	26.6	31.8	44.9	55.0	71.0	84.0	100		
	<b>RBT 2630 xx</b>		15.0	*8.5	25.7	30.4	36.4	51.4	63.0	81.3	96.2	115		
	<b>RBT 2700 xx</b>		14.6	*9.0	28.6	33.8	40.4	57.2	70.0	90.4	107	128		
	<b>RBT 2940 xx</b>		19.8	*10.0	38.4	45.4	54.3	76.8	94.0	121	144	172		

\* Double inlet orifice

### TYPICAL APPLICATIONS

Cooling: gas cooling, product cooling, pipe cooling

Washing: exhaust scrubbers, product cleaning

Other applications: dust control, humidification systems, sterilization

### HOW TO MAKE UP THE NOZZLE CODE

EX.: RBQ 1160 B1

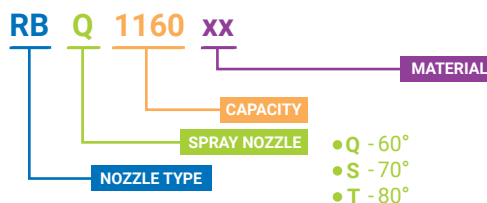

- B1 - AISI 303 Stainless steel
- T1 - Brass
- B31 - AISI 316L Stainless steel (on request)

( HOLLOW CONE NOZZLES ) **RC**

IN LINE SPRAY

RC type deflected nozzles produce a ring-shaped hollow cone spray pattern, in line with the nozzle inlet supply pipe. The water flow hits the deflection cap fixed onto the nozzle outlet orifice producing small droplets, very wide spray angles and uniform distribution. The deflection cap determines the various deflection angles. This nozzles are highly efficient and clog resistant.

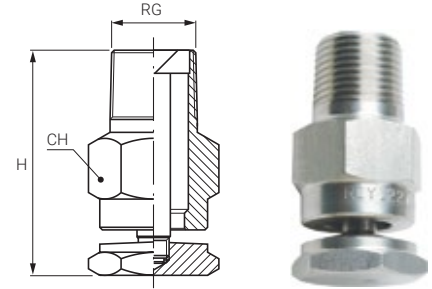

THREAD SPECIFICATION: BSPT, NPT

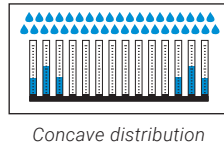
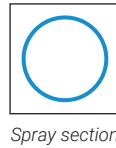

Spray Angle	RG inch		CODE	Capacity at different pressure values (l/min) (bar)								Dimensions mm	
	1/4"	3/8"		0.5	0.7	1.0	2.0	3.0	5.0	7.0	10	H	CH
150°	•		RCY 1780 xx	3.18	3.77	4.50	6.37	7.80	10.1	11.9	14.2	33	17
			RCY 2117 xx	4.82	5.70	6.81	9.63	11.8	15.2	18.0	21.5		
			RCY 2157 xx	6.41	7.58	9.06	12.8	15.7	20.3	24.0	28.7		
			RCY 2196 xx	7.96	9.42	11.3	15.9	19.5	25.2	29.8	35.6		
	•		RCY 2230 xx	9.39	11.1	13.3	18.8	23.0	29.7	35.1	42.0	44	22
			RCY 2270 xx	11.0	13.0	15.6	22.0	27.0	34.9	41.2	49.3		
			RCY 2310 xx	12.7	15.0	17.9	25.3	31.0	40.0	47.4	56.6		
180°	•		RCZ 1780 xx	3.18	3.77	4.50	6.37	7.80	10.1	11.9	14.2	33	17
			RCZ 2117 xx	4.82	5.70	6.81	9.63	11.8	15.2	18.0	21.5		
			RCZ 2157 xx	6.41	7.58	9.06	12.8	15.7	20.3	24.0	28.7		
			RCZ 2196 xx	7.96	9.42	11.3	15.9	19.5	25.2	29.8	35.6		
	•		RCZ 2230 xx	9.39	11.1	13.3	18.8	23.0	29.7	35.1	42.0	44	22
			RCZ 2270 xx	11.0	13.0	15.6	22.0	27.0	34.9	41.2	49.3		
			RCZ 2310 xx	12.7	15.0	17.9	25.3	31.0	40.0	47.4	56.6		
•		RCZ 2350 xx	14.3	16.9	20.2	28.6	35.0	45.2	53.5	63.9			
		RCZ 2390 xx	15.9	18.8	22.5	31.8	39.0	50.3	59.6	71.2			

TYPICAL APPLICATIONS

Washing: exhaust scrubbers, small tanks, pipes interiors  
 Other applications: pipes coating, dust control, fire protection

HOW TO MAKE UP THE NOZZLE CODE  
 EX.: RCY 1780 B1

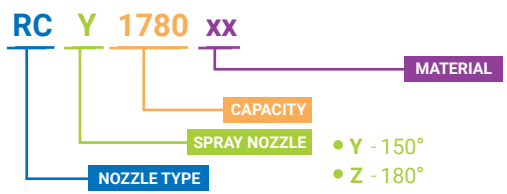

- B1 - AISI 303 Stainless steel
- T1 - Brass
- B31 - AISI 316L Stainless steel (on request)

# RO (HOLLOW CONE NOZZLES / DEFLECTED SPRAY)

## DEFLECTED SPRAY

RO hollow cone deflected spray nozzles are specially designed for fire-fighting engineering. They produce an excellent water atomization and their deflected jet assures a wide spray coverage. The spray pattern is formed by the liquid flowing from the nozzle orifice over the surface of the below deflector with a special slotted design. All RO nozzles are certified by the EU fire regulations.

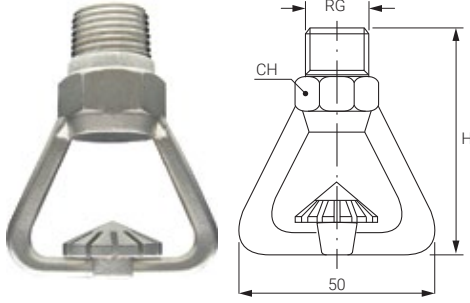

THREAD SPECIFICATION: BSPT, NPT  
 TYPICAL APPLICATIONS  
*Fire-fighting:* fire extinguishing, cooling  
*Other applications:* tank cleaning, exhaust scrubbers

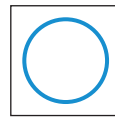

Spray section

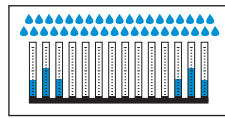

Concave distribution



ANGLE	CODE	RG inch	D mm	Capacity at different pressure values (l/min) (bar)						CH mm	H mm
				1.0	3.0	5.0	6.0	7.0	10.0		
130°	ROY D005 xx yy	1/2"	3.0	4.80	8.10	10.3	11.3	12.2	14.5	25	65
	ROY D006 xx yy		3.5	6.70	11.5	14.9	16.4	17.6	20.5		
	ROY D009 xx yy		4.0	9.00	15.6	20.0	22.0	24.0	29.0		
	ROY D011 xx yy		4.5	11.5	19.8	25.0	28.0	30.0	36.0		
	ROY D016 xx yy		5.0	15.8	27.0	35.0	39.0	42.0	50.0		
	ROY D018 xx yy		5.5	18.0	30.0	40.0	44.0	48.0	57.0		
	ROY D023 xx yy		6.0	23.0	39.0	50.0	55.0	60.0	71.0		
	ROY D027 xx yy		6.5	27.0	47.0	61.0	66.0	72.0	86.0		
	ROY D032 xx yy		7.0	31.0	55.0	72.0	77.0	84.0	91.0		
	ROY D041 xx yy		8.0	41.0	70.0	92.0	103	112	130		
	ROY D052 xx yy		9.0	52.0	91.0	117	129	140	165		
	ROY D064 xx yy		10.0	64.0	110	139	152	165	200		
	ROY D095 xx yy		12.0	95.0	164	214	236	255	290		
ROY D103 xx yy	13.0	103	178	230	252	272	325				
130°	ROY E005 xx yy	3/4"	3.0	4.80	8.10	10.3	11.3	12.2	14.5	27	65
	ROY E006 xx yy		3.5	6.70	11.5	14.9	16.4	17.6	20.5		
	ROY E009 xx yy		4.0	9.00	15.6	20.0	22.0	24.0	29.0		
	ROY E011 xx yy		4.5	11.5	19.8	25.0	28.0	30.0	36.0		
	ROY E016 xx yy		5.0	15.8	27.0	35.0	39.0	42.0	50.0		
	ROY E018 xx yy		5.5	18.0	30.0	40.0	44.0	48.0	57.0		
	ROY E023 xx yy		6.0	23.0	39.0	50.0	55.0	60.0	71.0		
	ROY E027 xx yy		6.5	27.0	47.0	61.0	66.0	72.0	86.0		
	ROY E032 xx yy		7.0	31.0	55.0	72.0	77.0	84.0	91.0		
	ROY E041 xx yy		8.0	41.0	70.0	92.0	103	112	130		
	ROY E052 xx yy		9.0	52.0	91.0	117	129	140	165		
	ROY E064 xx yy		10.0	64.0	110	139	152	165	200		
	ROY E095 xx yy		12.0	95.0	164	214	236	255	290		
ROY E103 xx yy	13.0	103	178	230	252	272	325				

### COMPLETE NOZZLE CODE

CODE	Thread	Filter	
		Copper	None
FB	BSPT	•	
FN	NPT	•	
SB	BSPT		•
SN	NPT		•

### HOW TO MAKE UP THE NOZZLE CODE

Ex.: ROY D018 B31FB

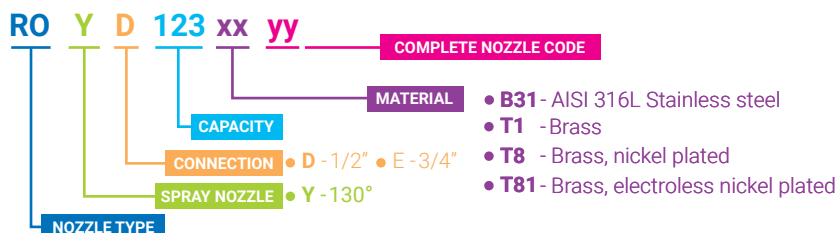



# ( HOLLOW CONE NOZZLES ) RW / RX / RZ

## HYDRAULIC ATOMIZERS

RX/RZ series hydraulic nozzles deliver a very finely atomized hollow cone spray, even at low pressure values. They contain a precisely machined insert with narrow passages that can be easily disassembled for cleaning in case of obstruction. Clogging can be avoided placing a fine mesh strainer on the main manifold or using an individual filter.

RW hydraulic atomizers works in the same way, but the tip is locked with a welded nipple ZAA and a locknut VAA. The capacities of RW tip are the same of RX nozzle. To have the complete product code, just change "RX" with "RW".

### CONNECTION

BSPT (RX), BSP (RZ), NPT (RX, RZ), tip with nipple and locknut (RW)

### TYPICAL APPLICATIONS

Dust control, humidification, deodorant spray, disinfectant liquid spray, exhaust scrubbers

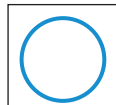

Spray section

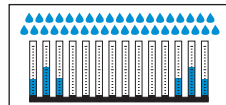

Concave distribution

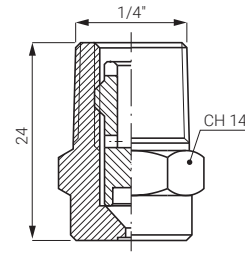

RX

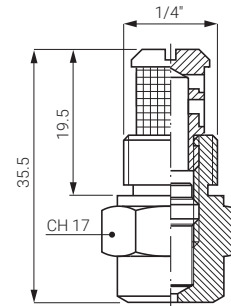

RZ (+VEF)

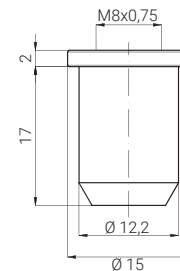

RW

80°	CODE	D mm	Capacity (l/hour) at different pressure values (bar)									
			1.5	2.0	3.0	4.0	5.0	6.0	10	15	20	50
	RXT 0060 xx	0.50	2.55	2.94	3.60	4.16	4.65	5.09	6.57	8.05	9.30	14.7
	RXT 0100 xx	0.50	4.24	4.90	6.00	6.93	7.75	8.49	11.0	13.4	15.5	24.5
	RXT 0130 xx	0.70	5.52	6.37	7.80	9.01	10.1	11.0	14.2	17.4	20.1	31.8
	RXT 0190 xx	0.70	8.06	9.31	11.4	13.2	14.7	16.1	20.8	25.5	29.4	46.5
	RXT 0250 xx	1.00	10.6	12.2	15.0	17.3	19.4	21.2	27.4	33.5	38.7	61.2
	RXT 0380 xx	1.00	16.1	18.6	22.8	26.3	29.4	32.2	41.6	51.0	58.9	93.1
	RXT 0510 xx	1.50	21.6	25.0	30.6	35.3	39.5	43.3	55.9	68.4	79.0	125
	RXT 0650 xx	1.60	27.6	31.8	39.0	45.0	50.3	55.2	71.2	87.2	101	159
	RXT 0780 xx	1.90	33.1	38.2	46.8	54.0	60.4	66.2	85.4	105	121	191
	RXT 0910 xx	1.90	38.6	44.6	54.6	63.0	70.5	77.2	99.7	122	141	223
	RXT 1116 xx	1.90	49.2	56.8	69.6	80.4	89.9	98.4	127	156	180	284
	RXT 1143 xx	1.90	60.7	70.1	85.8	99.1	111	121	157	192	222	350
	RXT 1166 xx	2.20	70.4	81.3	99.6	115	129	141	182	223	257	407

### FILTRI FILETTATI VEF



We suggest to use a VEF threaded filter to protect the nozzle against clogging.

60°	CODE	D mm	Capacity (l/min) at different pressure values (bar)									
			1.5	2.0	3.0	4.0	5.0	6.0	10	15	20	50
	RZQ 0080 xx	0.45	0.06	0.07	0.08	0.09	0.10	0.11	0.15	0.18	0.21	0.33
	RZQ 0120 xx	0.55	0.08	0.10	0.12	0.14	0.15	0.17	0.22	0.27	0.31	0.49
	RZQ 0250 xx	0.80	0.18	0.20	0.25	0.29	0.32	0.35	0.46	0.56	0.65	1.02
	RZQ 0390 xx	1.00	0.28	0.32	0.39	0.45	0.50	0.55	0.71	0.87	1.01	1.59
	RZQ 0560 xx	1.20	0.40	0.46	0.56	0.65	0.72	0.79	1.02	1.25	1.45	2.29
	RZQ 0780 xx	1.40	0.55	0.64	0.78	0.90	1.01	1.10	1.42	1.74	2.01	3.18
	RZQ 1100 xx	1.60	0.71	0.82	1.00	1.15	1.29	1.41	1.83	2.24	2.58	4.08
	RZQ 1140 xx	1.90	0.99	1.14	1.40	1.62	1.81	1.98	2.56	3.13	3.61	5.72
	RZQ 1170 xx	2.10	1.20	1.39	1.70	1.96	2.19	2.40	3.10	3.80	4.39	6.94
	RZQ 1200 xx	2.30	1.41	1.63	2.00	2.31	2.58	2.83	3.65	4.47	5.16	8.16

### ADDITIONAL SPRAY ANGLES

The spray angle of the RZQ nozzles is 60° with orifice dimensions larger than 1.0 mm.

RZF	RZM	RZQ	RZU
30°	45°	60°	90°

### HOW TO MAKE UP THE NOZZLE CODE

Ex.: RXT 0060 B1

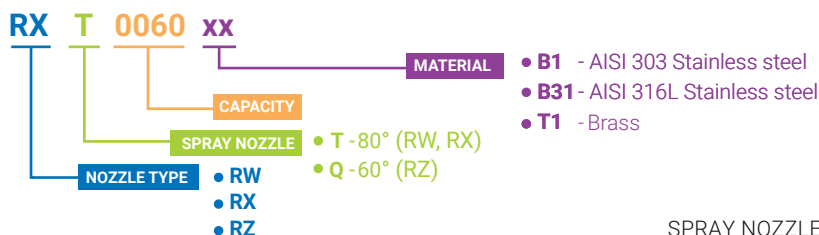



# STRAIGHT JET NOZZLES

## CONCENTRATED HIGH IMPACT FORCE

Solid stream nozzles provide a sharp and concentrated high pressure spray jet. These nozzles offer a stronger impact force than other types at the same operating pressures and flow rates.

## HIGHLY EXTENDED SERVICE LIFE

Solid stream nozzles are designed for applications requiring medium or high liquid pressures. High pressures may shorten nozzles service life. After a long research and many application tests, our engineers found out that ruby with a second hardness level is the ideal material to overcome this problem and extend nozzles durability as it resists abrasion or scratching. The nozzle tips are precisely machined and polished to ensure a perfect solid stream and enhance performance.



## SELF-CLEANING SHOWER PIPE AND NOZZLES

Paper making requires a great deal of water. Waste water is often reused to clean filters and felts to save costs and reduce water consumption. Reclaimed water contains solids and impurities that cause nozzles clogging and shutdowns for maintenance. Self-cleaning spray pipes and nozzles are the best solution to this. Their revolutionary design helps improving a great deal both production efficiency and industrial competitiveness.

*Self-cleaning spray pipes contain a rotating steel brush which can be automatically or manually operated and an escape valve at their outlet. The rotating brush removes all the dirt from the pipe walls using water.*

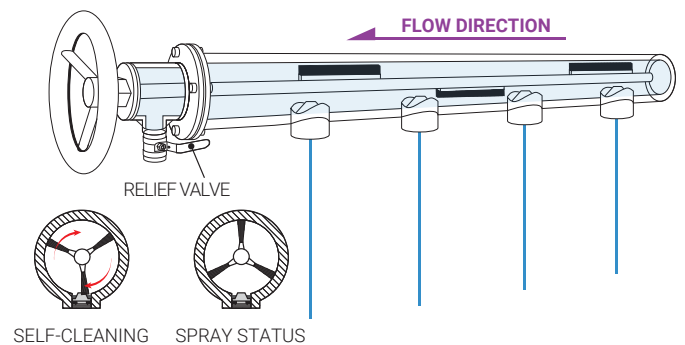

The nozzle body contains a mobile piston and its opening and closing are controlled by the operating water pressure. For example, when nozzles wash mesh fabrics with an operating pressure of 3 bar, this pressure is higher than a spring force of 1 bar. Piston and nozzle body come close producing a flat fan. If the inlet pressure is reduced to 0.5 bar, lower than a spring force of 1 bar, piston and nozzle body separate opening to the maximum distance. Water pressure remains at 0.5 bar and removes any build up when back to normal condition. Self-cleaning nozzles are easy to install, align and clean and ensuring relevant time and costs savings. The spring force is set depending on customer's plant working pressure.

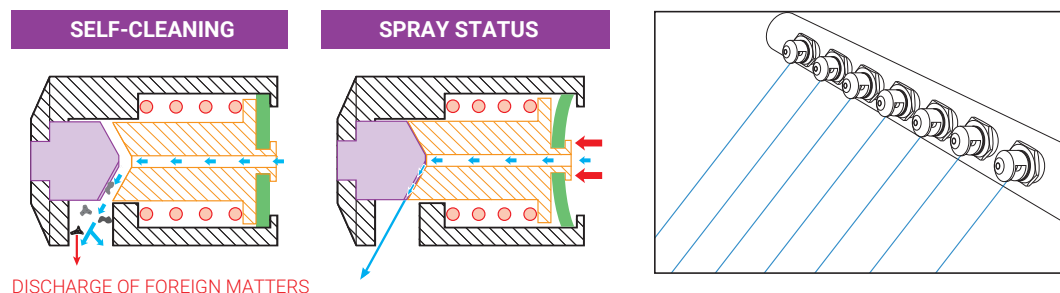

# (STRAIGHT JET NOZZLES) FAA / FBA

## FAA / FBA HIGH IMPACT SOLID STREAM NOZZLES

FAA/FBA types nozzles are specially designed for high pressure cleaning and washing operations. They are made in Stainless Steel 416, accurately machined and perfectly polished. They are particularly hard, resistant to wear, have a long service life and offer high precision performances.

THREAD SPECIFICATION: BSPT, NPT

TYPICAL APPLICATIONS

*Washing:* filter cloth, felts, parts.

*Other applications:* paint scraping, rust removal, shell removal.

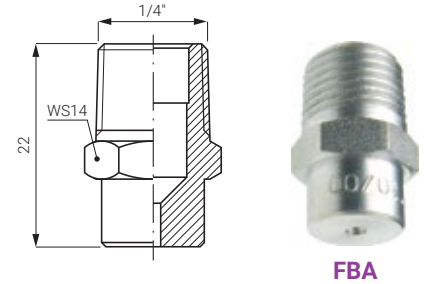
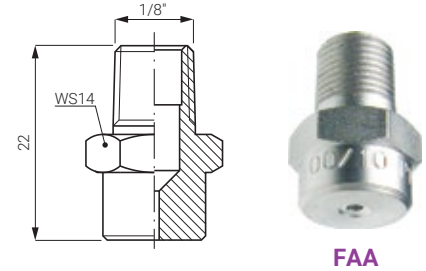
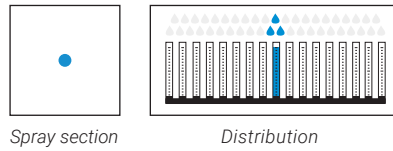
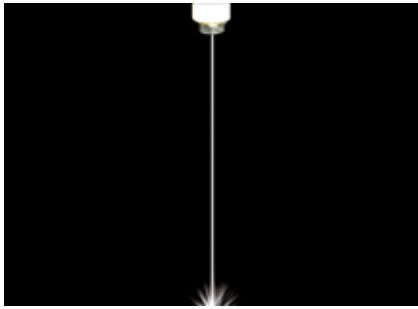

Nozzle type			US GALS	PNR CODE	Capacity at different pressure values (l/min) (bar)						
FAA 1/8"	FBA 1/4"	FXA			20	30	50	70	100	150	200
•	•	•	015	<b>1340</b>	1.52	1.86	2.40	2.84	3.40	4.16	4.81
•	•	•	02	<b>1460</b>	2.06	2.52	3.25	3.85	4.60	5.63	6.51
•	•	•	025	<b>1560</b>	2.50	3.07	3.96	4.69	5.60	6.86	7.92
•	•	•	03	<b>1686</b>	3.07	3.76	4.85	5.74	6.86	8.40	9.70
•	•	•	035	<b>1812</b>	3.63	4.45	5.74	6.79	8.12	9.94	11.5
•	•	•	04	<b>1930</b>	4.16	5.09	6.58	7.78	9.30	11.4	13.2
•	•	•	045	<b>2103</b>	4.61	5.64	7.28	8.62	10.3	12.6	14.6
•	•	•	05	<b>2116</b>	5.19	6.35	8.20	9.71	11.6	14.2	16.4
•	•	•	055	<b>2126</b>	5.63	6.90	8.91	10.5	12.6	15.4	17.8
•	•	•	06	<b>2138</b>	6.17	7.56	9.76	11.5	13.8	16.9	19.5
•	•	•	065	<b>2149</b>	6.66	8.16	10.5	12.5	14.9	18.2	21.1
•	•	•	07	<b>2160</b>	7.16	8.76	11.3	13.4	16.0	19.6	22.6
•	•	•	075	<b>2170</b>	7.60	9.31	12.0	14.2	17.0	20.8	24.0
•	•	•	08	<b>2181</b>	8.09	9.91	12.8	15.1	18.1	22.2	25.6
•	•	•	085	<b>2192</b>	8.59	10.5	13.6	16.1	19.2	23.5	27.2
•	•	•	09	<b>2204</b>	9.12	11.2	14.4	17.1	20.4	25.0	28.8
•	•	•	095	<b>2220</b>	9.84	12.1	15.6	18.4	22.0	26.9	31.1
•	•	•	10	<b>2230</b>	10.3	12.6	16.3	19.2	23.0	28.2	32.5
•	•	•	11	<b>2248</b>	11.1	13.6	17.5	20.7	24.8	30.4	35.1
•	•	•	12	<b>2272</b>	12.2	14.9	19.2	22.8	27.2	33.3	38.5
•	•	•	12.5	<b>2280</b>	12.5	15.3	19.8	23.4	28.0	34.3	39.6
•	•	•	13	<b>2296</b>	13.2	16.2	20.9	24.8	29.6	36.3	41.9
•	•	•	14	<b>2320</b>	14.3	17.5	22.6	26.8	32.0	39.2	45.3
•	•	•	15	<b>2341</b>	15.2	18.7	24.1	28.5	34.1	41.8	48.2
•	•	•	16	<b>2360</b>	16.1	19.7	25.5	30.1	36.0	44.1	50.9
•	•	•	18	<b>2410</b>	18.3	22.5	29.0	34.3	41.0	50.2	58.0
•	•	•	20	<b>2456</b>	20.4	25.0	32.2	38.2	45.6	55.8	64.5
•	•	•	25	<b>2567</b>	25.4	31.1	40.1	47.4	56.7	69.4	80.2
•	•	•	30	<b>2682</b>	30.5	37.4	48.2	57.1	68.2	83.5	96.4
•	•	•	35	<b>2800</b>	35.8	43.8	56.6	66.9	80.0	98.0	113
•	•	•	40	<b>2910</b>	40.7	49.8	64.3	76.1	91.0	111	128
•	•	•	50	<b>3113</b>	50.5	61.9	79.9	94.5	113	138	160
•	•	•	60	<b>3135</b>	60.4	73.9	95.5	113	135	165	191

HOW TO MAKE UP THE NOZZLE CODE PRODUCT IDENTIFICATION CODE

The above table shows the "American Capacity Code", that is, the capacity in Gallons per minute at an operating pressure of 40 psi, and the "PNR Capacity Code" (in Litres/min) at a capacity of 100 bar. For the convenience of worldwide use, all nozzles are expressed with the US coding system.

For Example: nozzle **FBA 1686 C2** (PNR code) will be codified as **"00/03"**(US Gallons) with a spray angle 0° and capacity 0.3 Gals/min at a pressure of 40 psi.

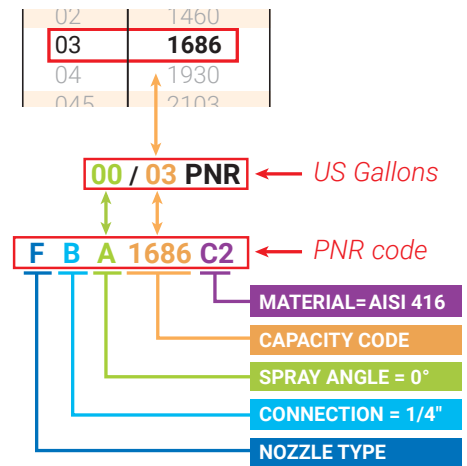

### FLOW STABILIZER

Flow stabilizers are used to improve the stability of the liquid flow as they reduce losses caused by internal turbulence and allow to use a higher percentage of the liquid vein energy to generate a high impact solid flat fan. Flow stabilizers can be installed on all nozzles.



# GD (STRAIGHT JET NOZZLES)

## GDA SERIES NEEDLE JET NOZZLES

GDA models are classic high impact needle jet nozzles, easy to clean and clog-resistant. Their tips spray a solid stream of high pressure water inside pipes usually containing a steel brush that can be manually or automatically rotated. The rotating brush moving inside the pipe takes all the dirt off the inner walls and then flushes out the debris through an escape valve. For their revolutionary design, GDA nozzles are ideal for high pressure cleaning in paper mills and in all industrial processes requiring a high impact needle spray jet. Their resistance to clogging ensures greater productivity and low servicing costs.



THREAD SPECIFICATION: BSPT, 9/16-24NEF  
TYPICAL APPLICATIONS

*Washing:* filter cloth washing, woolen blanket washing, parts washing  
*Other applications:* scrape paint, rust removal

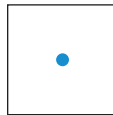

Spray section

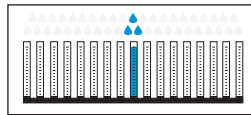

Distribution

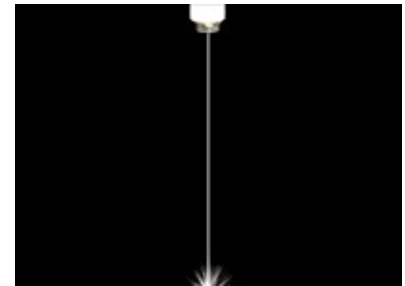

**GDA needle jet nozzles** are a one-piece construction, suitable to work with operating pressures lower than 20 bar and have a hard ruby spray tip, ideal to work with pressures lower than 200 bar. They are precisely machined and have a hydrodynamic design to produce a solid stream needle jet. Their stainless steel body and ruby tip ensure a long service life and a high resistance to wear.

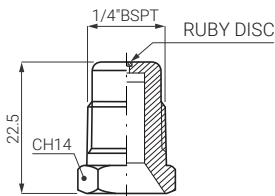

RUBY NOZZLE TIP

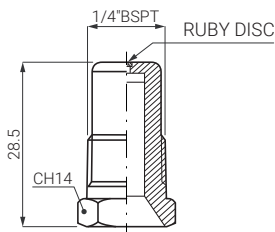

RUBY NOZZLE TIP

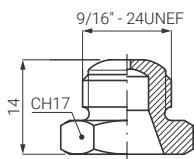

METAL / RUBY NOZZLE TIP

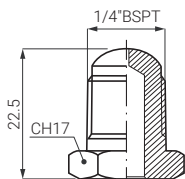

METAL

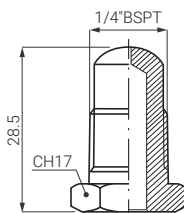

METAL

Nozzle type		CODE	D mm	Capacity at different pressure values (l/min) (bar)									
Stainless steel	Ruby insert			3.0	5.0	10	20	30	50	70	100	150	
•		GDA 0120 xx xy	0.35	0.12	0.15	0.22	0.31						
•	•	GDA 0170 xx xy	0.40	0.17	0.22	0.31	0.44	0.54	0.69	0.82	0.98	1.20	
•	•	GDA 0290 xx xy	0.50	0.29	0.37	0.53	0.75	0.92	1.18	1.40	1.67	2.05	
•	•	GDA 0320 xx xy	0.60	0.32	0.41	0.58	0.83	1.01	1.31	1.55	1.85	2.26	
•	•	GDA 0420 xx xy	0.70	0.42	0.54	0.77	1.08	1.33	1.71	2.03	2.42	2.97	
•	•	GDA 0500 xx xy	0.80	0.50	0.65	0.91	1.29	1.58	2.04	2.42	2.89	3.54	
•	•	GDA 0620 xx xy	0.85	0.62	0.80	1.13	1.60	1.96	2.53	2.99	3.58	4.38	
•	•	GDA 0780 xx xy	0.90	0.78	1.01	1.42	2.01	2.47	3.18	3.77	4.50	5.52	
•	•	GDA 0890 xx xy	1.00	0.89	1.15	1.62	2.30	2.81	3.63	4.30	5.14	6.29	
•	•	GDA 1120 xx xy	1.10	1.20	1.55	2.19	3.10	3.79	4.90	5.80	6.93	8.49	
•	•	GDA 1153 xx xy	1.20	1.53	1.98	2.79	3.95	4.84	6.25	7.39	8.83	10.8	
•		GDA 1160 xx xy	1.40	1.60	2.07	2.92	4.13						
•		GDA 1270 xx xy	1.80	2.70	3.49	4.93	6.97						
•		GDA 1450 xx xy	2.40	4.50	5.81	8.22	11.6						
•		GDA 1730 xx xy	3.20	7.30	9.42	13.3	18.8						

COMPLETE NOZZLE CODE	
<b>x</b> = Body length	<b>y</b> = Thread
<b>A</b> for 14.0 mm	<b>A</b> for 1/4" BSPT
<b>B</b> for 28.5 mm	<b>B</b> for 9/16 - 24 UNEF
<b>C</b> for 22.5 mm	

**GD nozzles** are installed with their spray tips inside the pipe that spray in high pressure fluids producing turbulence to remove all dirt off the inner pipe walls. Used in combination with self-cleaning pipes, these nozzles assure complete cleaning, productivity improvement, minimal maintenance.

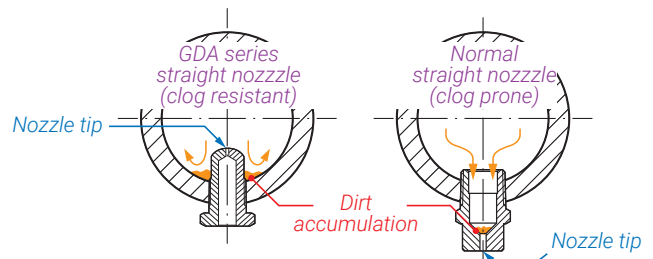

HOW TO MAKE UP THE NOZZLE CODE  
EX.: GDA 0120 B1AA

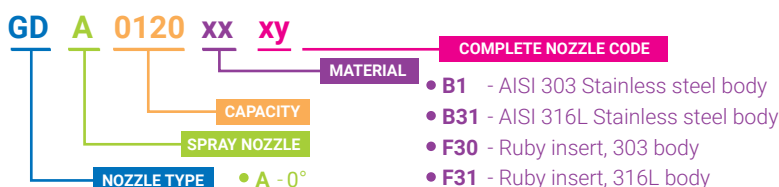

( STRAIGHT NOZZLES / PAPER WEB TRIMMERS ) **GMA**

GMA SERIES PAPER WEB TRIMMERS

GMA nozzles produce a glass-rod like needle jet, ideal in paper mills to cut and trim the side of your paper web with a sharp edge, precise, clean and with no dust. They are precisely machined. Their smooth high quality ruby tip and special design produce a solid straight jet for precision trimming. A 150 mesh stainless steel filter avoids clogging. Their stainless steel body and ruby spray tip assures a long service life.

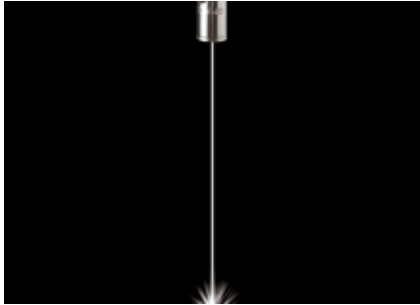

THREAD SPECIFICATION: 3/8" BSPT, 3/8" NPT  
 FILTERING FINENESS: 150 Mesh  
 TYPICAL APPLICATIONS  
 Felt and wire cleaning  
 Parts washing NP

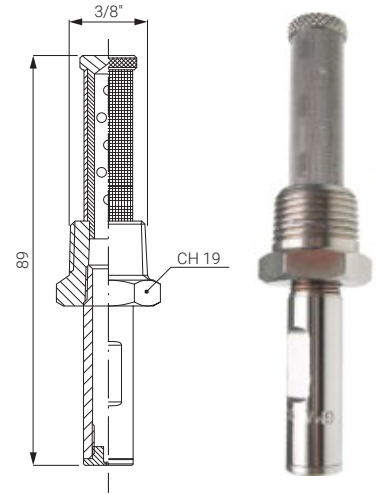
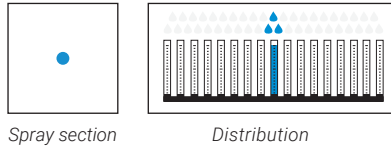

	CODE	D mm
0°	<b>GMA 0380 <i>xy</i></b>	0.381
	<b>GMA 0500 <i>xy</i></b>	0.508
	<b>GMA 0630 <i>xy</i></b>	0.635
	<b>GMA 0810 <i>xy</i></b>	0.810
	<b>GMA 0890 <i>xy</i></b>	0.889
	<b>GMA 0910 <i>xy</i></b>	0.914
	<b>GMA 1010 <i>xy</i></b>	1.016
	<b>GMA 1220 <i>xy</i></b>	1.219

**NEW CODE**

GMA codes have been modified, based on the orifice diameter, measured for every nozzle. Please contact use if you need the capacity at different pressure.

PERFECT CLEANING

GMA top quality ruby tips produce a solid needle spray jet to trim paper web with a precise and sharp edge cut.

PAPER MACHINE TRIMMING

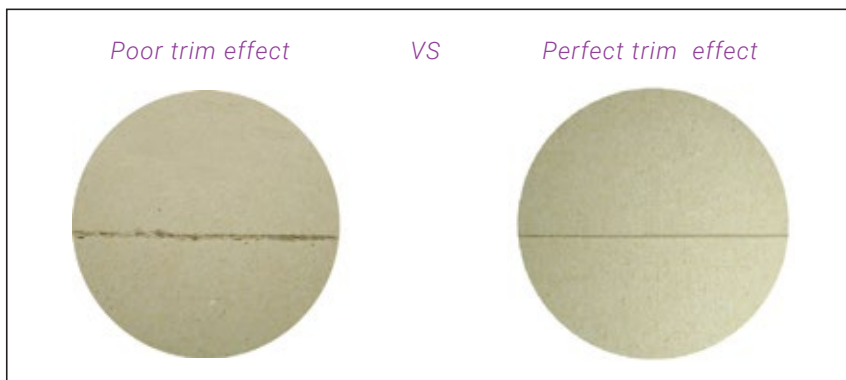

**HOW TO MAKE UP THE NOZZLE CODE**  
 Ex.: GMA 0380 F30B

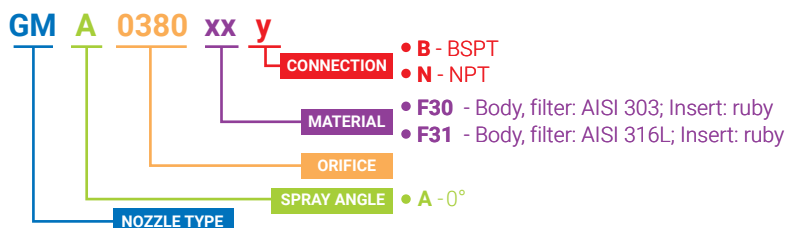



# JAA / JBA ( STRAIGHT JET NOZZLES )

## JAA/JBA HIGH IMPACT STRAIGHT JET NOZZLES

J type high impact straight jet nozzles are a one-piece construction in stainless steel, suitable to work with pressures lower than 20 bar, and have a ruby spray tip suitable for operating pressures lower than 200 bar. The two types, JAA and JBA, have a special hydrodynamic design and are machined with high precision to produce a solid needle jet. Their stainless steel body is highly resistant to chemicals and wear and assure a long service life.

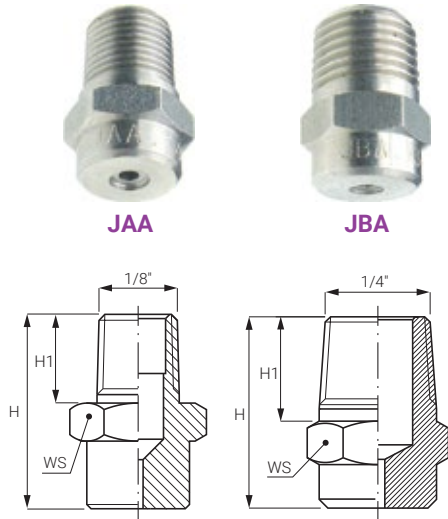

THREAD SPECIFICATION: BSPT

TYPICAL APPLICATIONS

*Washing:* Felts, filter cloths and parts washing

*Other applications:* Paint scraping  
Rust and shell removal

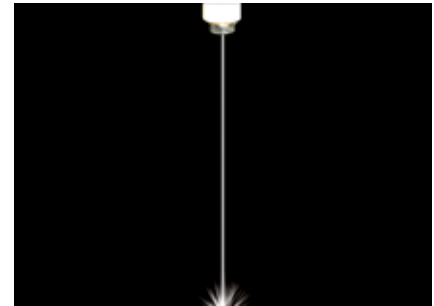
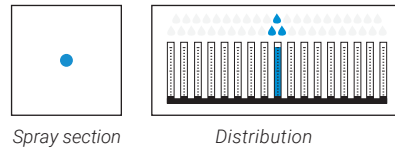

### DIMENSIONS AND WEIGHTS

CODE	Dimension	H	H1	WS	W
unit	inch	mm	mm	mm	gr
JA	1/8"	19.5	11	12	9
JB	1/4"	22.0	12	14	18
JC	3/8"	25.0	14	17	34

Nozzle type			CODE	D	Capacity at different pressure values (l/min) (bar)			
JAA (1/8")	JBA (1/4")	JCA (3/8")			3.0	5.0	10	20
•	•		0060	0.28	0.06	0.08	0.11	0.15
•	•		0100	0.34	0.10	0.13	0.18	0.26
•	•		0130	0.38	0.13	0.17	0.24	0.34
•	•		0150	0.40	0.15	0.19	0.27	0.39
•	•		0200	0.46	0.20	0.26	0.37	0.52
•	•		0260	0.53	0.26	0.34	0.47	0.67
•	•		0390	0.66	0.39	0.50	0.71	1.01
•	•		0590	0.79	0.59	0.76	1.08	1.52
•	•		0780	0.91	0.78	1.01	1.42	2.01
•	•		1120	1.10	1.20	1.55	2.19	3.10
•	•		1160	1.30	1.60	2.07	2.92	4.13
•	•		1190	1.30	1.90	2.45	3.47	4.91
•	•		1233	1.50	2.33	3.01	4.25	6.02
•	•		1310	1.70	3.10	4.00	5.66	8.00
•	•		1385	1.80	3.85	4.97	7.03	9.94
•	•		1490	2.10	4.90	6.33	8.95	12.7
•	•		1581	2.30	5.81	7.50	10.6	15.0
•	•	•	1780	2.70	7.80	10.1	14.2	20.1
•	•	•	1980	3.00	9.80	12.7	17.9	25.3
•	•	•	2124	3.40	12.4	16.0	22.6	32.0
•	•	•	2153	3.80	15.3	19.8	27.9	39.5
	•	•	2195	4.30	19.5	25.2	35.6	50.3
	•	•	2245	4.80	24.5	31.6	44.7	63.3
	•	•	2274	5.20	27.4	35.4	50.0	70.7
	•	•	2310	5.40	31.0	40.0	56.6	80.0
	•	•	2390	6.00	39.0	50.3	71.2	101
	•	•	2470	6.20	47.0	60.7	85.8	121

### HOW TO MAKE UP THE NOZZLE CODE

Ex.: JAA 0170 B1

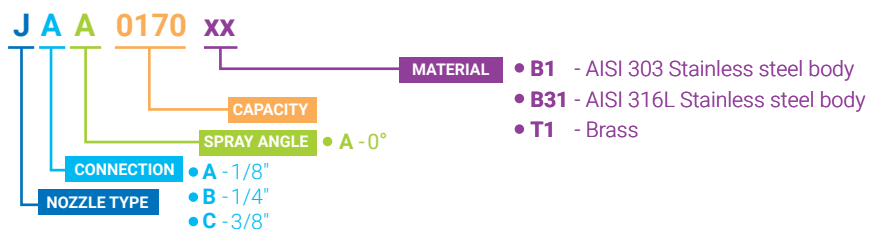

( AIR & STEAM FLAT FAN TIPS ) **GZS**

AIR & STEAM FLAT FAN TIPS

GZ air & steam flat fan tips are ideal for gas application. They are widely used in drying processes.

CONNECTION:  
flanged nozzle tip

TYPICAL APPLICATIONS:  
water removal from surfaces, flocks and water blow off

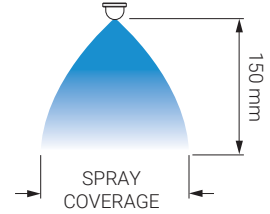
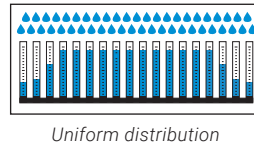
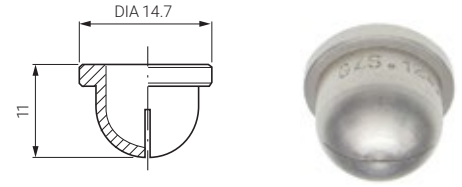

70°	CODE	D mm	Air capacity (Nm <sup>3</sup> /hour) at different pressure values (bar)				Steam capacity (kg/hour) at different pressure values (bar)				Spray coverage mm	
			0.5 bar	2.0 bar	5.0 bar	10 bar	0.5 bar	2.0 bar	5.0 bar	10 bar	2.0 bar	5.0 bar
	<b>GZS 1300 xx</b>	1.3	1.2	3.0	6.0	11.0	0.9	1.9	3.7	6.7	70	85
	<b>GZS 1350 xx</b>	1.5	2.0	3.5	7.1	12.6	1.0	2.1	4.1	7.7	72	87
	<b>GZS 1500 xx</b>	1.8	2.3	5.3	10.7	19.5	1.7	3.3	6.6	11.8	110	125
	<b>GZS 1800 xx</b>	2.1	3.2	8.0	16.0	29.0	2.5	5.0	9.9	18.0	115	140
	<b>GZS 2150 xx</b>	2.8	5.4	13.0	26.0	48.0	4.2	8.2	16.0	29.0	130	170
	<b>GZS 2200 xx</b>	3.6	8.9	21.7	43.3	79.4	6.8	13.6	27.0	48.0	140	180
	<b>GZS 2315 xx</b>	4.3	13.0	31.8	65.6	120.2	10.3	20.6	40.4	73.0	170	215

ASSEMBLY FITTINGS

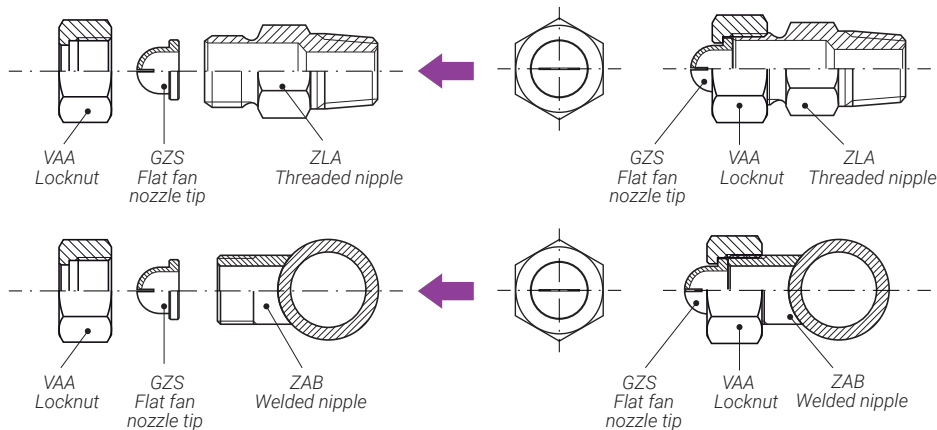

HOW TO MAKE UP THE NOZZLE CODE

EX.: GZS 1300 B1

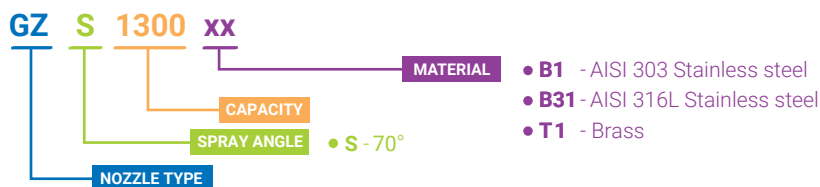

# UEA D020 ( FULL CONE NOZZLES )

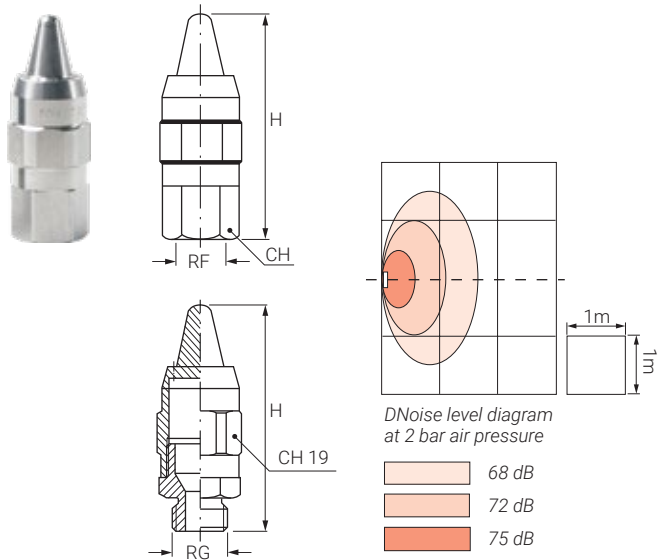

## AIR BLOW-OFF NOZZLES, ROUND JET

UEA D020 compressed air blowing nozzles produce a powerful air jet concentrated on a well defined impact point. They are specially designed for deep and blind holes drying, produce lower noise and reduce pressure loss.

THREAD SIZE 1/4"  
 THREAD SPECIFICATION BSP, NPT  
 MATERIAL **V7** Aluminium, electroless nickel plated  
**B31** AISI 316L Stainless steel  
 TYPICAL APPLICATIONS Water removal from surfaces  
 Flocks and water blow off

CODE	RF inch	Air capacity at different pressure values (Nm <sup>3</sup> /hour) (bar)					H mm	WS mm
		2.0	3.0	4.0	5.0	6.0		
UEA D020 xx yy	1/4"	15	20	25	31	35	55	17

HOW TO MAKE UP THE NOZZLE CODE Ex.: UEA D020 B31SG

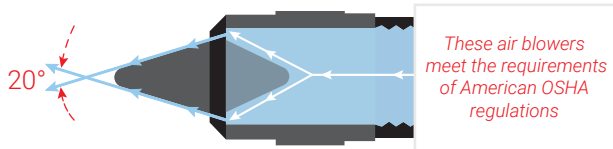

# UEA 0525 / 0527 ( AIR BLOWERS - FLAT FAN )

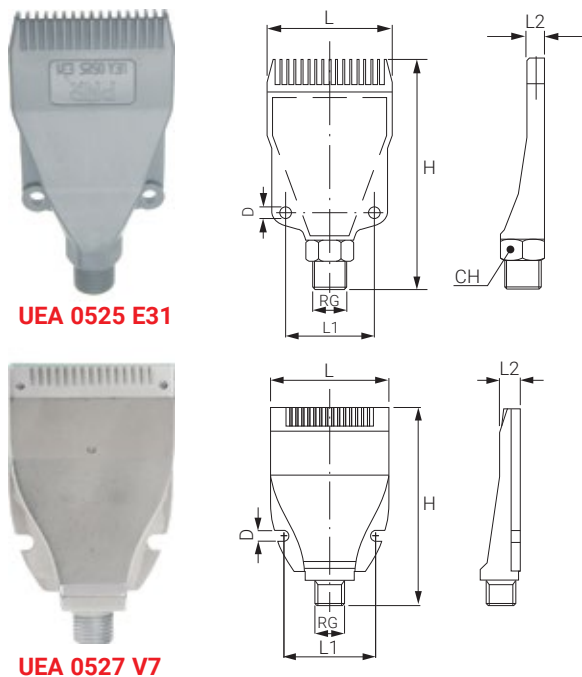

## AIR BLOWERS, FLAT FAN

UEA series compressed air blowers are the best choice for operating environments requiring strong impact laminar sprays. The compressed air flow is blown through 16 orifices producing a strong impact jet, limited noise level and uniform spray. They are suitable to be installed on moving conveyors.

THREAD SIZE 1/4"  
 THREAD SPECIFICATION BSPT, NPT  
 MATERIAL **E31** Polyacetalic resin (POM)  
**V7** Aluminium, electroless nickel plated  
**B31** AISI 316L s.s.  
 TYPICAL APPLICATIONS Water removal from surfaces  
 Flocks and water blow off

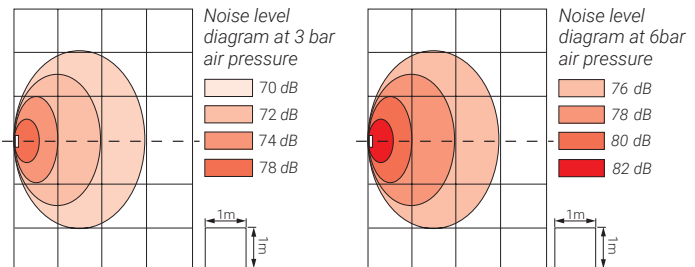

NEW! Also available in AISI 316L

CODE	RG inch	Air capacity at different pressure values (Nm <sup>3</sup> /hour) (bar)					H mm	L mm	L1 mm	L2 mm	D mm	WS mm
		1.0	2.0	3.0	4.0	5.0						
UEA 0525 E31 yy	1/4"	10	17	22	28	---	90.0	47	25	6.5	5.0	16
UEA 0527 xx yy		10	17	22	28	33	86.5	51	41	6.5	5.1	17

HOW TO MAKE UP THE NOZZLE CODE Ex.: UEA 0525 E31SG

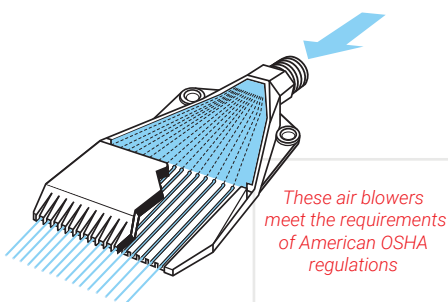
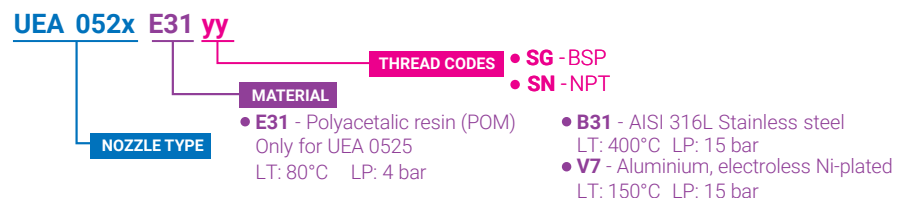

( AIR BLOWING NOZZLES ) **UEB**

HIGH EFFICIENCY AIR KNIVES

UEB air knives produce a high impact laminar jet of compressed air. They are fully adjustable and precisely engineered with a special design based on the Coanda effect, the natural tendency of a fluid jet to be attracted to a nearby surface. The air blade coming out through their side slot follows the radiused profile and leaves the blower body with a 90° angle from the original direction. The negative pressure brings in a 20 times bigger wind volume allowing a high energy saving. They offer an excellent drying performance and eliminate static electricity.

LENGTH: 150 mm, 300 mm, 450 mm, 600 mm

TYPICAL APPLICATIONS: Water removal from surfaces

- Flocks and water blow off
- Water removal before stick and print

MAX WORKING TEMPERATURE LT 95°C

MAX WORKING PRESSURE LP 7 bar

THREAD SPECIFICATION BSP, NPT

THREAD SIZE 1/4"

MATERIALS Body **V7** Aluminium,electroless nickel plated  
**B3** AISI 316L Stainless Steel  
 Upper plate **A9** Nickel plated steel  
**B3** AISI 316L Stainless Steel



**UEB 0150**

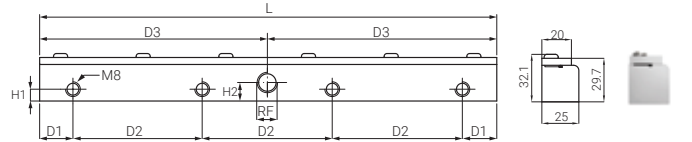

**UEB 0300**

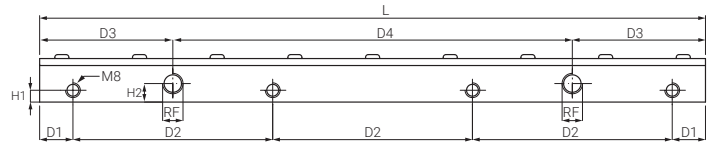

**UEB 0450 / UEB 0600**

CODE	RF inch	Air capacity (Nm <sup>3</sup> /min)										Dimensions						W kg	
		AE	AU	AE	AU	AE	AU	AE	AU	AE	AU	D1 mm	D2 mm	D3 mm	D4 mm	H1 mm	H2 mm		L mm
<b>UEB 0150 xx yy</b>	1/4"	0.26	4.70	0.34	6.00	0.42	7.10	0.51	8.60	0.60	10.6	20.0	110	75	-	8	12.5	150	0.3
<b>UEB 0300 xx yy</b>		0.52	9.40	0.68	12.0	0.84	14.2	1.02	17.2	1.20	21.2	22.5	85	150	-			300	0.7
<b>UEB 0450 xx yy</b>		0.78	14.1	1.03	18.0	1.26	21.3	1.53	25.8	1.80	31.8	22.5	135	90	270			450	0.9
<b>UEB 0600 xx yy</b>		1.03	18.7	1.40	24.0	1.68	28.4	2.04	34.4	2.40	42.4	22.5	185	150	300			600	1.4



The table shows the air capacity as a function of the air pressure whereas the below graphs show the noise level as a function of the front and side distances from the nozzle outlet at an operating pressure of 2 bar. The air flow leaving the nozzle orifice drags along ambient air, the air blade produced by the nozzle (AIR OUT) has a larger flow rate which is a multiple of the feed air flow (AIR IN).

SAVE ENERGY AND INCREASE THE AMOUNT OF WIND

The compressed air exits through the side slot following the radiused profile and leaves the body with an angle of 90° from the original direction. The negative pressure brings in 20 times wind volume and saves energy consumption greatly.

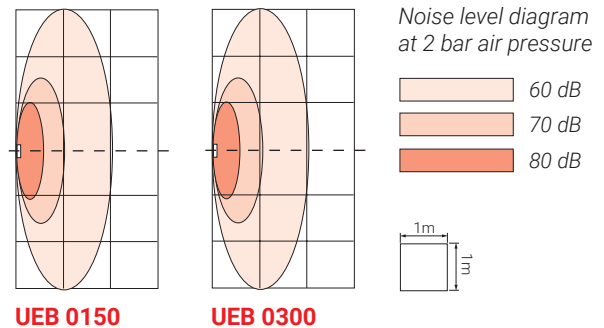
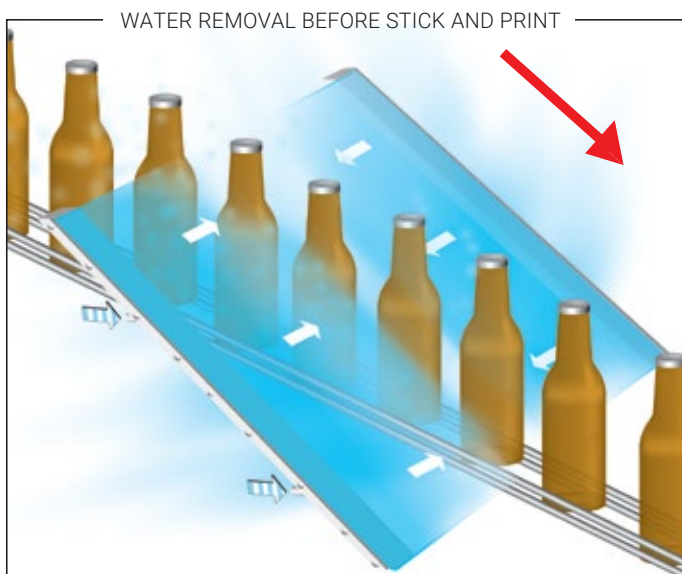

HOW TO MAKE UP THE NOZZLE CODE

Ex.: UEB 0150 V7SG

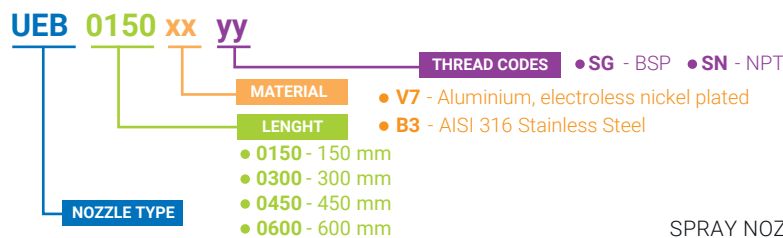

# UPB ( MIXING EDUCTORS )

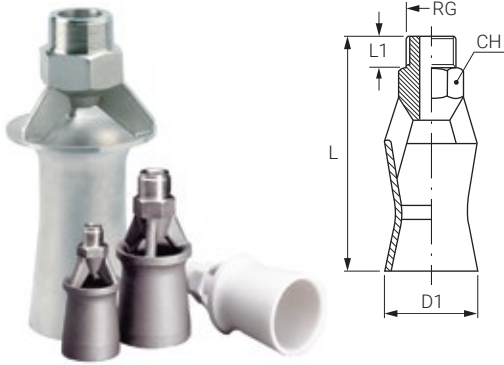

## MIXING EDUCTORS

UPB mixing eductors are energy saving products. Their robust bell-shaped body minimizes the risk of damage during maintenance operations and the Venturi design assures a high mixing efficiency. These eductors enable the circulation of large volumes of liquid and are ideal for continuous blending and stirring of liquids or solutions in tanks. The UPB eductors are installed at the bottom of a tank and pressurized to spray the solution. This flow creates a powerful negative pressure that allows to take in four times the liquid volume, mix it with a solution inside the nozzle and spray it back into the tank at a high speed. 1 HP pump and UPB mixing eductor can replace a 5 HP mixing eductor. UPB eductors are an efficient way to get the best performance from re-circulating process tanks and are cost-effective because they reduce the electrical costs.

STEAM CONSUMPTION CHART

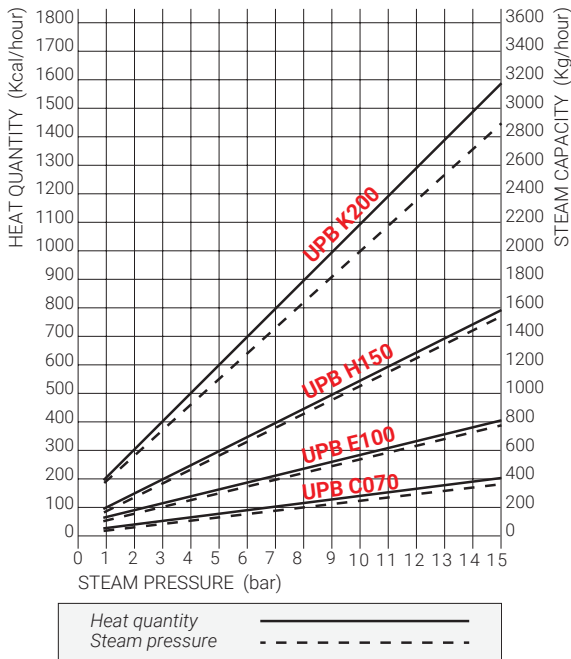

The table above shows the working condition of UPB C070 B31 eductor when set at 50 cm depth. We are at your disposal to realize UPB eductors on demand: PNR will give you the code and the dimensions.

TYPICAL APPLICATIONS Liquid mixing in electroplating and automotive paint factories  
 THREAD SPEC. BSPT (B, solo AISI), BSPP (G, PP & PVDF), NPT (N, all)  
 MAX WORKING TEMPERATURE LT 80 °C (PP), 90 °C (PVDF)  
 MATERIAL B31 AISI 316L Stainless Steel  
 D6 PP, chemically bonded fiberglass  
 D82 PVDF, moulded

CODE	RG inch	D mm	Flow rate at pressure (l/min) (bar)					D1 mm	L mm	L1 mm	WS mm
			1.0	2.0	3.0	4.0	5.0				
UPB B030 D82Sx	1/4"	3.0	5.9	8.2	9.9	11	13	38	78	---	---
UPB B030 D6Sx		3.0	5.9	8.2	9.9	11	13				
UPB B040 D6Sx		4.0	10	15	18	20	23				
UPB B050 D6Sx		5.0	16	22	27	31	35				
UPB C070 B31Sx	3/8"	7.0	34	48	59	68	76	45	98	15	22
UPB C070 D6Sx		7.0	34	48	59	68	76				
UPB C070 D82Sx		7.0	34	48	59	68	76				
UPB E100 B31Rx	1/2"	10.0	63	89	109	126	141	60	132	20	30
UPB E100 B31Sx	3/4"	10.0	63	89	109	126	141	60	132	20	30
UPB E100 D6Sx			63	89	109	126	141				
UPB H150 B31Sx	1 1/2"	15.0	155	215	265	305	340	110	225	30	60
UPB K200 B31Sx	2"	20.0	268	377	460	531	592	102	295	30	70

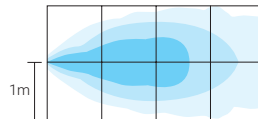

Under normal operating conditions, with feed pressure values ranging from 2 to 4 bars, eductors with a total capacity equal to 20% of the liquid volume to be stirred proved to be adequate for most industrial applications.

# UPD ( MIXING EDUCTORS )

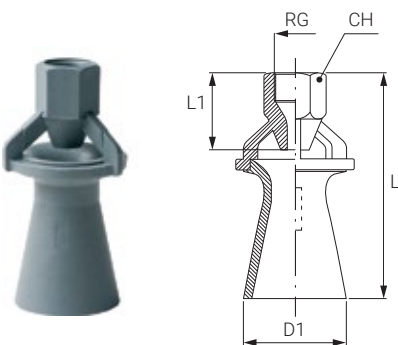

## MIXING EDUCTORS

UPD mixing eductors, whose design applies the "Coanda Effect", enable the circulation of large volumes of liquid. They are installed at the bottom of a tank and pressurized to spray the solution. This flow creates a powerful negative pressure that allows to take in four times the liquid volume, mix it with a solution inside the nozzle and spray it back into the tank at a high speed. 1 HP pump and UPB mixing eductor can replace a 5 HP mixing eductor. UPD eductors offer a high mixing efficiency and are cost effective because they save energy and are resistant to wear and corrosion. UPD eductors have the same technical features of the UPB models, but they come with a female thread connection.

THREAD SPECIFICATION BSP (G), NPT (N)  
 MATERIAL B31 AISI 316L Stainless Steel  
 D6 PP, PP, chemically bonded fiberglass  
 MAX WORKING TEMPERATURE LT 80 °C (PP)  
 TYPICAL APPLICATIONS Liquids mixing in electroplating, automotive painting, chemical plants.

CODE	RG inch	D mm	Flow rate at pressure (l/min) (bar)					D1 mm	L mm	L1 mm	WS mm
			1.0	2.0	3.0	4.0	5.0				
UPD E100 D6Sx	3/4"	10	63	89	109	126	141	75	147	30	34
UPD H150 D6Sx	1 1/2"	15	140	198	243	281	314	80	225	45	60
UPD H150 B31Sx	1 1/2"	15	155	215	265	305	340	80	239	83	60
UPD K200 B31Sx	2"	20	268	377	460	531	592	102	295	83	70

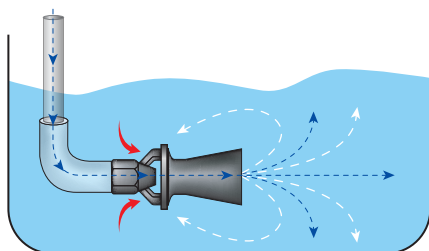



( PIPE CLAMPS ) **ZPB**

PLASTIC PIPE CLAMPS

ZPB plastic pipe clamps allow a quick, professional and convenient instalment of GX, BX or KX flanged nozzles onto manifolds. Using these clamps it's not necessary to weld nipples or use thick pipes, all you need is one hole in the pipe. ZPB body is made in PP reinforced glass fiber while screws and bolts are in stainless steel AISI 316 to assure a good corrosion resistance. VEA, VEC and VED flanged filters are available on request to prevent clogging.

TYPICAL APPLICATIONS	Pre-treatment for coating process Parts cleaning
MAX WORKING TEMPERATURE	LT 90°C
MAX WORKING PRESSURE	LP 8 bar
MATERIAL	Body <b>D6</b> PP, chemically bonded fiberglass O-ring <b>E8</b> NBR Metal parts <b>B2</b> AISI 304 Stainless Steel

CODE	RG inch	PS inch	PD mm	D mm	H mm	H1 mm	L mm	W g
ZPB 0050 D6SG	3/8"	1/2"	21 / 22	7,60	15,0	36,0	44,5	20,0
ZPB 0074 D6SG		-	25	7,60	19,0	39,0	51,5	24,0
ZPB 0075 D6SG		3/4"	26 / 27	7,60	19,0	39,0	51,5	26,0
ZPB 0100 D6SG		1"	33 / 34	10,0	23,0	46,0	62,0	30,0
ZPB 0125 D6SG		1-1/4"	42 / 43	12,0	35,0	55,0	85,0	75,0

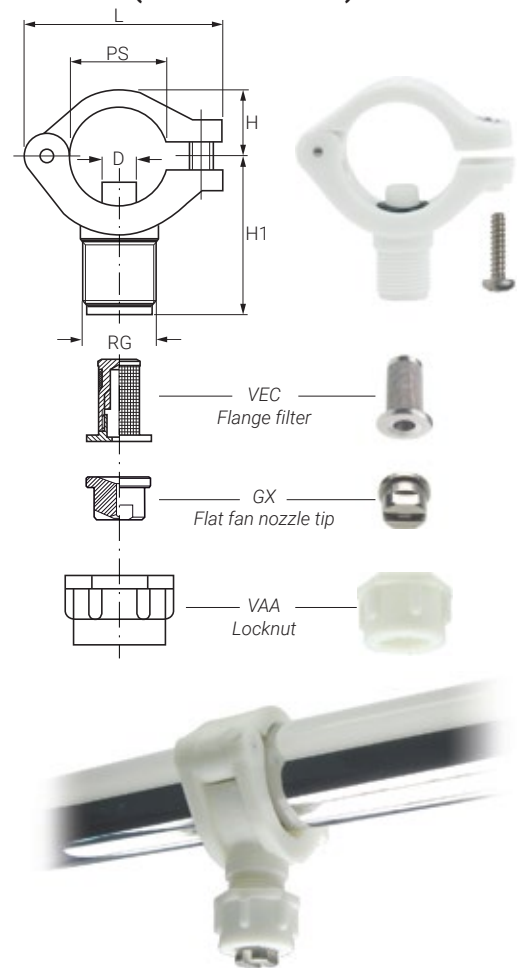

HOW TO MAKE UP THE PRODUCT CODE Ex.: ZPB 0050 D6

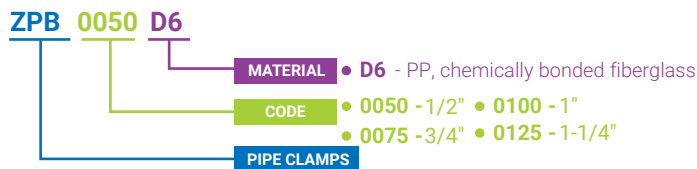

( PLASTIC BAYONET PIPE CLAMPS ) **ZPC**

PLASTIC BAYONET PIPE CLAMPS

ZPC plastic bayonet pipe clamps serve for a quick and easy instalment of GX type flat fan flanged nozzles. No need to weld nozzles or use thick pipes to thread. It's sufficient to make a hole in the pipe and fix the clamp in. The clamp body is in PVDF while screws and bolts are in stainless steel AISI 316, suitable for high temperatures. Their quick-fit cap is easy to disassemble for cleaning. The flat fan orientation has an offset angle of 10° from the main manifold axis to avoid jets overlapping.

TYPICAL APPLICATIONS	PCB wet process Pre-treatment for coating process
PIPE SIZE	PS 1/2"
MAX WORKING TEMPERATURE	LT 90°C
MAX WORKING PRESSURE	LP 8 bar
MATERIAL	Body <b>D82</b> PVDF, moulded O-ring <b>E7</b> Viton Metal parts <b>B3</b> AISI 316 Stainless Steel

CODE	PS inch	PD mm	D mm	H mm	H1 mm	L mm	W g
ZPC 0500 D82P	1/2"	20/22	6.0	14.5	54.0	44.0	45.0

HOW TO MAKE UP THE PRODUCT CODE Ex.: ZPC 0500 D82P

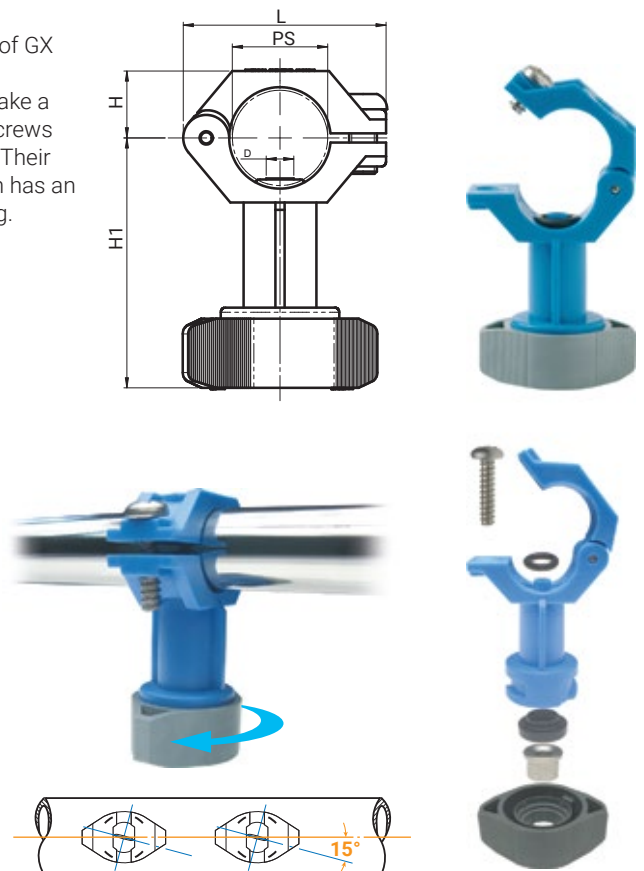
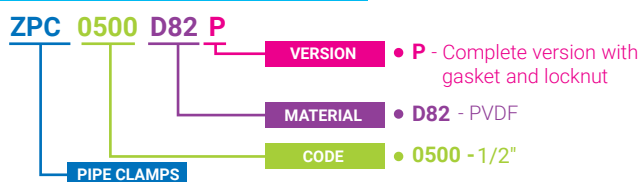

# ZPM (METAL PIPE CLAMPS)

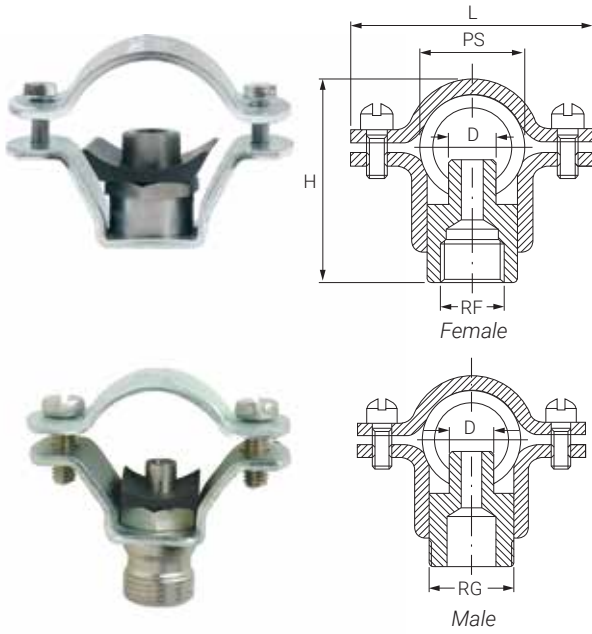

## METAL PIPE CLAMPS

ZPM metal pipe clamps are suitable for a quick, easy and safe installation of various types of nozzles on pipes. They can be fit into a pipe simply by making a hole on it. As it's not necessary to thread thick pipes or weld the nozzles, these clamps assure a relevant time and costs saving.

THREAD SIZE	1/8", 1/4", 3/8", 1/2"
CONNECTION	BSP, NPT
TYPICAL APPLICATIONS	Pre-treatment for coating process Exhaust Scrubber
PIPE SIZE	PS 1/2", 3/4", 1", 1 1/4", 1 1/2", 2", 2 1/2"
MAX WORKING TEMPERATURE	LT 80 °C
MAX WORKING PRESSURE	LP 20 bar
MATERIAL	Body Screws Nipples Gasket
	<b>B2</b> AISI 304 Stainless Steel <b>A8</b> Zinc coated steel <b>B2</b> AISI 304 Stainless Steel <b>B31</b> AISI 316L Stainless Steel <b>T1</b> Brass <b>E0</b> EPDM



ZPM Metal clamps  
+  
PF Hollow cone nozzle

CODE	PS inch	RF/RG inch	LP bar	LQ l/min	D mm	H mm	L mm
ZPM 0050 xxAW	1/2"	1/8"	17	11	7	40	49
ZPM 0050 xxBW		1/4"				48	
ZPM 0050 xxUW		3/8"				48	
ZPM 0075 xxAW	3/4"	1/8"	17	11	7	45	58
ZPM 0075 xxBW		1/4"				48	
ZPM 0075 xxUW		3/8"				53	
ZPM 0100 xxAW	1"	1/8"	17	11	7	45	65
ZPM 0100 xxBW		1/4"				48	
ZPM 0100 xxUW		3/8"				53	
ZPM 0125 xxYW	1 1/4"	1/4"	9	45	18	68	71
ZPM 0125 xxYW		3/8"				68	
ZPM 0125 xxYW		1/2"				71	
ZPM 0150 xxYW	1 1/2"	1/4"	9	45	18	72	90
ZPM 0150 xxYW		3/8"				72	
ZPM 0150 xxYW		1/2"				90	
ZPM 0200 xxYW	2"	1/4"	9	45	18	85	100
ZPM 0200 xxYW		3/8"				85	
ZPM 0200 xxYW		1/2"				100	
ZPM 0250 xxYW	2 1/2"	1/4"	9	45	18	110	118
ZPM 0250 xxYW		3/8"				110	
ZPM 0250 xxYW		1/2"				118	

### CODE COMPLEMENTS

Ex.: ZPM 0050 A8 AA

Replace xx and YW in the above codes as shown below

NOTE: Nipple thread (letter Y) can be 3/8" BSP F (letter C) or 1/2" BSP F (letter D) only for pipe sizes (PS in the above table) equal or greater than 1-1/2".

### ZPM 0050 xx Y W

XX	FOR CLAMP MATERIAL	Y	FOR NIPPLE THREAD	W	FOR NIPPLE MATERIAL
A8	Zinc coated steel	A	1/8" BSP Female	A	Brass
B2	AISI 304	B	1/4" BSP Female	B	AISI 303
		C	3/8" BSP Female	C	AISI 316L
		D	1/2" BSP Female		
		U	3/8" BSP Male		

## ( DISK NOZZLE PIPE CLAMP ) ZPH

### DISK NOZZLE PIPE CLAMP

ZPH pipe clamps are specially designed for the quick and easy instalment of disc nozzles onto pipes. These clamps are very convenient as there's no need to buy expensive metal tips or welded nozzle tips.

You must drill a 19 mm diameter hole on the pipe, insert the clamp into it and fix it with screws. Their design, which allows to position the disc nozzles with a 5° offset angle, assures a proper jet orientation. These clamps avoid spray jets interference and are ideal for nozzles cleaning steel brushes.

MAX WORKING TEMPERATURE	LT	90°C		
MAX WORKING PRESSURE	LP	7 bar		
FITTING DIMENSIONS	Outer pipe diameter	50 mm		
	Inner pipe diameter	47 mm		
	Feed hole	19 mm		
MATERIAL	Fascetta	<b>D6</b>	PP, chemically bonded fiberglass	
	Perno, vite	<b>B3</b>	AISI 316 Stainless Steel	
TYPICAL APPLICATION			Paper machines self-cleaning pipes	

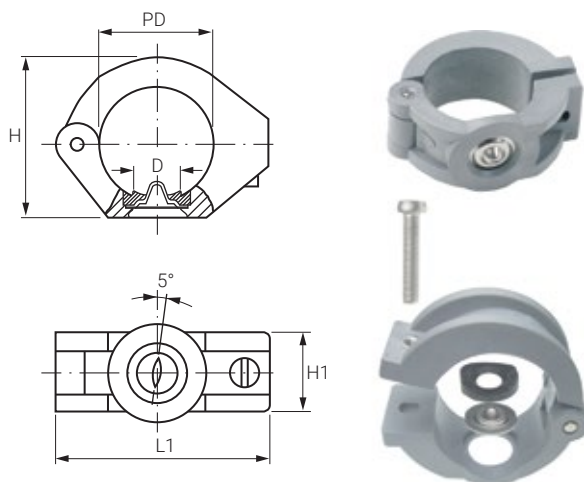

CODE	PD mm	D mm	H mm	H1 mm	L1 mm
ZPH 0150 D6	52	19	70	34	91

HOW TO MAKE UP THE PRODUCT CODE Ex.: ZPH 0150 D6



## ( LOCKNUTS ) VAA

### LOCKNUTS

VAA locknuts in steel or brass are mounted on all ZAA, ZAC, ZLA and ZPB nipples to fix various types of nozzles. The VAA 0380 D6B locknut, on the other hand, is used with the ZPB clamp.

CODE	RF inch	D mm	H mm	WS mm	Material	
					Plastic	Metal
VAA 0380 xxB	3/8"	12.9	12	22	•	•
VAA 0381 xxB	3/8"	12.5	15	22		•
VAA 0750 xxB	3/4"	20.5	16	32		•
VAA 1250 xxB	1 1/4"	32.5	27	50		•

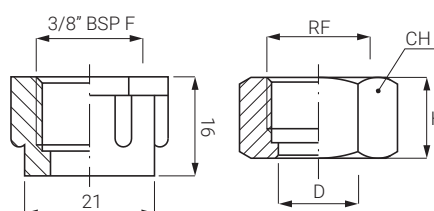

VAA 0380 D6B

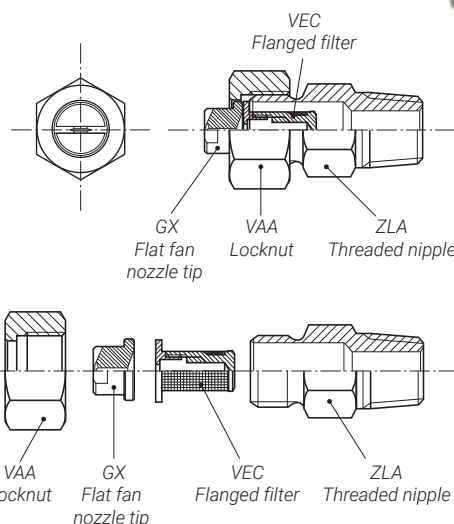

HOW TO MAKE UP THE PRODUCT CODE Ex.: VAA 0380 B1B



# ZAA / ZAB ( STANDARD WELDING NIPPLES )

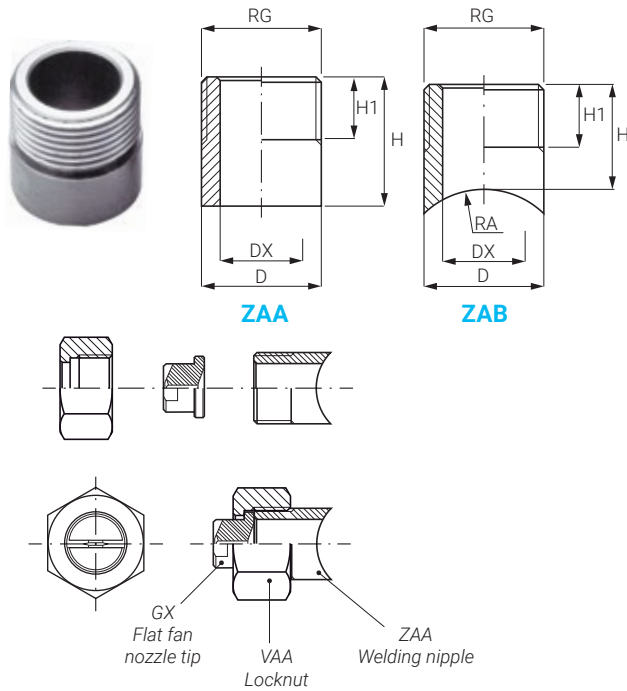

## STANDARD WELDING NIPPLES

ZAA/ZAB welding nipples allow the assembly of GX, BX or KX series nozzle tips onto pipes and spray manifolds. One end of the nipple is fixed onto the pipe and the other to the nozzle tip. ZAA is a standard model with a flat welding surface. ZAB is radiused type with a curved welding surface that fits the pipe diameter. VAA locknut goes with ZAA/ZAB weld nozzle tip. Additionally, we suggest you to add VEA, VEC or VED flanged filters to avoid clogging when you use small orifice nozzles.

THREAD SIZE 3/8", 3/4"  
 MATERIAL **B1** AISI 303 Stainless Steel **D1** PP  
**B31** AISI 316L Stainless Steel **D8** PVDF

CODE	RG inch	H mm	H1 mm	D mm	DX mm	RA mm	W g
STANDARD							
<b>ZAA C018 xxG</b>	3/8"	18	10	17	11.5	-	20
<b>ZAA E027 xxG</b>	3/4"	27	15	27	18.0	-	61

CODE	RG inch	H mm	H1 mm	D mm	DX mm	RA mm	W g
RADIUSED							
<b>ZAB C018 xxD</b>	3/8"	18	10	17	11.5	10.0	20
<b>ZAB C018 xxE</b>						12.5	
<b>ZAB C018 xxF</b>						16.0	
<b>ZAB C018 xxG</b>						20.0	
<b>ZAB C018 xxH</b>						25.0	

PNR Italia is available to supply additional models with measures on request.

# ZAC ( DOVE-TAIL WELDING NIPPLES )

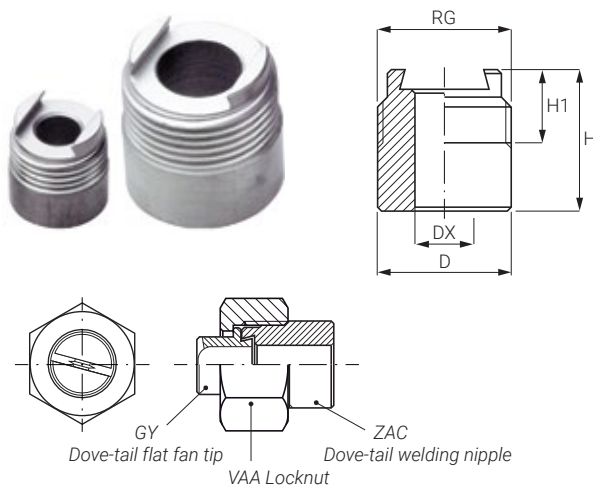

## DOVE-TAIL WELDING NIPPLES

ZAC welding nipples are manufactured with a dovetail end to match GY type dove-tail nozzle tips. One end of the nipple is fastened onto the pipe and the other end to the nozzle tip by means of a VAA locknut. The dove-tail design of these nipples keeps them properly orientated in the desired position, thus shortening time for nozzle tips cleaning and orientation adjustments.

THREAD SIZE 3/8", 3/4", 1 1/4"  
 MATERIAL **B1** AISI 303 Stainless Steel **D2** PP  
**B31** AISI 316L Stainless Steel **D8** PVDF

CODE	RG inch	H mm	H1 mm	D mm	DX mm	W g
<b>ZAC C018 xx</b>	3/8"	18.0	10.0	17	7.5	20
<b>ZAC E027 xx</b>	3/4"	27.5	14.0	27	14.0	61
<b>ZAC G040 xx</b>	1 1/4"	40.0	21.0	42	20.0	280

# ZLA / ZLC ( STANDARD THREADED NIPPLES )

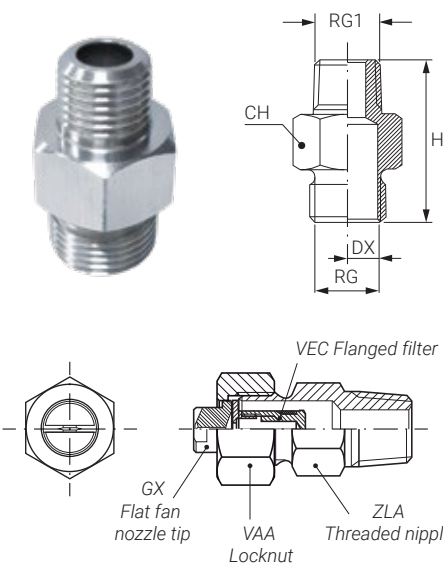

## STANDARD THREADED NIPPLES

ZLA threaded nipples have a flanged end to match nozzle tips type GX, BX or KX. One end of the nipple gets assembled onto the pipe and the other end to the nozzle tip to which it is fixed by means of a VAA locknut. In addition, flanged filters VEA, VEC and VED can be assembled to avoid clogging.

INLET THREAD SIZE 1/8", 1/4", 3/8", 1/2", 3/4"  
 OUTLET THREAD SIZE 1/8", 1/4", 3/8", 1/2", 3/4"  
 CONNECTION RG1: BSPT (A), BSP (C) RG: BSP  
 MATERIAL **B1** AISI 303 Stainless Steel **T1** Brass **D2** PP  
**B31** AISI 316L Stainless Steel **D1** PVC **D8** PVDF

CODE	RG inch	RG1 poll	DX mm	H mm	CH mm	W g	RG1					
							RG	1/8"	1/4"	3/8"	1/2"	3/4"
<b>ZLx 1212 xxB</b>	1/8"	1/8"	5.00	25.0	14	18	1/8"	•	•	•	•	•
<b>ZLx 2525 xxB</b>	1/4"	1/4"	7.50	29.0	19	20	1/4"		•	•	•	•
<b>ZLx 3838 xxB</b>	3/8"	3/8"	10.0	35.0	19	25	3/8"	•	•	•	•	•
<b>ZLx 5050 xxB</b>	1/2"	1/2"	15.0	38.0	27	50	1/2"			•	•	•
<b>ZLx 7575 xxB</b>	3/4"	3/4"	18.0	40.0	32	90	3/4"				•	•

The table on the right shows the different combinations PNR Italia can produce, based on the inlet thread size RG1 and the outlet thread size RG. Our Technical Office is at your disposal to give you codes and dimensions.

( PRESSURE TANKS ) **UMR**

PRESSURE TANKS



UMR pressure tanks are widely used to spray liquids under pressure containing disinfectants and so on. They are an excellent choice as they make it possible to deliver liquids to air atomizers without requiring expensive pumps and can also be operated as mobile units.

INLET / OUTLET DIAMETER	Quick connection or 1/4" PT (Female)
MAX WORKING PRESSURE	LP 4,9 bar
MATERIAL	Body <b>B2</b> AISI 304 Stainless Steel
	Base & Handles <b>E8</b> Synthetic rubber (NBR)
	Quick connection <b>E31</b> Delrin®
	O-Ring <b>E0</b> EPDM

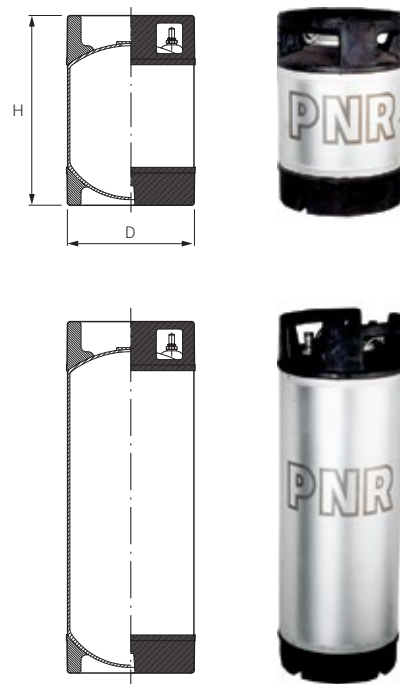
CODE COVER ONLY	COVER AND NIPPLES	CA liters	D mm	H mm	W kg	LP bar
UMR 0090 B2	UMR C090 B2	9	232	340	3,65	4,9
UMR 0190 B2	UMR C190 B2	19	219	630	4,00	4,9



**PRESSURE TANKS - ACCESSORIES**

<b>XUM R110 E31</b>	LIQUID CONNECTION KIT Connection: 7/16-20UNF	
<b>XUM R100 E31</b>	AIR CONNECTION KIT Connection: 7/16-20UNF	

Please note that both connection kit, air and liquid, can only be supplied as a complete assembly, it is not possible to supply single components.

PRESSURE TANK OPERATION

Remove the pressure tank cover, fill in the liquid and put the cover back on. Fill the tank with compressed air. The liquid is pushed out (see picture above) by the pressure inside the tank which is higher than the outside pressure. Generally, we recommend to add a gas pressure regulator and a pressure gauge on the pressure tank inlet and outlet to adjust inside and outside pressures.





# VEA (HAT FILTERS)

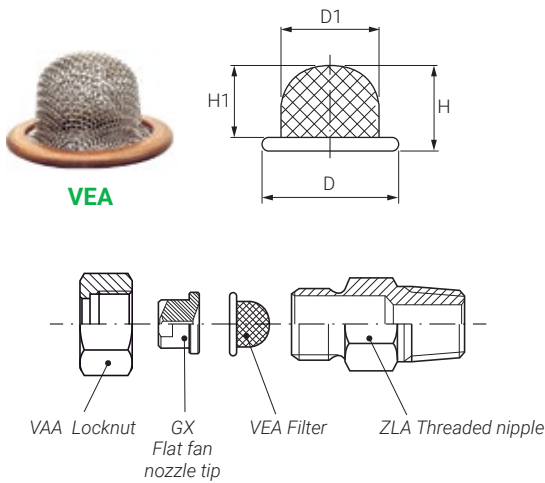

## HAT FILTERS

VEA series hat-shaped check-valve filters are specially designed for 3/8" flanged nozzles. They are drip-free and protect the nozzle tips. We recommend to assemble filters with check-valve on small capacity nozzles to avoid clogging and enhance their performance.

MESH NUMBER 50, 75, 100 mesh  
 MATERIAL Collar **T33** Copper + AISI 316  
 Wire net **B3** AISI 316 Stainless Steel  
**Typical application** Filtering before spraying liquids

CODE	D mm	D1 mm	H mm	H1 mm	M mesh	Nozzle code
<b>VEA 0138 T9</b>	14.5	9.5	8.5	7.3	100	GX BX
<b>VEA 0238 T9</b>					75	FX
<b>VEA 0338 T9</b>					50	KX

# VEC (FLANGED FILTERS)

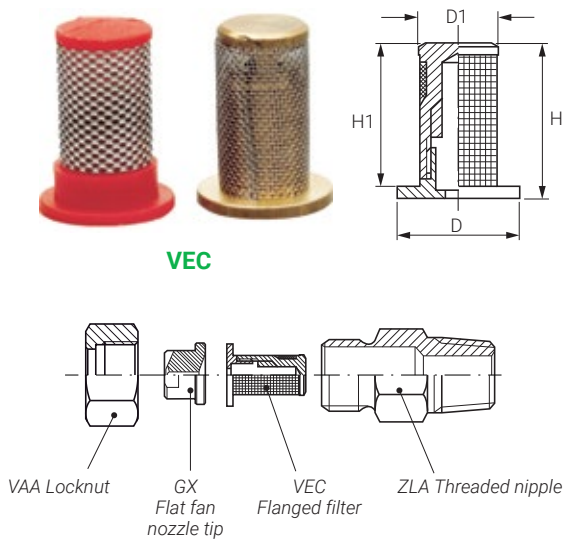

## FLANGED FILTERS

VEC check-valve filters are specially designed for 3/8" flanged nozzles. They are drip-free and protect the nozzle tips. We recommend to assemble these filters on small capacity nozzles to avoid clogging and enhance their performance.

MATERIAL Body **B1** AISI 303 Stainless Steel  
**B31** AISI 316L Stainless Steel  
**D3** Nylon  
**T1** Brass  
 Wired net **B2** AISI 304 Stainless Steel  
**TYPICAL APPLICATION** Filtering before spraying liquids

CODE	D mm	D1 mm	H mm	H1 mm	M mesh	Nozzle code
<b>VEC 0138 xx</b>	15.0	10.0	20.0	18.5	100	GX BX
<b>VEC 0238 xx</b>					75	FX
<b>VEC 0338 xx</b>					50	KX

# VEF (THREADED FILTERS)

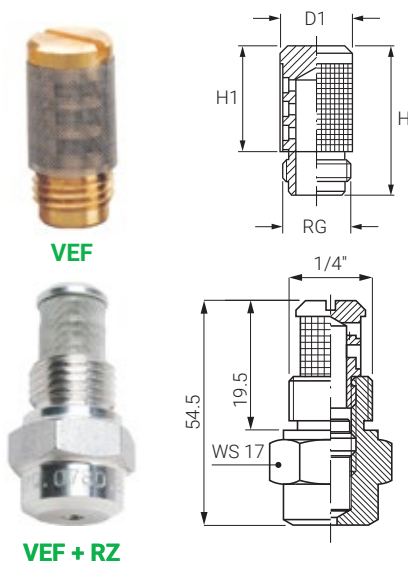

## THREADED FILTERS

VEF threaded filters are specially designed for 1/4" J series flat fan nozzles and RX/RZ hollow cone nozzles. They provide a top filtering action and protect nozzle tips. We recommend to assemble threaded filters on small capacity nozzles to avoid clogging and enhance their performance.

THREAD SIZE 3/8" UNF, M7, M8  
 MESH NUMBER 50, 75, 100 mesh  
 MATERIAL Body **B1** AISI 303 Stainless Steel  
**B31** AISI 316L Stainless Steel  
**T1** Brass  
 Wired net **B2** AISI 304 Stainless Steel  
**TYPICAL APPLICATION** Filtering before spraying liquids

CODE	D1 mm	RG inch	H mm	H1 mm	M mesh	Nozzle code
<b>VEF 0112 xx</b>	10.0	M8	16.0	12.0	100	RX, RZ
<b>VEF 0138 xx</b>	10.2	3/8"UNF	21.0	15.0	100	JB(1/4")
<b>VEF 0238 xx</b>					75	
<b>VEF 0338 xx</b>					50	
<b>VEF 0411 xx</b>	8.1	M7	15.7	13.2	120	JA(1/8")

# ( CHECK-VALVE FILTERS ) VED

## CHECK-VALVE FILTERS

VED series check-valve filters are specially designed for 3/8" flanged nozzles. VED filters contain a one-way ball valve to avoid dripping when spray is turned off. They also serve to protect the nozzle tips. We recommend to assemble check-valve filters on small capacity nozzles to avoid clogging and enhance their performance.

OPENING PRESSURE	0.35, 0.70, 1.40, 2.00, 2.80 bar
WIRE NET MESH SIZE	50, 80, 100 mesh
MATERIAL	Body
	<b>B1</b> AISI 303 Stainless Steel
	<b>B31</b> AISI 316L Stainless Steel
	<b>D3</b> Nylon
	<b>T1</b> Brass
	Wire net
	<b>B2</b> AISI 304 Stainless Steel

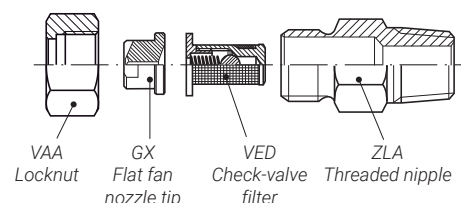
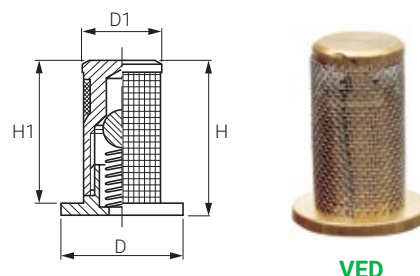

Table for body material: AISI 303, AISI 316L, brass

CODE	D mm	D1 mm	H mm	H1 mm	M mesh	Opening bar
VED 0138 xxA	15.0	10.0	20.0	18.5	100	0.35
VED 0238 xxA	15.0	10.0	20.0	18.5	80	0.35
VED 0338 xxA	15.0	10.0	20.0	18.5	50	0.35
VED 0138 xxB	15.0	10.0	20.0	18.5	100	0.70
VED 0238 xxB	15.0	10.0	20.0	18.5	80	0.70
VED 0338 xxB	15.0	10.0	20.0	18.5	50	0.70
VED 0138 xxC	15.0	10.0	20.0	18.5	100	1.40
VED 0238 xxC	15.0	10.0	20.0	18.5	80	1.40
VED 0338 xxC	15.0	10.0	20.0	18.5	50	1.40
VED 0138 xxD	15.0	10.0	20.0	18.5	100	2.80
VED 0238 xxD	15.0	10.0	20.0	18.5	80	2.80
VED 0338 xxD	15.0	10.0	20.0	18.5	50	2.80

## CARTRIDGE SIZE TABLE

To figure out mesh sizes one has to count the number of openings from the centre of any one wire to the centre of a parallel wire one inch away. The number of openings in a filter cartridge is the mesh size. We highly recommend to add filters to small capacity nozzles to hold fine particulate matter.

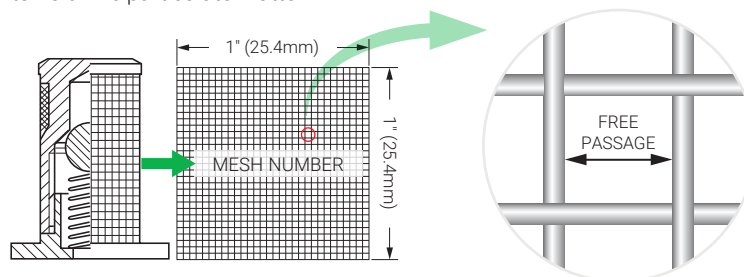

Table for body material: nylon

CODE	D mm	D1 mm	H mm	H1 mm	M mesh	Opening bar
VED 0138 xxB	15.0	10.0	20.0	18.5	100	0.70
VED 0238 xxB	15.0	10.0	20.0	18.5	80	0.70
VED 0338 xxB	15.0	10.0	20.0	18.5	50	0.70
VED 0138 xxE	15.0	10.0	20.0	18.5	100	2.00
VED 0338 xxE	15.0	10.0	20.0	18.5	50	2.00





## HOW TO CHOSE THE PROPER FILTER?

The largest filter free passage < nozzle orifice

MESH NUMBER	Free passage mm
30 - 32	0.6 - 0.58
50	0.30
60	0.25
75	0.20
80	0.18
100	0.15
150	0.10
200	0.075

If the nozzle tip diameter is 0.3 mm, we suggest you to choose a 60 mesh filter or more (free passage 0.25 mm). Please consider that the higher is the number of mesh, the greater is the filtering power.

We offer a large assortment of VE series filters for your convenience.

CODE	VEC	VED	VEF	VEA
<b>Appearance</b>				
	Flanged	Check-valve	Threaded	Hat
<b>B1</b> AISI 303	•	•	•	
<b>B31</b> AISI 316L	•	•	•	
<b>D3</b> Nylon	•	•	•	
<b>T1</b> Brass	•	•	•	
<b>T9</b> Copper				•

## HOW TO MAKE UP THE FILTER CODE

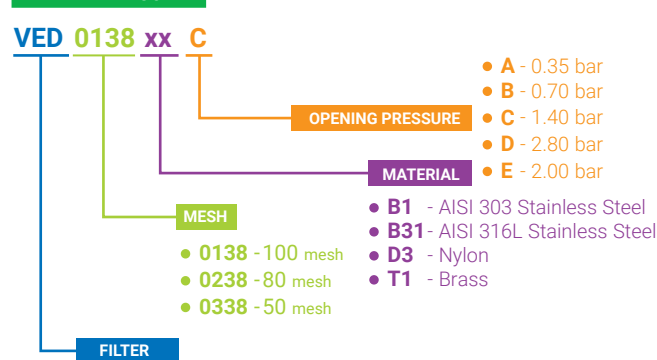

# VEH ( PLASTIC BODY FILTERS )

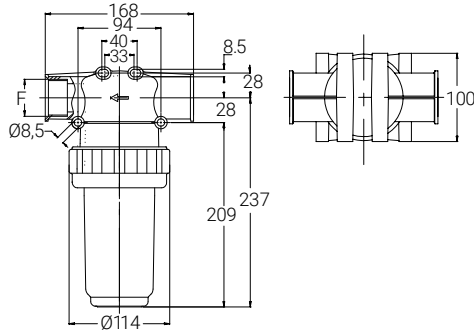

## PLASTIC BODY FILTERS

VEH filters with plastic body are a rational and economic solution for most operating environments. The threaded coupling between bowl and head allows a quick filter cleaning and easy replacement of the cartridge and no need of tools. They have a high particles retention and are durable.

INLET/OUTLET THREAD SIZE 1/2", 3/4", 1", 1 1/4", 1 1/2"  
 MAX STEAM PRESSURE LP from 10 bar to 15 bar  
 CAPACITY LQ 280 l/min  
 MATERIAL Body **D6** Polypropylene + 30% Glass fiber  
 Seal **E0** EPDM  
 Cartridge **B2** AISI 304 Stainless Steel  
 TYPICAL APPLICATION Filtering before spraying liquids

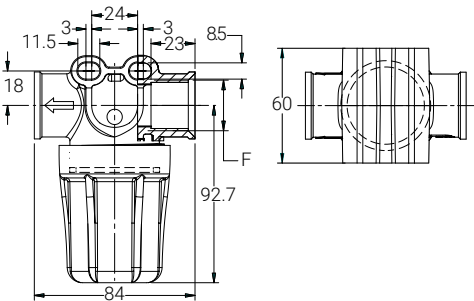

CODICE	RF poll. BSPP	H mm	H1 mm	L mm	Q l/min	Cartuccia	M mesh
8105037 VEH 0051 D25*	1/2"	110,7	92,7	84	55		50
8105039 VEH 0052 D25*							100
8105000 VEH 0050 D21	1/2"	126,0	108	127	80	XVE H450 D21T	32
8105001 VEH 0051 D21						XVE H451 D21T	50
8105003 VEH 0052 D21						XVE H452 D21T	100
8105024 VEH 0075 D21	3/4"	126,0	108	127	100	XVE H450 D21T	32
8105025 VEH 0076 D21						XVE H451 D21T	50
8105027 VEH 0077 D21						XVE H452 D21T	100
8121000 VEH 0125 D21	1 1/4"	265,0	237	168	200	XVE HA60 DA2	32
8121001 VEH 0126 D21						XVE HA61 DA2	50
8121003 VEH 0127 D21						XVE HA62 DA2	100
8121004 VEH 0150 D21	1 1/2"	265,0	237	168	280	XVE HA60 DA2	32
8121005 VEH 0151 D21						XVE HA61 DA2	50
8121007 VEH 0152 D21						XVE HA62 DA2	100

### HOW TO MAKE UP THE FILTER CODE

EX.: VEH 0050 D21

### VEH 0050 D21



# VEL ( BRASS BODY FILTERS )

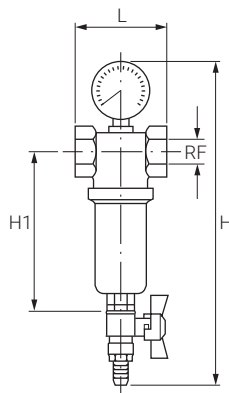

## BRASS BODY FILTERS

VEL type filters with body in brass are the ideal solution for small plants requiring easy cleaning and maintenance. When necessary, simply open the valve at the bottom of the filter and the dirt contained inside the cartridge is easily expelled. A manometer on the filter head shows the outlet pressure hence pressure drop when clogged.

INLET/OUTLET THREAD SIZE 1/2", 3/4", 1", 1 1/4", 1 1/2", 2"  
 MAX OPERATION TEMPERATURE LT 100°C  
 MAX STEAM PRESSURE LP 16 bar  
 MATERIAL BODY **T8** Nickel plated brass  
 CARTRIDGE **B2** AISI 304 Stainless Steel  
 TYPICAL APPLICATION Filtering before spraying liquids

### HOW TO MAKE UP THE FILTER CODE

EX.: VEL 0039 T8

### VEL 0039 T8

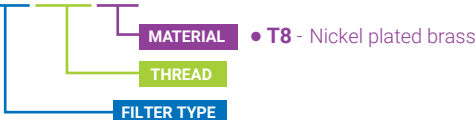

CODE	RF inch BSPP	H mm	H1 mm	L mm	Q l/min	Cartridge	M mesh
VEL 0039 T8	3/8"	285	133	50	14	XVE L171 B2	150
VEL 0051 T8	1/2"	288	136	56	25		
VEL 0076 T8	3/4"	287	132	67	38	XVE L172 B2	
VEL 0101 T8	1"	295	137	80	72		
VEL 0126 T8	1 1/4"	343	169	92	118	XVE L200 B2	
VEL 0151 T8	1 1/2"	356	179	110	178	XVE L201 B2	
VEL 0201 T8	2"	362	179	110	213		

( LARGE CAPACITY FILTERS ) **VEM**

LARGE CAPACITY FILTERS

VEM filters are specially designed for high particle retention, easy maintenance and great efficiency in harsh operating conditions. Their bowl houses a large size cartridge for a longer operating life and reduced servicing times. The threaded connection to the filter body allows a quick removal with no need of tools. A plug placed at the bottom of the bowl allows to fit in a ball valve to purge the filter.

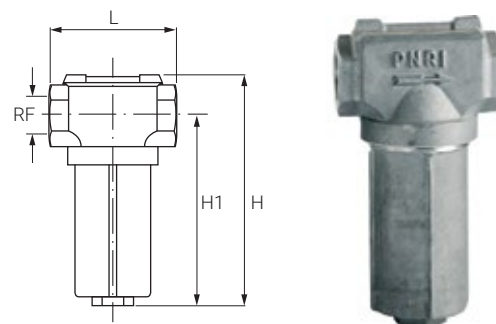

THREAD SIZE 1/2", 3/4", 1", 1 1/4", 1 1/2", 2", 2 1/2", 3"  
 WIRE NET MESH SIZE 60, 80 mesh  
 MAX WORKING PRESSURE LP 40 bar  
 MATERIAL Body & bowl **V1** Aluminium casting  
 Cartridge **B2** AISI 304 Stainless Steel  
 TYPICAL APPLICATION Filtering before spraying liquids

MESH NUMERO	Free passage mm
30 - 32	0.6 - 0.58
50	0.3
60	0.25
75	0.2
80	0.18
100	0.15
150	0.1
200	0.075

CODE	RF inch BSP	H mm	H1 mm	L mm	LP bar	Q l/min	Cartridge	M mesh	kg
VEM 0050 V1	1/2"	210	152	105	40	70	XVE M075 B2	60	0.9
VEM 0051 V1							XVE M076 B2	80	
VEM 0075 V1	3/4"	210	152	105	40	95	XVE M075 B2	60	
VEM 0076 V1							XVE M076 B2	80	
VEM 0100 V1	1"	210	152	105	40	140	XVE M075 B2	60	
VEM 0101 V1							XVE M076 B2	80	
VEM 0125 V1	1 1/4"	270	210	140	30	280	XVE M150 B2	60	1.6
VEM 0126 V1							XVE M151 B2	80	
VEM 0150 V1	1 1/2"	270	210	140	30	315	XVE M150 B2	60	
VEM 0151 V1							XVE M151 B2	80	
VEM 0200 V1	2"	400	318	200	10	750	XVE M300 B2	30	5.6
VEM 0201 V1							XVE M301 B2	60	
VEM 0202 V1							XVE M302 B2	80	
VEM 0250 V1	2 1/2"	400	318	200	10	810	XVE M300 B2	30	
VEM 0251 V1							XVE M301 B2	60	
VEM 0252 V1							XVE M302 B2	80	
VEM 0300 V1	3"	400	318	200	10	1050	XVE M300 B2	30	
VEM 0301 V1							XVE M301 B2	60	
VEM 0302 V1							XVE M302 B2	80	

HOW TO MAKE UP THE FILTER CODE

EX.: VEM 0050 V1

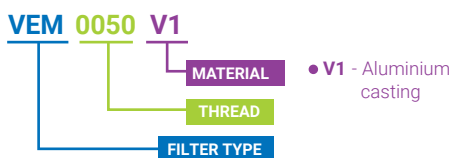

"Y" STYLE FILTER

VEQ xxGF B3G filter is widely used in all types of nozzles filtering systems. It allows for quick cleaning and replacement with no need of tools.

INLET/OUTLET THREAD SIZE 1/2", 3/4", 1"  
 MESH 60 Mesh  
 MAX OPERATION TEMPERATURE LT 40°C  
 MAX OPERATION PRESSURE LP 10 bar  
 MAX CAPACITY LQ 80 l/min  
 MATERIALI Body **D6** PP, chemically bonded fiberglass  
 Cartridge **B3** AISI 304 Stainless Steel  
 TYPICAL APPLICATION Filtering before spraying liquids

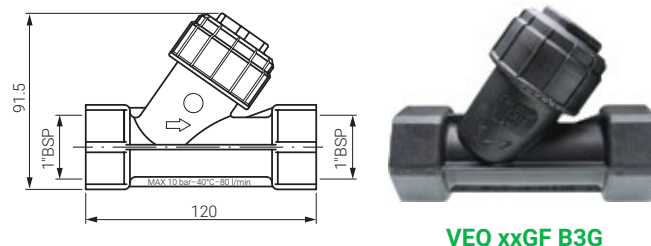

( "Y" STYLE FILTER ) **VEQ**

# UMW ( HIGH PRESSURE GUNS )

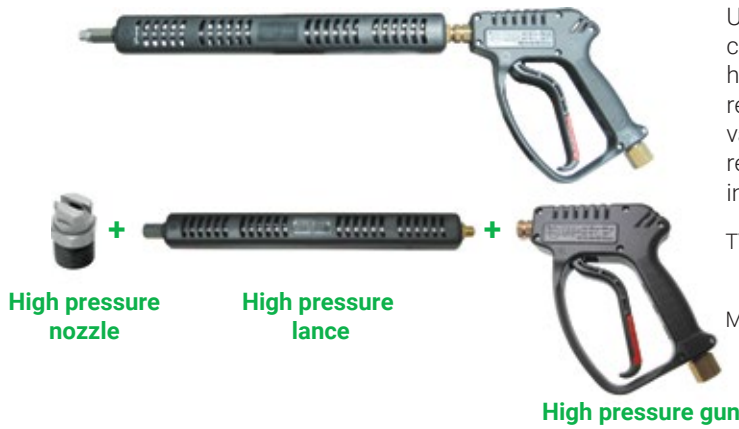

## UMW SERIES HIGH PRESSURE GUNS

UMW series spray guns are specially designed for high pressure cleaning. The main features are: light weight and easy to handle, heavy duty durability, high temperatures and high pressures resistant, low failure rate, low price. They can be supplied with a variety of pressure hoses and nozzles for all types of cleaning requirements. UMW spray guns are widely and successfully used in car washing and many other industrial applications.

### TYPICAL APPLICATIONS

Products cleaning  
Equipment cleaning  
Vehicles cleaning

### MATERIAL

Body  
Inside parts

**D4** Nylon, Glassfibers reinforced  
**B1** AISI 303 Stainless Steel  
**C3** AISI 440 Stainless Steel, hardened  
**T1** Brass

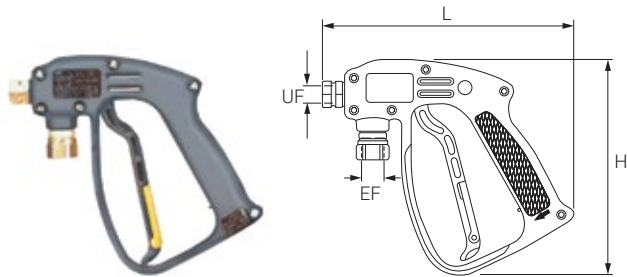

UMW 0010 D4

**UMW 0010 D4** series economical and efficient spray guns are widely applied in industrial high pressure cleaning and car wash.

NOMINAL PRESSURE 200 bar  
MAX OPERATION PRESSURE LP 220 bar  
MAX OPERATION TEMPERATURE LT 160 °C  
MAX CAPACITY LQ 30 l/min

CODE	Inlet thread size EF	Outlet thread size UF	H mm	L mm	W kg
UMW 0010 D4	3/8"	1/4"	162	185	0.27

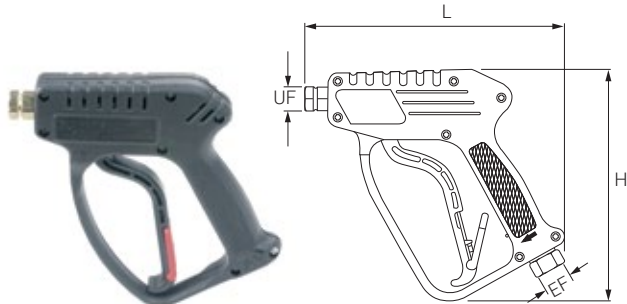

UMW 0020 D4

**UMW 0020 D4** guns are suitable for heavy duty applications. They are light and have an ergonomical easy-grip handle. These spray guns are highly appreciated for operations requiring high pressure and

NOMINAL PRESSURE 310 bar  
MAX OPERATION PRESSURE LP 350 bar  
MAX OPERATION TEMPERATURE LT 160 °C  
MAX CAPACITY LQ 40 l/min

CODE	Inlet thread size EF	Outlet thread size UF	H mm	L mm	W kg
UMW 0020 D4	3/8"	1/4"	183	202	0.78

## HIGH PRESSURE GUNS

Code	UMW 0020 D4 (Brass) Standard high pressure gun	UMW 0021 D4 (Brass) Swivel high pressure gun	UMW 0020 B1 (Stainless Steel) Sanitary high pressure gun
Appearance			
Code	UMW 0020 D4	UMW 0021 D4	UMW 0020 B1
Inlet thread size	3/8" BSP Female	3/8" BSP Female	3/8" BSP Female
Outlet thread size	1/4" BSP Female	1/4" BSP Female	1/4" BSP Female
Max operating pressure	350 bar	280 bar	280 bar
Max operating temperature	160°C	160°C	160°C
Max capacity	40 l/min	40 l/min	40 l/min
Inner parts	Brass	Brass	AISI 303
Outside shell	PP, chemically bonded fiberglass	PP, chemically bonded fiberglass	PP, chemically bonded fiberglass
Weight	0.78 kg	0.78 kg	0.83 kg
Swivel	✗	✓	✗
Security lock	✓	✓	✓



( HIGH PRESSURE GUNS )



HIGH PRESSURE LANCE			
Appearance			
Code	<b>UMW 0038 A8</b>	<b>UMW 0045 B2</b>	<b>UMW 0047 B2</b>
Liquid inlet diameter	1/4" BSPT Male	1/4" BSPT Male	1/4" BSPT Male
Liquid outlet diameter	1/4" BSP Female	1/4" BSP Female	1/4" BSP Female
Max operating pressure	280 bar	280 bar	200 bar
Max operating temperature	160°C	160°C	160°C
Spray lance	Zinc coated steel	AISI 304	AISI 304
Shank	Brass	AISI 303	AISI 303
Plastic material	PP, chemically bonded fiberglass	PP, chemically bonded fiberglass	PP, chemically bonded fiberglass
Length	380 mm	1200 mm, 1500 mm 1700 mm, 2000 mm	700 mm
Weight	0.4 kg	0.9 kg, 1.1 kg, 1.3 kg, 1.4 kg	0.56 kg

HIGH PRESSURE NOZZLES			
Appearance			
Code	<b>F series high pressure nozzles</b>	<b>UMW 0050 B2</b>	<b>UMW 0060 D2</b>
Spray pattern	Straight / Flat fan (Fixed)	Straight / Flat fan (Free)	High pressure water (360°)
Spray angle	0°, 15°, 25°, 40°, 65°	0° ~ 40°	40°
Capacity	3.4 ~ 68.2 l/min a 100 bar	10.3 l/min a 100 bar	6.86 ~ 18.1 l/min a 100 bar
Thread size	1/4" BSP Male	1/4" BSP Female	1/4" BSP Female
Min operating pressure	--	--	80 bar
Max operating pressure	500 bar	280 bar	250 bar
Max operating temperature	600°C	90°C	100°C
Nozzle material	AISI 416	AISI 420	AISI 420
Shank	--	Brass	Brass
Plastic material	--	PP, chemically bonded fiberglass	PP, chemically bonded fiberglass

# UMV (HOT WATER SPRAY GUN)

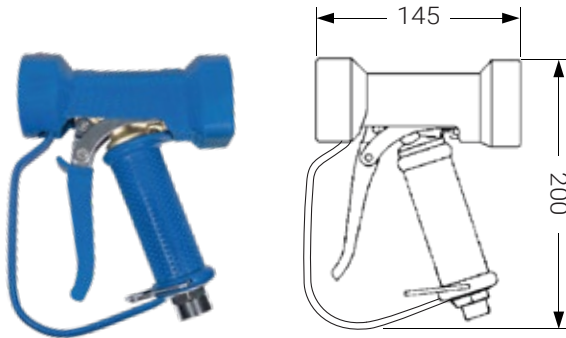

UMV 2210 xx

The versatility of this washgun is enhanced from the additional model **UMV 2211 xx**, which can be fitted with nozzles or different lances through its 1/2" male thread. The three different lance models shown are easily fitted to the gun body with a 1/2" male nipple and offer the following choices of operation:

1. Foaming machines and equipment prior to washing operations. The foam lance comes with a quick connect female coupling, and a matching coupling must be fitted at the gun outlet.
2. General purpose 1/4" female thread outlet, 1/4" male thread inlet. Available both with heat protection sleeve, or zincplated steel. The general purpose lance needs a connection nipple 1/4" fem to 1/2" female to be fitted on the gun.

## HOT WATER WASHING GUN

The UMV series washgun has been designed primarily to avoid hot water waste, while assuring very comfortable operation conditions. Its thick rubber casing not only effectively protects the operator's hand from the discomfort of hot water but also assures an excellent protection in case the washgun is dropped or falls to the ground since it avoids any damage to the tiles or the equipment. The careful design, mainly used for the food industry, also includes a grease and detergent resistant quality rubber, plus a blue colour has been chosen as a visual aid to be seen clearly against a white or clear foreground. The trigger is lined too, and can be held in the open position by means of a lock-ring. The spray pattern can be adjusted continuously between a closed straight jet to a wide angle spray, so that the proper spray pattern can be chosen for each individual job.

### MATERIALI

Body	<b>T2</b> Brass casting, chrome plated
	<b>B31</b> AISI 316L Stainless Steel
Lining	<b>E0</b> EPDM
Steam	<b>B3</b> AISI 316 Stainless Steel
Trigger	<b>B3</b> AISI 316 Stainless Steel, rubber lined

### TECHNICAL DATA

Hose shank	13 mm	
Weight	0.9 kg	
Max temperature	95° C	PERFORMANCE
Max pressure	24 bar	21 lpm @ 3 bar UMV 2210
		61 lpm @ 3 bar UMV 2211

## UMV SERIES HOT WATER SPRAY GUNS

Functional spray guns match front shut-off extensions for foam, hot water and general use.

CODE	FEATURES
<b>UMV 2210 xx</b>	Standard, adjustable jet
<b>UMV 2211 xx</b>	With 1/2" male quick thread, without lance
<b>UMV 220A xx</b>	With foam lance
<b>UMV 220B xx</b>	With 1/4" female outlet, bare lance
<b>UMV 220C xx</b>	With 1/4" female outlet, heat protected lance

Please note that codes endind with **(xx)** must be completed with the code of the material, substituting the **(xx)** with the code **T2** for crome plated brass or **B31** for AISI 316L stainless steel.

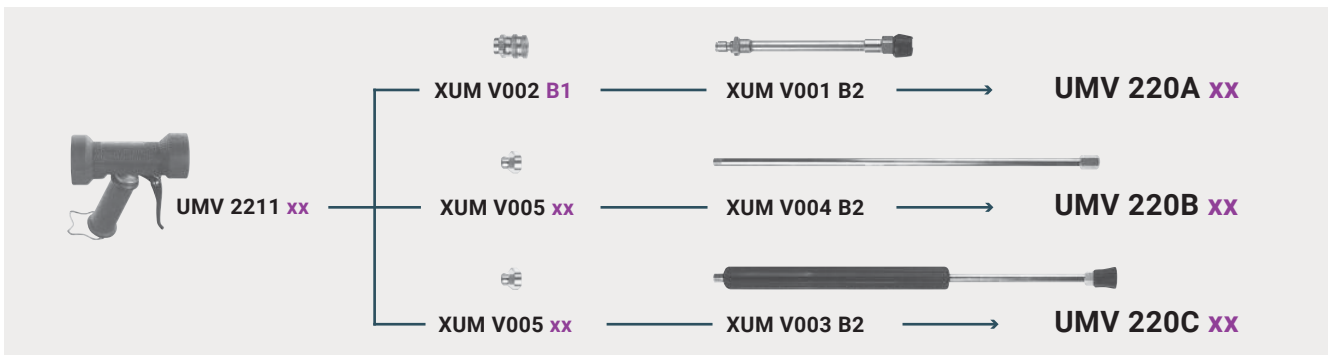

## SINGLE COMPONENTS

CODE	COMPONENTS
<b>XUM V001 B2</b>	Foam lance, AISI 304
<b>XUM V002 B1</b>	Quick connect coupling for foam lance, 1/2" F, AISI 303
<b>XUM V003 B2</b>	Universal lance, 1/4" F out, heat protention, AISI 304
<b>XUM V004 B2</b>	Universal lance, 1/4" F out, AISI 304
<b>XUM V005 xx</b>	Nipple, 1/4" F x 1/2" F

Please note that codes endind with **(xx)** must be completed with the code of the material, substituting the **(xx)** with the code **T8** for nichel plated brass or **B31** for AISI 316L stainless steel.

( HOT WATER SPRAY GUN ACCESSORIES ) **XUM**

HOT WATER SPRAY GUN ACCESSORIES

FLEXIBLE HOSE

This hose has been selected to be used with all models of UMV hot water spray-gun as it's made in top quality EPDM to outwear oil, high temperatures, high pressures and assure a long service life. Inlet and outlet ends are provided with female quick couplings for easy assembly and safety.



MAX WORKING TEMPERATURE LT 160°C  
 MAX WORKING PRESSURE LP 8 bar  
 MATERIAL Hose **E0** EPDM  
 Couplings **B3** AISI 316 Stainless Steel

CODE	Size (inch)	Hose length (m)
<b>XUM VT25 E0</b>	1/2"	25
<b>XUM VT20 E0</b>	3/4"	20

HOSE STAND

XUM quick couplings are hot water spray gun accessories. It is convenient to assemble nozzle and spray gun.

MATERIAL **B2** AISI 304 Stainless Steel

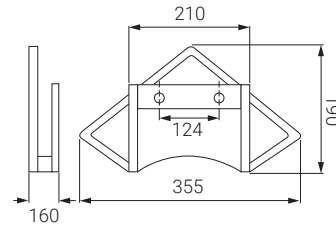

**XUM US10 B2**

( PORTABLE WATER GUN ) **UMS**

PORTABLE WATER SPRAY GUN

Le UMS portable water spray-guns are widely used in industry. They have a lock ring to fix the handle while operating for a comfortable long use. The gun has a 1/2" female thread for nozzles assembly. The most common applications of this spray-gun are:

1. Blowing off of water and surface dust with a UEA 0525 E31 air nozzles
2. Parts and environment cleaning with suitable flat fan nozzles
3. Liquid filling or packing with proper complementary accessories

TYPICAL APPLICATIONS Product cleaning  
 Liquid addition  
 Air spray gun

INLET / OUTLET THREAD SIZE 1/2" BSP  
 MAX WORKING TEMPERATURE LT 100°C  
 MAX WORKING PRESSURE LP 50 bar  
 MAX CAPACITY LQ 70 l/min  
 WEIGHT W 0.17 / 0.25 kg  
 MATERIAL Inner parts **B1** AISI 303 Stainless Steel  
 Inside seal **E7** Viton  
 Outside shell **E3** Acetalic resin

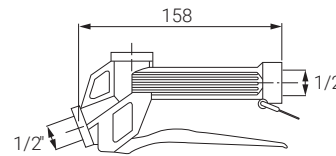

**With flat fan nozzle**



**With lance**



**With UEA 0525 E31 air nozzle**

# UMU A / B ( MANUAL REWIND HOSE REELS )



**UMU AD20 B2HSB**  
Spray gun is not included

## UMU A/B - MANUAL REWIND HOSE REELS

UMU A/B models are basic manual rewind hose reels. The hose can be pulled out to the desired length, oriented for release and safely returned into initial position after use. It can be assembled on a mobile cart or fixed to floor, wall or ceiling. Its construction is industrial grade, it's safe for operators, wear-resistant, and leak-free. They are specially designed for swivel nozzles and can be customized in length, materials, operating pressure and temperature to satisfy your requirements.

TYPICAL APPLICATIONS	Food factories, washing lines, car wash
THREAD SPECIFICATION	BSP , NPT
INLET THREAD SIZE	1/2", 1"
OUTLET THREAD SIZE	1/2", 1"
FLEXIBLE HOSE SIZE	3/8", 1/2", 1"
MAX HOSE LENGTH	70 M
MAX WORKING PRESSURE	LP 200 bar
MATERIAL	Body <b>B2</b> AISI 304 Stainless Steel

CODE	LP bar	E inch	U inch	DI mm	MF inch	LF m	W kg	DE mm	H mm	S mm	Swivel code
<b>UMU BF10 B2LSB</b>	20	1"	1"	20	1"	10	12	500	460	270	on request
<b>UMU BF20 B2LSB</b>					1"	20	13	500	460	340	
<b>UMU AC20 B2HSB</b>	200	1/2"	1/2"	10	3/8"	20	9	390	330	300	
<b>UMU AD20 B2HSB</b>					1/2"	20					
<b>UMU BC50 B2HSB</b>					3/8"	50	12	500	460	270	
<b>UMU BD35 B2HSB</b>					1/2"	35					
<b>UMU BC70 B2HSB</b>					3/8"	70	13	500	460	340	
<b>UMU BD50 B2HSB</b>					1/2"	50					

# UMU G / H ( AUTO-REWIND HOSE REELS )



**UMU HD20 B2HSB**

## UMU G/H - AUTO-REWIND HOSE REELS

UMU G/H models are auto-rewind hose reels with multi-position release, very useful and practical for frequent cleaning operations. The hose can be easily pulled out from the reel for the desired length and locked in place during use. When washing is completed, a short further pull activates a spring powered automatic rewind mechanism that returns the hose onto the reel. It's suitable for a variety of industrial environments, wear-resistant, robust in construction and designed to mount floor, wall, ceiling or cart.

TYPICAL APPLICATIONS	Food factories, washing lines, car wash
THREAD SPECIFICATION	BSP , NPT
INLET THREAD SIZE	1/2", 1"
OUTLET THREAD SIZE	1/2", 1"
FLEXIBLE HOSE SIZE	3/8", 1/2", 3/4", 1"
MAX HOSE LENGTH	20 M
MAX WORKING PRESSURE	LP 200 bar
MATERIAL	Corpo <b>B2</b> AISI 304 Stainless Steel

CODE	LP bar	E inch	U inch	DI mm	MF inch	LF m	W kg	DE mm	H mm	S mm	Swivel code
<b>UMU HE 13 B2LSB</b>	20	1"	1"	20	3/4"	13	18	530	550	300	XUM US20 B2
<b>UMU HF 08 B2LSB</b>					1"	8	18				
<b>UMU HE 18 B2LSB</b>	20	1"	1"	20	3/4"	18	24	530	550	480	XUM US22 B2
<b>UMU HF15 B2LSB</b>					1"	15	24				
<b>UMU GD15 B2HSB</b>	200	1/2"	1/2"	10	1/2"	15	13	550	430	230	XUM US15 B2
<b>UMU GD20 B2HSB</b>					1/2"	20	18	550	430	260	XUM US20 B2
<b>UMU HC20 B2HSB</b>					3/8"	20	18	530	550	300	
<b>UMU HD20 B2HSB</b>					1/2"	20	18	530	550	300	

( AUTO-REWIND ADJUSTABLE HOSE REELS ) **UMU L / K**

UMU L/K - AUTO-REWIND ADJUSTABLE HOSE REELS

UMU L/K models are hose reels with spring powered automatic rewind and adjustable release, suitable for industrial environments requiring efficient cleaning power. They provide quick hose direction and retraction, are wear-resistant, leak-free and handy to use. The hose can be pulled to the desired length and locked in place during use. When operation is completed, a short further pull activates a spring powered automatic rewind mechanism that returns the hose onto the reel.

UMU L/K hose reels are specially designed for swivel nozzles and can be customized in length, materials, operating pressure and temperature to satisfy your requirements.

TYPICAL APPLICATIONS	Food factories, washing lines, car wash
INLET THREAD SIZE	1/2", 1"
OUTLET THREAD SIZE	1/2", 1"
FLEXIBLE HOSE SIZE	1/2", 3/4", 1"
MAX HOSE LENGTH	20 M
MAX WORKING PRESSURE	LP 200 bar
MATERIAL	Body <b>B2</b> AISI 304 Stainless Steel



**UMU KD20 B2HSB**

CODE	LP bar	E inch	U inch	DI mm	MF inch	LF m	W kg	DE mm	H mm	S mm	Swivel code
<b>UMU LE13 B2LSB</b>	20	1"	1"	20	3/4"	13	18	530	550	300	XUM US20 B2
<b>UMU LF08 B2LSB</b>					1"	8	18				
<b>UMU LE18 B2LSB</b>	20	1"	1"	20	3/4"	18	24	530	550	480	XUM US22 B2
<b>UMU LF15 B2LSB</b>					1"	15	24				
<b>UMU KD15 B2HSB</b>	200	1/2"	1/2"	10	1/2"	15	13	500	480	250	XUM US15 B2
<b>UMU KD20 B2HSB</b>						20	18	500	480	280	XUM US20 B2

( LARGE CAPACITY AUTO-REWIND HOSE REELS ) **UMU J / I**

UMU J/I - LARGE CAPACITY AUTO-REWIND HOSE REELS

UMU J/I large capacity auto-rewind hose reels are recommended for working environments requiring a large capacity. UMU J/I reels have been designed to hold flexible and long hoses up to 40 meters (depending on hose diameter), and have a double retraction spring that ensure a quick and reliable hose auto-rewinding.

They are robust, wear-resistant, leak-free, powerful and adjustable. Ideal to clean long tunnels or machines from a single water feed point. They can be customized in length, materials, operating pressure and temperature to satisfy your requirements.

TYPICAL APPLICATIONS	Food factories, washing lines, car wash
INLET THREAD SIZE	1/2", 1"
OUTLET THREAD SIZE	1/2", 1"
FLEXIBLE HOSE SIZE	3/8", 1/2", 3/4", 1"
MAX HOSE LENGTH	40 M
MAX WORKING PRESSURE	LP 200 bar
MATERIAL	Body <b>B2</b> AISI 304 Stainless Steel



**UMU ID40 B2HSB**

*Spray gun is not included*

CODE	LP bar	E inch	U inch	DI mm	MF inch	LF m	W kg	DE mm	H mm	S mm	Swivel code
<b>UMU JE30 B2LSB</b>	20	1"	1"	20	3/4"	30	40	530	550	520	Please contact our Sales Dept
<b>UMU JF25 B2LSB</b>				20	1"	25					
<b>UMU ID25 B2HSB</b>	200	1/2"	1/2"	10	1/2"	25	26	530	550	370	
<b>UMU IC40 B2HSB</b>				10	3/8"	40	36				
<b>UMU ID40 B2HSB</b>				10	1/2"	40	36	530	550	420	





VISIT OUR WEBSITE  
**WWW.PNR.EU**

The best way to stay update on all the news  
and developments of the company!

Constant updates

*Product pages, news, industries, case studies*

User friendly

*You can easily find the product you need*

100% responsive

*It can be accessed by any connected device*



CONSTANT  
UPDATES

USER  
FRIENDLY



100% RESPONSIVE

DISCOVER OUR CERTIFICATIONS



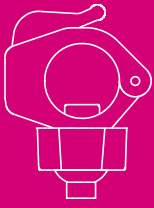

# CLIP-ON NOZZLES



Diversified manufacturing is a competitiveness key-factor today. PNR Italy manufactures several diversified products to meet all costumers' needs and help them achieve their production targets. Its complete product range includes clip-on nozzles which now widely used by European and American automobile manufacturers. In the automobile industry the coating lines are representative of diversified production requiring timely adjustments of nozzles spray direction and coverage. Moreover, in such operating environments, nozzles must be regularly cleaned and serviced to ensure high quality coating.

To satisfy such requirements PNR has developed cutting-edge quality products to enhance the productivity and competitiveness of the production plant. PNR clip-on adjustable nozzles, made with innovative design and in top quality materials, shorten installation, adjustment and servicing times to the benefit of production efficiency. These nozzles are installed on pipes and can be rapidly released and changed at any time or easily adjusted to different production conditions.

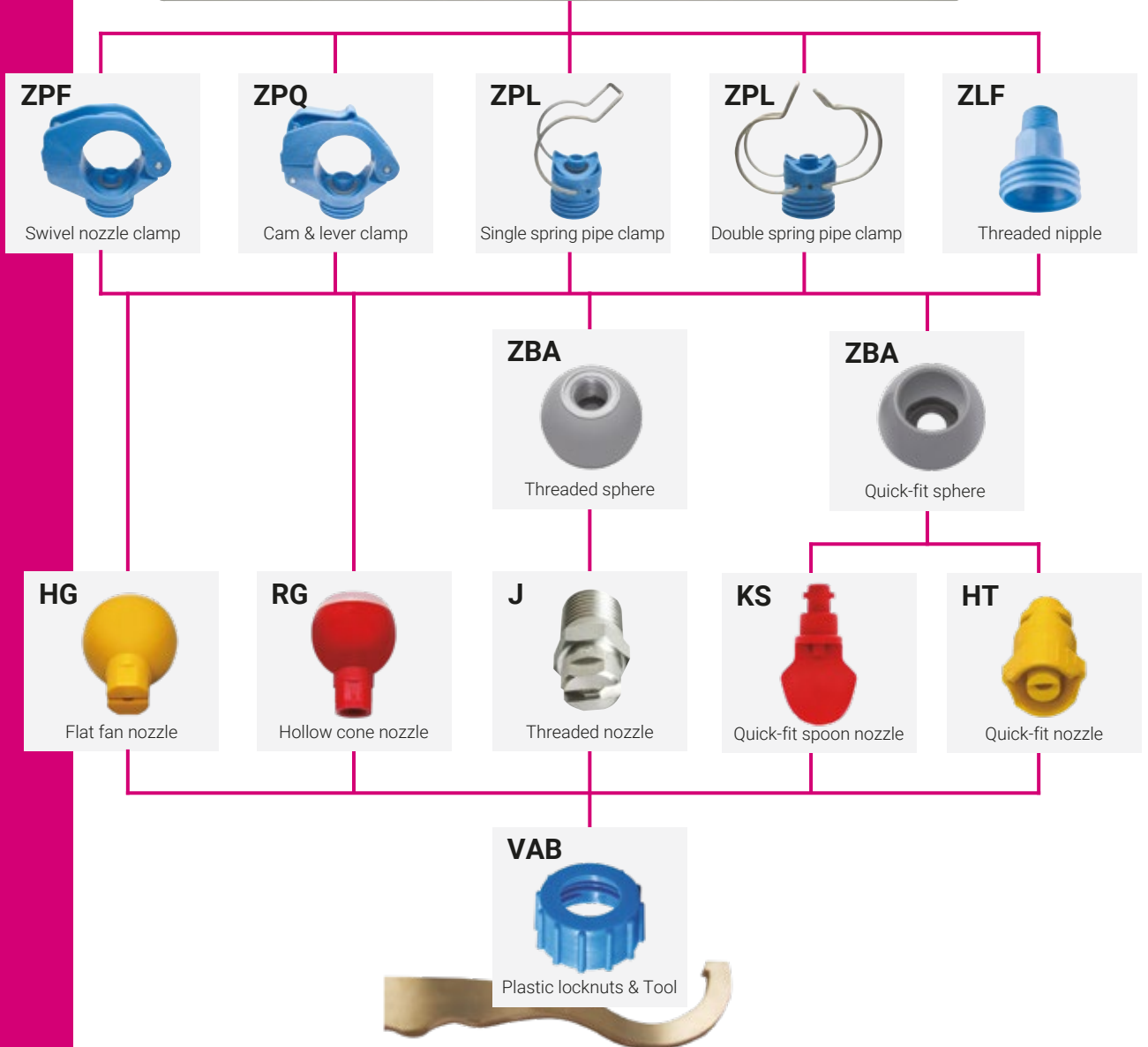

( SWIVEL NOZZLE CLAMPS ) **ZPF**

SWIVEL NOZZLE CLAMPS

ZPF swivel clamps are specially designed for HGQ, RGN and ZBA series. To install them on pipes all you need is drill a hole, insert the nozzle clamp inside and fasten it with a simple screwdriver. The nozzle clamp body is in PP chemically bonded fibreglass whereas accessorial bolts and screws are made in stainless steel AISI 316. They are robust, easy to install, adjust and service and their design revolutioned modern surface pre-treatment plants. They provide excellent performance at high temperatures and easy spray jet orientation.

TYPICAL APPLICATION                      Cleaning equipment used in pre-treatment for coating process

MAX WORKING TEMPERATURE              LT 90°C

MAX WORKING PRESSURE                    LP 5 bar

MATERIAL                      Body                      **D6** PP, chemically bonded fibreglass

   Pin & bolt                      **B3** AISI 316 Stainless Steel

   O-ring                      **E8** NBR

CODE	PS inch	PD mm	D mm	H mm	H1 mm	L mm	A deg	W g
<b>ZPF A125 D6</b>	1 1/4"	41/43	20.0	83	54	84	40°	85
<b>ZPF B125 D6</b>			17.0					
<b>ZPF C125 D6</b>			14.0					
<b>ZPF A150 D6</b>	1 1/2"	46/49	20.0	90	57	90	40°	88
<b>ZPF B150 D6</b>			17.0					
<b>ZPF C150 D6</b>			14.0					

HOW TO MAKE UP THE PRODUCT CODE              Ex.: ZPF A125 D6

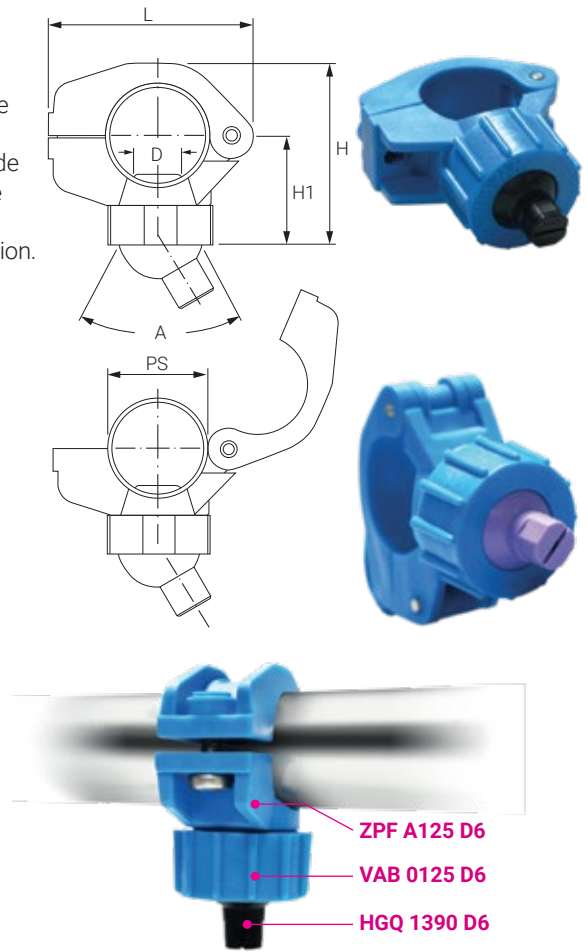
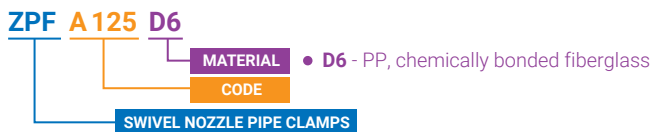

( SWIVEL NOZZLE CAM AND LEVER CLAMPS ) **ZPQ**

SWIVEL NOZZLE CAM AND LEVER CLAMPS

ZPQ cam and lever clamps are specially designed for HGQ, RGN and ZBA ball nozzles. Only three steps to install them on a pipe: drill a hole, wrap the cam around the pipe and pull the lever down to block it. No need of tools. The body is in PP chemically bonded fibreglass whereas accessorial bolts and screws are made in stainless steel AISI 316. ZPQ swivel nozzles with cam and lever clamps provide excellent performance at high temperatures and easy spray jet orientation.

COMMON APPLICATION                      Surface pre-treatment plants

MAX WORKING TEMPERATURE              LT 90°C

MAX WORKING PRESSURE                    LP 5 bar

MATERIAL                      Body                      **D6** PP, chemically bonded fibreglass

   Pin & bolt                      **B3** AISI 316 Stainless Steel

   O-ring                      **E8** NBR

   Seal                      **D22** Soft polypropylene

CODE	PS inch	PD mm	D mm	H mm	H1 mm	L mm	A deg	W g
<b>ZPQ A125 D6</b>	1 1/4"	42/43	20.0	93	41	84	40°	87
<b>ZPQ B125 D6</b>			17.0					
<b>ZPQ A150 D6</b>	1 1/2"	48/49	20.0	96	44	95	40°	97
<b>ZPQ B150 D6</b>			17.0					

HOW TO INSTALL THE SWIVEL NOZZLE CAM & LEVER CLAMPS

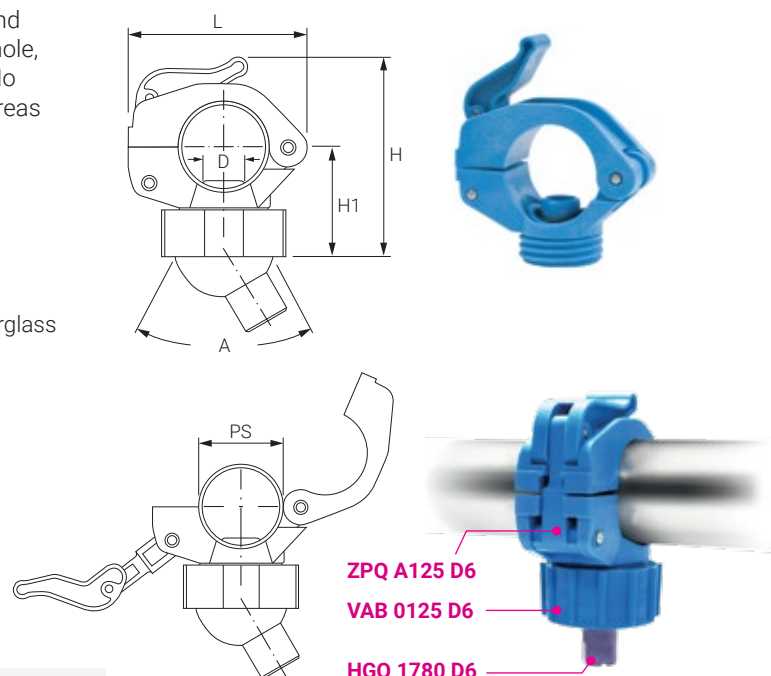
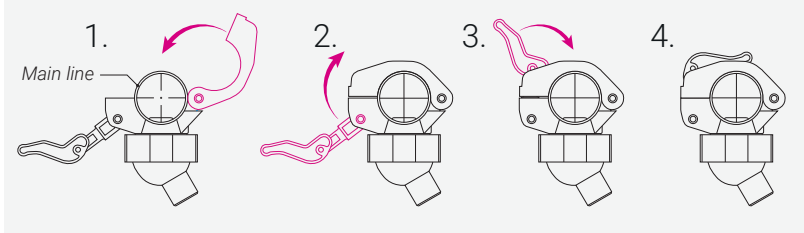



# ZPL (SWIVEL NOZZLE SPRING PIPE CLAMPS)



ZPL Single spring

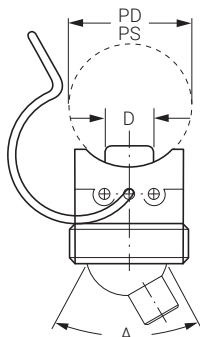

ZPL Double spring Better stability

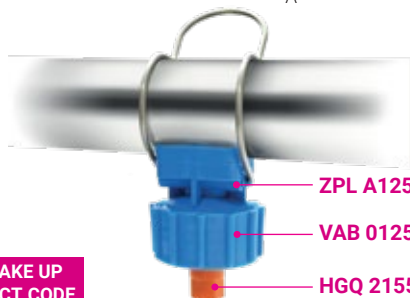
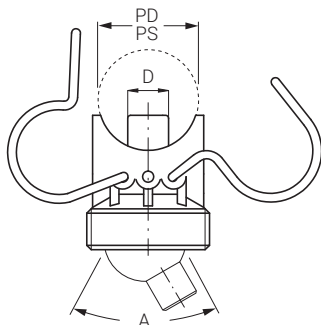

ZPL A125 D6 S1B  
VAB 0125 D6  
HGQ 2155 D5

**HOW TO MAKE UP THE PRODUCT CODE**

ZPL A 100 D6 X Y Z

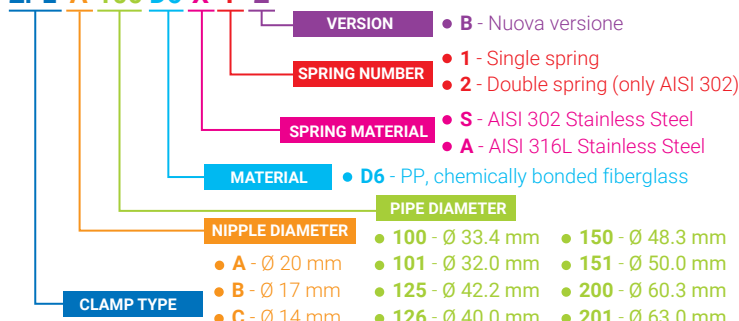

## SWIVEL NOZZLE SPRING PIPE CLAMPS

ZPL pipe clamps are specially designed for swivel ball nozzles. Drill a hole and fix the clamp with one screw. Body is made of fibreglass reinforced PP, screw and spring in AISI 316L (or AISI 302). ZPL swivel nozzles work under high temperature and high degree of intensity. ZPL swivel nozzle pipe clamps are widely used in surface pre-treatment.

TYPICAL APPLICATION Cleaning equipment used in pre-treatment for coating process

MAX WORKING TEMPERATURE LT 80°C  
MAX WORKING PRESSURE Single spring 3 bar  
Double spring 7 bar

MATERIAL Body D6 PP, chemically bonded fiberglass  
Spring N1 AISI 302 Stainless Steel  
O-ring B31 AISI 316L Stainless Steel  
E8 NBR

CODE	PS		PD mm	D mm	A deg
	inch	DN			
ZPL A100 D6 XYZ	1"	DN25	33.4	20.0	40°
ZPL B100 D6 XYZ	1"	DN25	33.4	17.0	40°
ZPL C100 D6 XYZ	1"	DN25	33.4	14.0	40°
ZPL A101 D6 XYZ	1"	DN25	32.0	20.0	40°
ZPL B101 D6 XYZ	1"	DN25	32.0	17.0	40°
ZPL C101 D6 XYZ	1"	DN25	32.0	14.0	40°
ZPL A125 D6 XYZ	1 1/4"	DN32	42.2	20.0	40°
ZPL B125 D6 XYZ	1 1/4"	DN32	42.2	17.0	40°
ZPL C125 D6 XYZ	1 1/4"	DN32	42.2	14.0	40°
ZPL A126 D6 XYZ	1 1/4"	DN32	40.0	20.0	40°
ZPL B126 D6 XYZ	1 1/4"	DN32	40.0	17.0	40°
ZPL C126 D6 XYZ	1 1/4"	DN32	40.0	14.0	40°
ZPL A150 D6 XYZ	1 1/2"	DN40	48.3	20.0	40°
ZPL B150 D6 XYZ	1 1/2"	DN40	48.3	17.0	40°
ZPL C150 D6 XYZ	1 1/2"	DN40	48.3	14.0	40°
ZPL A151 D6 XYZ	1 1/2"	DN40	50.0	20.0	40°
ZPL C151 D6 XYZ	1 1/2"	DN40	50.0	14.0	40°
ZPL A200 D6 XYZ	2"	DN50	60.3	20.0	40°
ZPL B200 D6 XYZ	2"	DN50	60.3	17.0	40°
ZPL C200 D6 XYZ	2"	DN50	60.3	14.0	40°
ZPL A201 D6 XYZ	2"	DN50	63.0	20.0	40°
ZPL B201 D6 XYZ	2"	DN50	63.0	17.0	40°
ZPL C201 D6 XYZ	2"	DN50	63.0	14.0	40°

# VAB (PLASTIC LOCKNUTS)

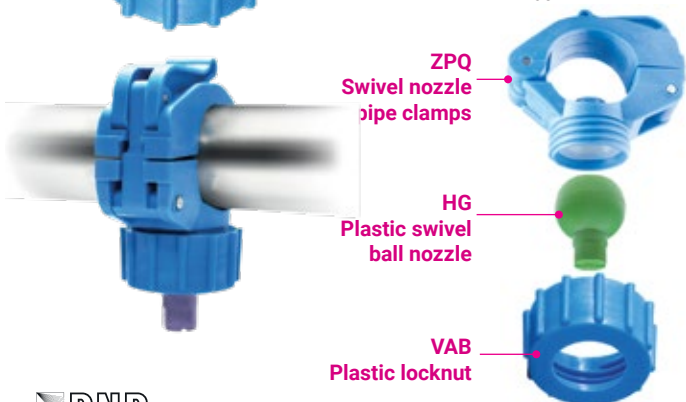
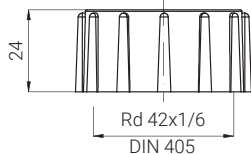

ZPQ Swivel nozzle pipe clamps  
HG Plastic swivel ball nozzle  
VAB Plastic locknut

## PLASTIC LOCKNUTS

VAB plastic locknuts are exclusively designed for ball nozzles. Their special thread and shape allow to assemble the cap and by hand, with no need of tools, thus making all servicing operations easier and quicker. They are made of high quality PP or chemically bonded fiberglass to keep stability at high temperatures and offer the best resistance to chemicals.

MATERIAL D6 PP, caricato fibravetro  
MAX WORKING TEMPERATURE LT 80°C

**HOW TO MAKE UP THE PRODUCT CODE** Ex.: VAB 0125 D6





( SWIVEL NOZZLE THREADED NIPPLE ) **ZLF**

SWIVEL NOZZLE THREADED NIPPLE

ZLF series threaded nipples offer another convenient type of installation for swivel ball nozzles. They are made of fibreglass reinforced PP. ZLF series work under high temperature and high degree of intensity. ZLF threaded nipples are widely used in surface pre-treatment.

TYPICAL APPLICATION Cleaning equipment used in pre-treatment for coating process  
 MATERIAL **D6** PP, chemically bonded fiberglass

CODE	RG inch BSPT	RG inch NPT	W g
ZLF A038 D6	3/8"	-	15
ZLF B038 D6	-	3/8"	
ZLF A050 D6	1/2"	-	
ZLF B050 D6	-	1/2"	

MAX WORKING TEMPERATURE  
 LP 4 bar  
 MAX WORKING TEMPERATURE  
 LT 90°C

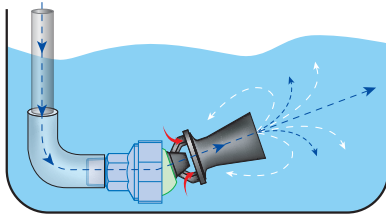
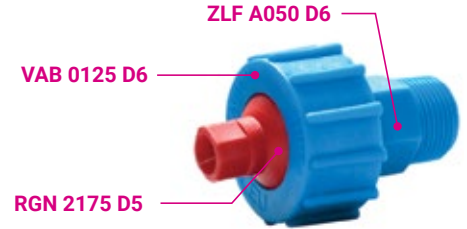
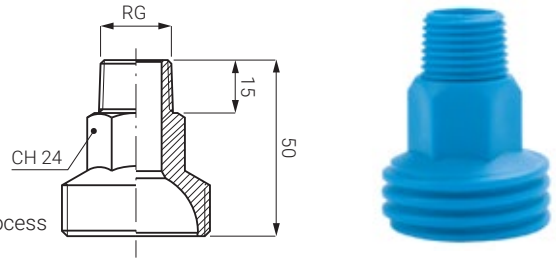

ZLF threaded nipples offer the best mixing effect and are often used in combination with UPB mixing eductors.



( PLASTIC END CAPS ) **VAE**

PLASTIC END CAPS

VAE plastic caps are specially used to close pipes ends. Besides, 1 1/4" VAE 1250 D6 plastic caps can be used to seal pipes ends when, to manufacture different size products, it's necessary to reduce the quantity of swivel nozzles. They are made of high quality PP or chemically bonded fiberglass to keep stability at high temperatures and offer the best resistance to chemicals. They are widely used in surface pre-treatment.

MATERIAL **D6** PP, chemically bonded fiberglass  
 MAX WORKING TEMPERATURE LT 90°C

CODE	RF inch	H mm	CH mm
VAE 0100 D6	1"	25	42
VAE 0125 D6	1 1/4"	32	52
VAE 0150 D6	1 1/2"	32	60

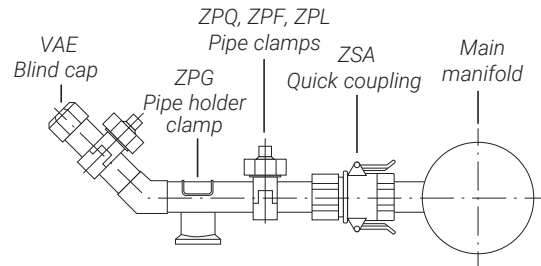
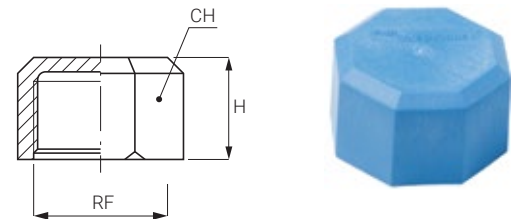

( THREADED AND QUICK-FIT SPHERES ) **ZBA**

THREADED AND QUICK-FIT SPHERES

ZBA swivel nozzles are produced with three different types of connections: threaded, quick-fit and blind hole. The threaded nozzles are assembled to threaded swivel joints. The quick-fit types are designed for HTQ/KSQ quick-fit flat fan nozzles whereas the blind hole models are specially used in spraying processes requiring changes and pauses.

CODE	CONNECTION			TYPE	L mm	D mm	H mm
	RF/RG	M/F	BSP/NPT				
ZBA 0000 D5x	Blind	---	---	---	35.0	17.5	27.5
ZBA 0039 D5	3/8"	M	BSP	Mobile	35.0	20.0	27.3
ZBA GAT1 D5x	1/8"	F	BSP	Mobile	35.0	20.0	27.3
ZBA GBT1 D5x	1/4"	F	BSP	Mobile	35.0	20.0	27.3
ZBA GCT1 D5x	3/8"	F	BSP	Mobile	35.0	20.0	27.3
ZBA GDT1 D5x	1/2"	F	BSP	Mobile	35.0	20.0	27.3
ZBA NAT1 D5x	1/8"	F	NPT	Mobile	35.0	20.0	27.3
ZBA NBT1 D5x	1/4"	F	NPT	Mobile	35.0	20.0	27.3
ZBA NCT1 D5x	3/8"	F	NPT	Mobile	35.0	20.0	27.3
ZBA NDT1 D5x	1/2"	F	NPT	Mobile	35.0	20.0	27.3
ZBA GAT2 D5x	1/8"	F	BSP	Fissa	27.4	26.0	35.1
ZBA GBT2 D5x	1/4"	F	BSP	Fissa	27.4	26.0	35.1
ZBA GCT2 D5x	3/8"	F	BSP	Fissa	27.4	26.0	35.1
ZBA GDT2 D5x	1/2"	F	BSP	Fissa	27.4	26.0	35.1
ZBA QQN2 D6	Quick	---	---	Mobile	35.0	23.4	27.0

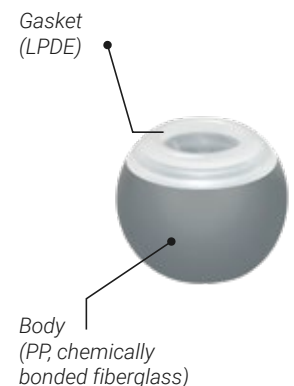

# ZPN ( SPRING PIPE CLAMPS )



ZPN Single spring

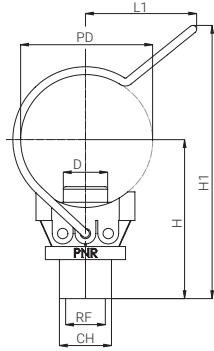

ZPN Double spring  
Better stability

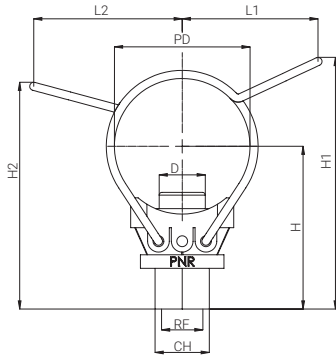

ZPN MINI Single spring

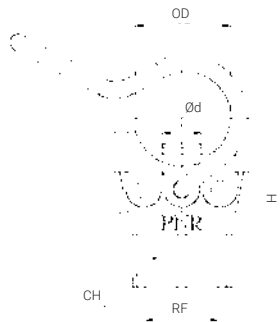

CODE AND DIMENSION FOR ZPN

CODE	RF	PS		PD	D	CH
	inch	inch	DN			
ZPN B151 D6C1	3/8" F	1 1/2"	DN40	48.2 - 50.0	17.0	20
ZPN B151 D6D1	1/2" F	1 1/2"	DN40	48.2 - 50.0	17.0	26
ZPN B151 D6C2	3/8" F	1 1/2"	DN40	48.2 - 50.0	17.0	20
ZPN B151 D6D2	1/2" F	1 1/2"	DN40	48.2 - 50.0	17.0	26

## SPRING PIPE CLAMPS

ZPN spring clamps provide quick connection of 3/8" and 1/2" male threaded nozzles to 1 1/2" pipes. Geometrical characteristics of ZPN are same as ZPL in connection pipe side. Single or double spring versions are available. ZPN pipe clamps are widely used in pre-treatment for coating process.

TYPICAL APPLICATION	Cleaning equipment used in pre-treatment for coating process
MAX WORKING TEMPERATURE	LT 90°C
MAX WORKING PRESSURE	Single spring 3 bar Double spring 7 bar
MATERIAL	Body <b>D6</b> PP, chemically bonded fiberglass Spring <b>N1</b> AISI 302 Stainless Steel O-ring <b>B31</b> AISI 316L Stainless Steel <b>E8</b> NBR

## MINI SPRING PIPE CLAMPS

ZPN MINI spring clamps provide quick connection of 1/8", 1/4", 3/8" and 1/2" female threaded to 1/2", 3/4" and 1" pipes. It's enough make one hole on pipe, insert the clamp with the seal and fix to pipe with the spring. Up to now, only single spring model is available. Models are made of different colours, depending on pipe size (yellow clamp for pipe size 1/2", green clamp for pipe size 3/4", blue clamp for pipe size 1").

TYPICAL APPLICATION	Cleaning equipment used in pre-treatment for coating process
MAX WORKING TEMPERATURE	LT 90°C
MAX WORKING PRESSURE	LP 5 bar
MATERIAL	Body <b>D6</b> PP, chemically bonded fiberglass Spring <b>B3</b> AISI 316 Stainless Steel O-ring <b>E8</b> NBR

CODE AND DIMENSION FOR ZPN MINI

CODE	RF	OD	Ød	CH	H	COLOUR
	inch	inch	mm	mm	mm	
ZPN E050 D6AMA	1/8" F	1/2"	9.00	16	38.0	YELLOW
ZPN E050 D6BMA	1/4" F	1/2"	9.00	18	38.0	
ZPN E050 D6CMA	3/8" F	1/2"	9.00	22	38.0	
ZPN E050 D6DMA	1/2" F	1/2"	9.00	24	38.0	
ZPN D075 D6AMA	1/8" F	3/4"	11.0	16	41.0	GREEN
ZPN D075 D6BMA	1/4" F	3/4"	11.0	18	41.0	
ZPN D075 D6CMA	3/8" F	3/4"	11.0	22	41.0	
ZPN D075 D6DMA	1/2" F	3/4"	11.0	24	41.0	
ZPN F100 D6AMA	1/8" F	1"	13.0	16	45.0	BLUE
ZPN F100 D6BMA	1/4" F	1"	13.0	18	45.0	
ZPN F100 D6CMA	3/8" F	1"	13.0	22	45.0	
ZPN F100 D6DMA	1/2" F	1"	13.0	24	45.0	

HOW TO MAKE UP THE PRODUCT CODE

ZPN

ZPN B 151 D6 X Y Z

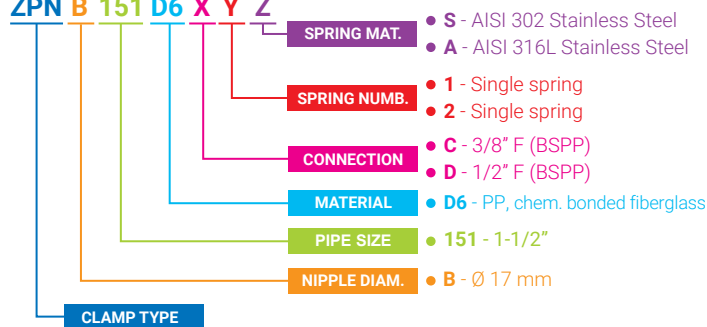

HOW TO MAKE UP THE PRODUCT CODE

ZPN MINI

ZPN E 050 D6 X Y Z

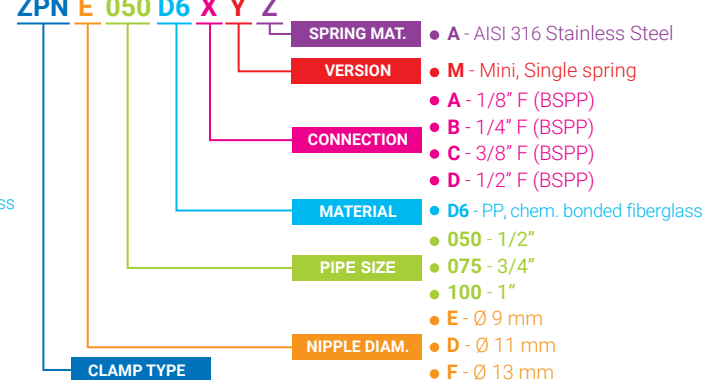

# (MINI QUICK-FIT NOZZLES) DT/QM, HT/QM

## MINI QUICK-FIT NOZZLES

DT/QM full cone spray nozzles and HT/QM flat fan spray nozzles, assembled onto a nipple with 3/8", 1/4" e 1/8" BSPT connections, offer the convenience of a quick coupling which allows a simple assembly. Moreover, the special seal between nipple and nozzle avoids any risk of leakage. To allow a perfect spray pattern alignment, the spray jet has an offset angle of 10° from the hexagon of the nipple onto which the nozzle is assembled. This type of nozzles are extremely convenient for maintenance and can be quickly replaced in case of clogging. The various flow rates of these nozzles are marked by different colours. They are made in glass fibre-reinforced PP to ensure maximum stability at high temperatures and chemical resistance.

MATERIAL **D6** PP, chemically bonded fiberglass  
 NIPPLE DIMENSIONS 1/8", 1/4", 3/8" BSPT  
 MAX TEMP. D'ESERCIZIO LT 90 °C  
 TYPICAL APPLICATION

*Washing:* food cleaning, parts cleaning, filter cloth cleaning, vehicles cleaning  
*Lubrication:* spray of lubricants and release agents  
*Agriculture:* spray of antifouling chemicals  
*Cooling:* product cooling  
*Other applications:* spray of chemicals



DT/QM  
+  
Gasket  
+  
Nipple

HT/QM  
+  
Gasket  
+  
Nipple

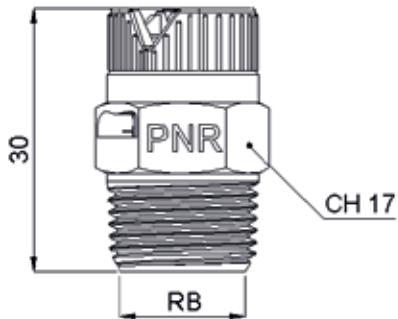

	CODE	Capacity at different pressure values (l/min) (bar)					Colour	
		1.0	2.0	3.0	4.0	5.0		
45°	DTx 0780 D6QM	0.45	0.64	0.78	0.90	1.01	GREY	
	DTx 1100 D6QM	0.58	0.82	1.00	1.15	1.29	BROWN	
	DTx 1120 D6QM	0.69	0.98	1.20	1.39	1.55	BLACK	
	DTx 1150 D6QM	0.87	1.22	1.50	1.73	1.94	LIGHT ORANGE	
	DTx 1190 D6QM	1.10	1.55	1.90	2.19	2.45	LIGHT GREEN	
	65°	DTx 1235 D6QM	1.36	1.92	2.35	2.71	3.03	LIGHT YELLOW
		DTx 1294 D6QM	1.70	2.40	2.94	3.39	3.80	SKY BLUE
		DTx 1370 D6QM	2.14	3.02	3.70	4.27	4.78	WHITE
	90°	DTx 1470 D6QM	2.71	3.84	4.70	5.43	6.07	RED
		DTx 1590 D6QM	3.41	4.82	5.90	6.81	7.62	DARK GREY
		DTx 1740 D6QM	4.27	6.04	7.40	8.54	9.55	BROWN/BLACK
		DTx 2112 D6QM	6.47	9.14	11.2	12.9	14.5	RED ORANGE

ANGLE	CODE	Capacity at different pressure values (l/min) (bar)					Colour	
		1.0	2.0	3.0	4.0	5.0		
65°	HTx 0780 D6QM	0.45	0.64	0.78	0.78	1.01	GREY	
	HTx 1100 D6QM	0.58	0.82	1.00	1.15	1.29	BROWN	
	HTx 1120 D6QM	0.69	0.98	1.20	1.39	1.55	BLACK	
	HTx 1160 D6QM	0.92	1.31	1.60	1.85	2.07	LIGHT ORANGE	
	HTx 1190 D6QM	1.10	1.55	1.90	2.19	2.45	LIGHT GREEN	
	HTx 1233 D6QM	1.35	1.90	2.33	2.69	3.01	LIGHT YELLOW	
	HTx 1310 D6QM	1.79	2.53	3.10	3.58	4.00	SKY BLUE	
	HTx 1390 D6QM	2.25	3.18	3.90	4.50	5.03	WHITE	
	90°	HTx 1590 D6QM	3.41	4.82	5.90	6.81	7.62	DARK GREY
		HTx 1780 D6QM	4.50	6.37	7.80	9.01	10.1	BROWN/BLACK
	110°	HTx 1980 D6QM	5.66	8.00	9.80	11.3	12.7	PURPLE
		HTx 2117 D6QM	6.75	9.55	11.7	13.5	15.1	RED ORANGE
HTx 2135 D6QM		7.79	11.0	13.5	15.6	17.4	LILAC	
HTx 2153 D6QM		8.83	12.5	15.3	17.7	19.8	GREEN	
HTx 2195 D6QM		11.3	15.9	19.5	22.5	25.2	YELLOW	
HTx 2230 D6QM		13.3	18.8	23.0	26.6	29.7	BLUE	
HTx 2280 D6QM		16.2	22.9	28.0	32.3	36.1	RED	

### HOW TO MAKE UP THE PRODUCT CODE

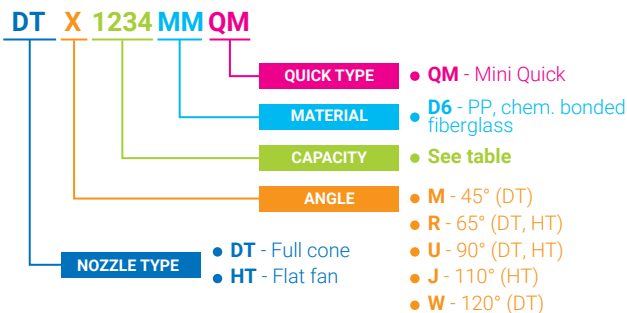

### HOW TO MAKE UP THE PRODUCT CODE

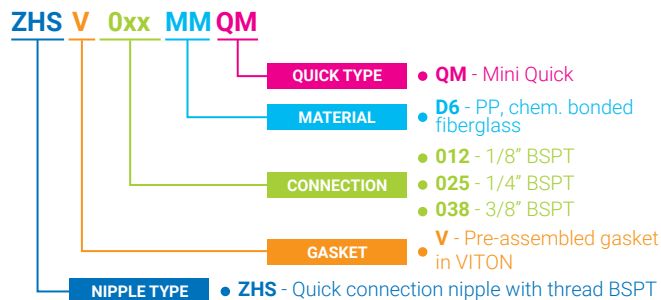

**NOTA:** each nozzle, both DT/QM and HT/QM, of any capacity, can be mounted on all three types of nipples.

# HG, RG ( PLASTIC SWIVEL BALL NOZZLES )



**HGQ 2117 D5**  
Flat fan nozzle

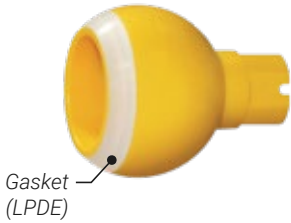
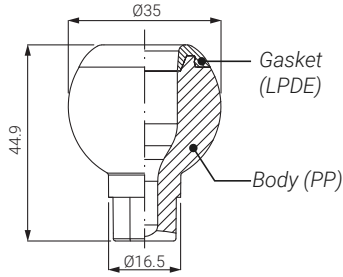

Gasket (LPDE)

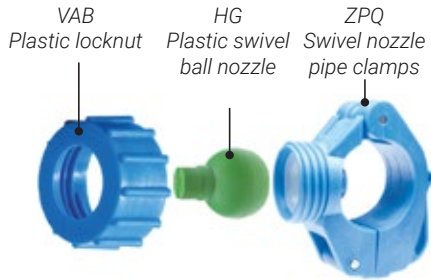
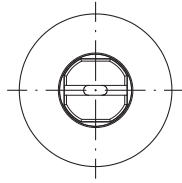

Spray section

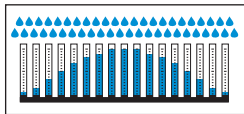

Convex distribution



## PLASTIC SWIVEL BALL NOZZLES

HGQ and RGN plastic swivel ball nozzles are designed for diversified applications. They allow an easy adjustment of their spray jet direction and offer a quick-fit connection.

NOZZLE TYPE	Flat fan nozzles (HG), Hollow cone nozzles (RG)
TYPICAL APPLICATION	Cleaning equipment used in pre-treatment for coating process
MATERIAL	Body <b>D5</b> PP, talcum filled <b>D6</b> PP, chemically bonded fiberglass

## FLAT FAN NOZZLES

HGQ flat fan nozzles feature a 60° spray angle and their wide range of flow rates makes them the best choice in pre-treatment plants. For an easier identification and use, they are made in different colours depending on the flow rate. The material is top quality PP, chemically bonded fibreglass to offer the best stability at high temperatures and resistance to chemicals.

CODE	Capacity at different pressure values (l/min) (bar)						Colour	W g	
	0.5	0.7	1.0	1.5	2.0	3.0			
60°	<b>HGQ 1390 xx</b>	1.70	2.00	2.40	2.90	3.30	3.90	BLACK	16
	<b>HGQ 1780 xx</b>	3.18	3.77	4.50	5.52	6.37	7.80	PURPLE	
	<b>HGQ 1980 xx</b>	4.00	4.70	5.60	6.90	8.00	9.80	BROWN	
	<b>HGQ 2117 xx</b>	4.60	5.50	6.50	8.00	9.30	11.7	YELLOW	
	<b>HGQ 2135 xx</b>	5.50	6.50	7.80	9.50	11.0	13.5	GREY	
	<b>HGQ 2155 xx</b>	6.20	7.40	8.80	10.8	12.5	15.5	RED	
	<b>HGQ 2195 xx</b>	7.80	9.20	11.0	13.8	15.6	19.5	GREEN	
	<b>HGQ 2230 xx</b>	9.50	11.3	13.5	16.3	19.1	23.0	BLUE	
	<b>HGQ 2270 xx</b>	10.9	12.8	15.4	18.8	21.7	27.0	SKY BLUE	
	<b>HGQ 2337 xx</b>	13.8	16.4	19.5	24.0	27.7	33.7	WHITE	
	<b>HGQ 2410 xx</b>	16.7	19.8	23.6	29.0	33.5	41.0	PINK	

## HOLLOW CONE NOZZLES

RGN hollow cone nozzles have a 50° spray angle and offer a wide range of flow rates, all identified by a particular nozzle colour to avoid any possible confusion. The material is top quality PP, chemically bonded fibreglass to offer the best stability at high temperatures and resistance to chemicals. For these features they are widely used in pre-treatment plants.

CODE	Capacity at different pressure values (l/min) (bar)						Colour	W g	
	0.5	0.7	1.0	1.5	2.0	3.0			
50°	<b>RGN 2175 xx</b>	7.10	8.50	10.1	12.4	14.3	17.5	ROSSO	25
	<b>RGN 2215 xx</b>	8.80	10.4	12.4	15.2	17.6	21.5	BLU	
	<b>RGN 2390 xx</b>	15.9	18.8	22.5	27.6	31.8	39.0	NERO	



**RGN**  
Hollow cone nozzle

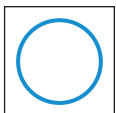
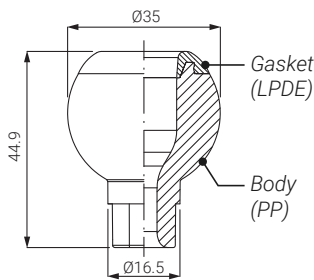

Spray section

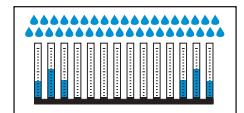

Concave distribution



### HOW TO MAKE UP THE PRODUCT CODE

Ex.: HGQ 1390 D5

**HGQ 1390 D5**

MATERIAL

- D5 - PP, talcum filled
- D6 - PP, chemically bonded fiberglass

CAPACITY

NOZZLE TYPE

- HGQ - Flat fan nozzles (60°)
- RGN - Hollow cone nozzles (50°)



## ( FLAT FAN QUICK-FIT SPOON NOZZLES ) **KS/QQ**

### FLAT FAN QUICK-FIT SPOON NOZZLES

KS flat fan quick-fit spoon nozzles produce a flat spray pattern with a 50° or 60° deflection spray angle and offer the highest possible impact for a given feed pressure, up to 60° compared to standard turbulence flat fan nozzles. The innovative design ensures the ideal efficiency for deep cleaning and their quick connection makes them easy to assemble and avoids leakage. The different flow rates are identified by their colours available for proper selection. Materials are high quality PP and chemically bonded fiberglass to keep stability at high temperatures and be chemicals-resistant. These nozzles are widely used in surface pre-treatments.

MATERIAL **D6** PP, chemically bonded fiberglass  
 TYPICAL APPLICATION Cleaning equipment used in pre-treatment for coating process

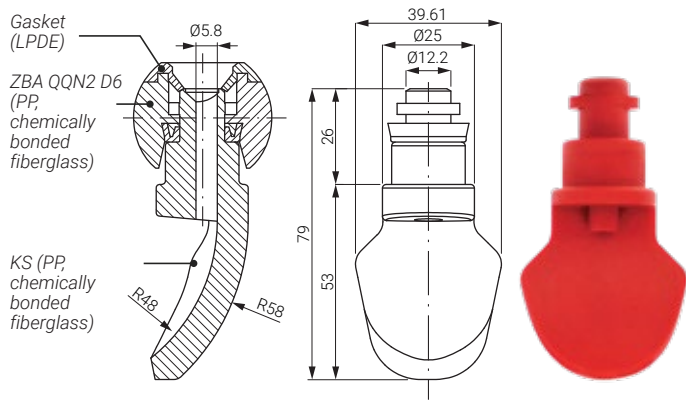

◁	CODE	Capacity at different pressure values (l/min) (bar)						Colour	W g
		0.5	0.7	1.0	1.5	2.0	3.0		
50°	<b>KSN 2155 D6QQS</b>	6.20	7.40	8.80	10.8	12.5	15.5	RED	23
	<b>KSN 2195 D6QQS</b>	7.80	9.20	11.0	13.5	15.6	19.5	GREEN	
	<b>KSQ 2230 D6QQS</b>	9.50	11.3	13.5	16.5	19.1	23.0	BLUE	
	<b>KSQ 2270 D6QQS</b>	10.9	12.8	15.4	18.8	21.7	27.0	SKY BLUE	
60°	<b>KSQ 2337 D6QQS</b>	13.9	16.4	19.6	24.0	27.7	33.7	WHITE	
	<b>KSQ 2390 D6QQS</b>	15.9	18.8	22.5	27.6	31.8	39.0	ORANGE	
	<b>KSQ 2410 D6QQS</b>	16.7	19.8	23.6	29.0	33.5	41.0	PINK	
	<b>KSQ 2433 D6QQS</b>	17.7	21.0	25.0	30.6	35.3	43.3	BROWN	



Spray section

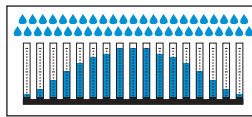

Convex distribution



## ( FLAT FAN QUICK-FIT NOZZLES ) **HT/QQ**

### FLAT FAN QUICK-FIT NOZZLES

HTQ type flat fan quick-fit nozzles feature 60° spray angle and impact force for a given feed pressure. The new design offers the ideal efficiency for cleaning, quick-fit design for ease of assembly and seal that avoids leakage. Different flow rates are distinguished by color and available for selection. The materials are high quality PP, chemically bonded fiberglass in order to remain stable in high temperature and chemical attacks. They are widely used in surface pre-treatment.

SPRAY ANGLE 60°  
 MATERIAL **D6** PP, chem. bonded fiberglass  
**B31** AISI 316L Stainless steel

TYPICAL APPLICATION Surface pre-treatment plants

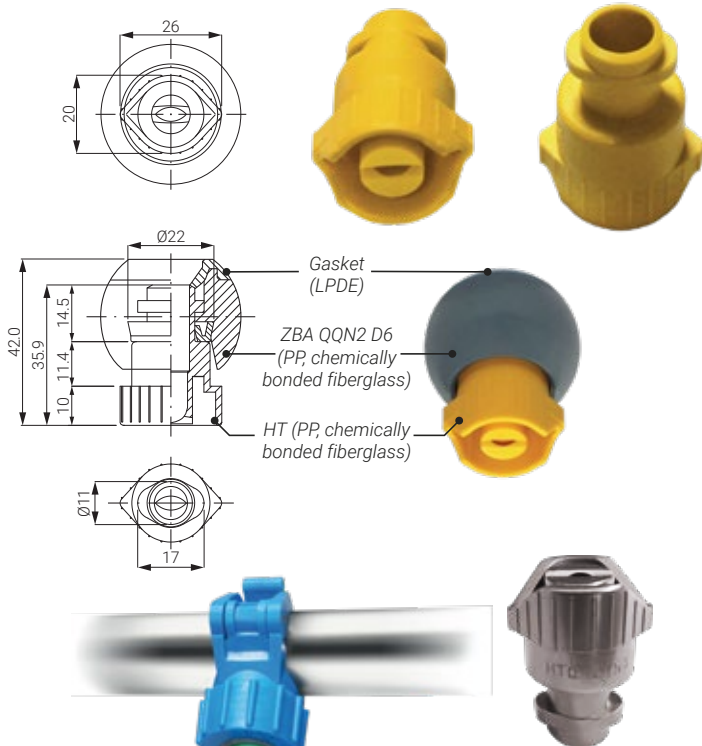
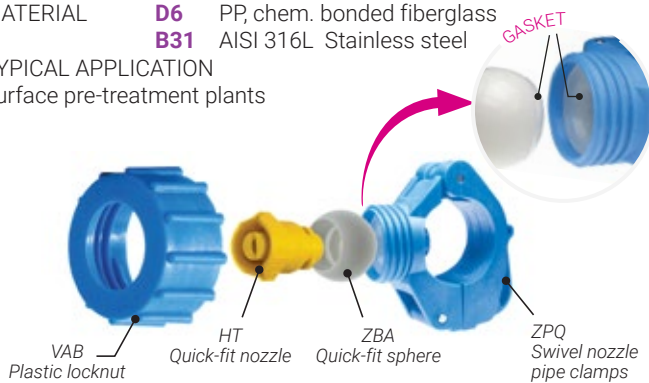

◁	CODE	Capacity at different pressure values (l/min) (bar)						Colour
		0.5	0.7	1.0	1.5	2.0	3.0	
60°	<b>HTQ 1390 xxQQS</b>	1.60	1.90	2.30	2.80	3.20	3.90	BLACK
	<b>HTQ 1590 xxQQS</b>	2.40	2.80	3.40	4.20	4.80	5.90	PURPLE
	<b>HTQ 1780 xxQQS</b>	3.20	3.80	4.50	5.50	6.40	7.80	LILAC
	<b>HTQ 2117 xxQQS</b>	4.80	5.70	6.80	8.30	9.60	11.7	YELLOW
	<b>HTQ 2153 xxQQS</b>	6.20	7.40	8.90	11.0	12.8	15.3	RED
	<b>HTQ 2195 xxQQS</b>	8.00	9.40	11.3	13.8	15.9	19.5	GREEN
	<b>HTQ 2230 xxQQS</b>	9.40	11.1	13.3	16.3	18.8	23.0	BLUE
	<b>HTQ 2274 xxQQS</b>	11.2	13.2	15.6	19.1	22.4	27.4	SKY BLUE

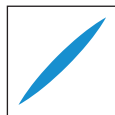

Spray section

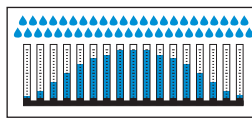

Convex distribution





# ZPG (PIPE HOLDERS)



**SINGLE SPRING**

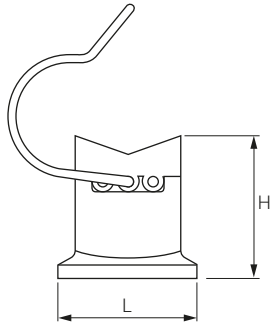

**DOUBLE SPRING**

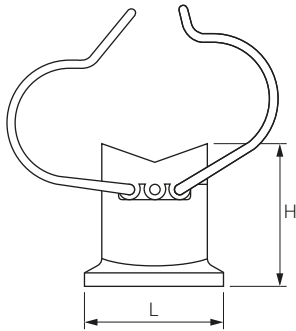

## PIPE HOLDERS

ZPG pipe holders are a user-friendly and convenient solution for fixing spray manifolds onto tunnels walls in surface treatment plants. They are easy to assemble, excellent fastening and low cost. The single spring type is suitable for plastic holder whereas the double spring version is meant for metallic pipe holders.

**TYPICAL APPLICATION** Cleaning equipment used in pre-treatment for coating process  
**PIPE SIZE** PS 3/4", 1", 1 1/4", 1 1/2", 2"  
**MATERIAL** Body **D6** PP, chemically bonded fiberglass  
 Springs **N1** AISI 302, heat treated

CODE		PS inch	D mm	H mm	L mm	CH mm	W g
Single spring	Double spring						
ZPG 1075 D6	ZPG 2075 D6	3/4"	11	53	50	17	72
ZPG 1100 D6	ZPG 2100 D6	1"					72
ZPG 1125 D6	ZPG 2125 D6	1 1/4"					90
-	ZPG 2150 D6	1 1/2"					90
-	ZPG 2200 D6	2"					110

Weight values are based on the double spring version

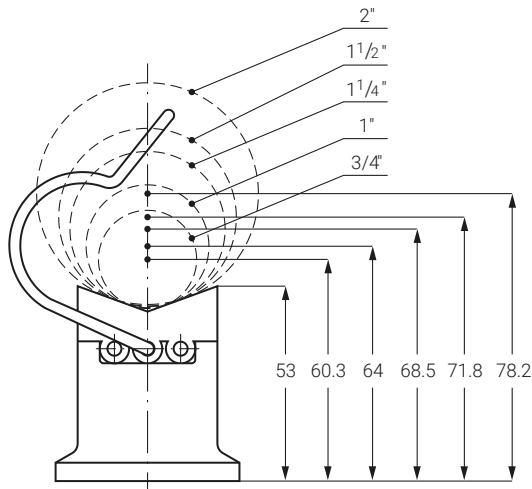
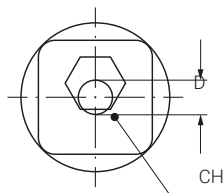

ZPG body is designed to be fastened to the tunnel wall by means of one M10 bolt with 17 mm hexagonal head.

The drawing shows the distances of the pipe central axis from the wall for different pipe sizes assembled onto the pipe holder.

**HOW TO MAKE UP THE PRODUCT CODE** Ex.: ZPG 1075 D6

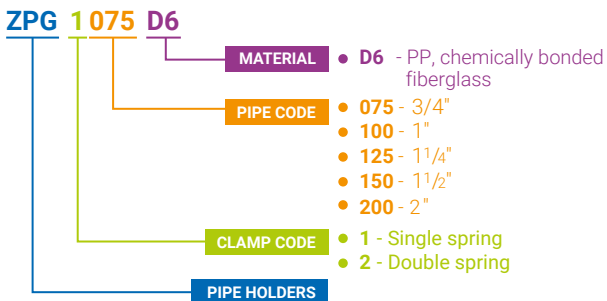

The above photo shows a top coating plant using our products.

( QUICK COUPLING JOINTS ) **ZSA**

**QUICK COUPLING JOINTS**

ZSA quick couplings for pipes find considerable applications in surface pre-treatment plants due to their operational flexibility and quick and easy maintenance. They have been designed for industrial applications, offer considerable strength and are made of high quality materials resistant to corrosion and structural stress.

THREAD SIZE	3/4", 1", 1-1/4", 1-1/2"
THREAD SPECIFICATION	BSPB
TYPICAL APPLICATIONS	Cleaning equipment used in pre-treatment for coating process Addition and release of liquids in chemical tankers
MATERIAL	Body <b>D6</b> PP, chemically bonded fiberglass <b>B3</b> AISI 316 Stainless Steel Lever <b>B31</b> AISI 316L Stainless Steel, cast <b>B35</b> AISI 316 Stainless Steel, sintered <b>D8</b> PVDF, Polyvinylidene fluoride O-ring <b>E0</b> EPDM <b>E7</b> Viton <b>E8</b> NBR

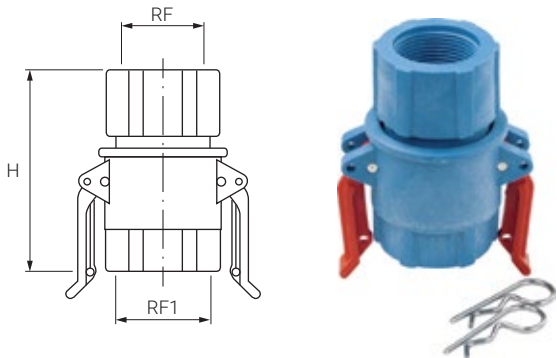

CODE	RF1 inch	RF inch	H mm	LP bar	W kg
ZSA 0075 B3xG	3/4"	3/4"	68	15	*
ZSA 0075 D6xG			85	9	*
ZSA 0100 B3xG	1"	1"	78	15	*
ZSA 0100 D6xG			93	7	*
ZSA 0125 B3xG	1 1/4"	1 1/4"	89	15	*
ZSA 0125 D6xG			113	7	*
ZSA 0150 D6xG	1 1/2"	1 1/4"	113	6	*
ZSA 0151 B3xG	1 1/2"	1 1/2"	83	15	*
ZSA 0151 D6xG			113	6	*

**HOW TO MAKE UP THE PRODUCT CODE** Ex.: ZSA 0075 B3BG

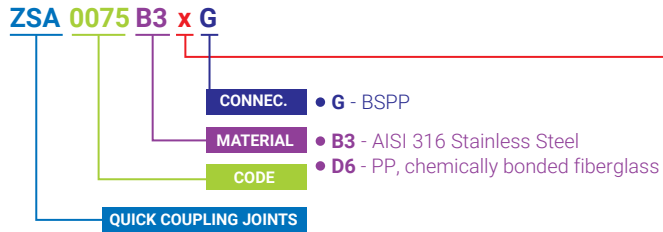

\* Weight values for different materials are given on request

X	Orientation	Lever material	O-ring	Rings
B	Fixed	AISI 316L, sint	EPDM	AISI 316
C	Fixed	PVDF	EPDM	AISI 316
D	Fixed	PVDF	VITON	AISI 316
F	Fixed	PVDF	EPDM	-
G	Fixed	PVDF	VITON	-
H	Fixed	AISI 316L, sint	VITON	AISI 316
S	Free	AISI 316L, sint	EPDM	AISI 316
R	Free	AISI 316L, microf	EPDM	AISI 316
Q	Free	AISI 316, mecc.	NBR	AISI 316
T	Free	PVDF	EPDM	AISI 316
U	Free	PVDF	VITON	AISI 316
V	Free	PVDF	EPDM	-
W	Free	PVDF	VITON	-
X	Free	AISI 316, mecc.	VITON	-
Y	Free	AISI 316L, sint	VITON	AISI 316

**QUICK COUPLING JOINTS - INSTALLMENT**

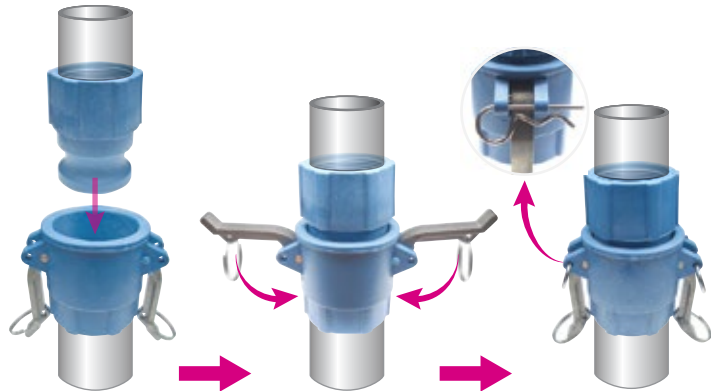

A. Join two parts of quick coupling together B. Put levers down and fasten C. Fix bolt and complete setup

**QUICK FITTING RISERS AND HEADER MANIFOLDS**

Our range of products for surface pre-treatment plants is the most complete on the market and has been developed in collaboration with the most important system manufacturers on a worldwide basis. PNR has designed most of the assembly accessories commonly adopted today in pre-treatment plants. Right figure shows the installment steps. Quick couplings and pipe holder clamps can be quickly assembled and disassembled in seconds to minimize maintenance and shut-off time.

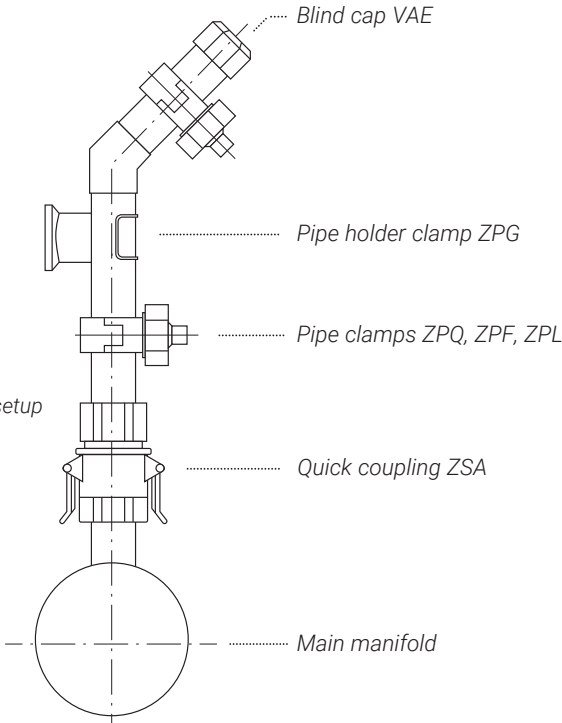

# ZRA (STANDARD SWIVEL JOINTS)



ZRA 1212 B1

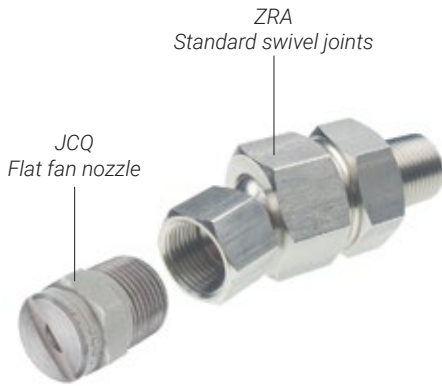
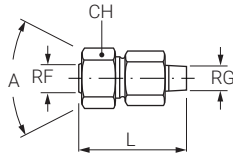

## STANDARD SWIVEL JOINTS

ZRA/ZRB/ZRC are standard swivel joints for manufacturing plants requiring product diversification. The fitting and adjustment of the joints can be done easily by tightening the hexagonal screw cap.

### TYPICAL APPLICATIONS

Cleaning equipment used in pre-treatment for coating process  
Continuous casting cooling

### INLET THREAD SIZE

1/8", 1/4", 3/8", 1/2", 3/4"

### OUTLET THREAD SIZE

1/8", 1/4", 3/8", 1/2", 3/4"

### MAX WORKING PRESSURE

**LP** 21 bar

### MATERIAL

**B1** AISI 303 Stainless Steel

**B31** AISI 316L Stainless Steel

**T1** Brass

CODE	RG inch	RF inch	L mm	A deg	CH mm	W g
ZRA 1212 xx YZ	1/8"	1/8"	38	50°	22	57
ZRA 2525 xx YZ	1/4"	1/4"	59	50°	22	75
ZRA 3838 xx YZ	3/8"	3/8"	72	50°	27	155
ZRA 5050 xx YZ	1/2"	1/2"	82	50°	27	186
ZRA 7575 xx YZ	3/4"	3/4"	92	50°	41	468

CODE	RF inch	RF inch	L mm	A deg	CH mm	W g
ZRB 1212 xx YZ	1/8"	1/8"	29	50°	22	57
ZRB 2525 xx YZ	1/4"	1/4"	49	50°	22	75
ZRB 3838 xx YZ	3/8"	3/8"	52	50°	27	155
ZRB 5050 xx YZ	1/2"	1/2"	72	50°	27	186
ZRB 7575 xx YZ	3/4"	3/4"	85	50°	32	468

CODE	RF inch	L mm	A deg	CH mm	W g
ZRC 1212 xx YZ	1/8"	32	50°	22	57
ZRC 2626 xx YZ	1/4"	67	50°	27	147
ZRC 7575 xx YZ	3/4"	92	50°	32	468

### HOW TO MAKE UP THE PRODUCT CODE

ZRx 1212 xx Y Z

- THREAD**
  - B - BSP (female), BSPT (male)
  - N - NPT
- VARIANT**
  - S - Standard (three parts)
  - R - Reduced (two parts)
- MATERIAL**
  - B1 - AISI 303 Stainless Steel
  - B31 - AISI 316L Stainless Steel
  - T1 - Brass
- INLET THREAD SIZE**
  - 12 - 1/8"
  - 25 - 1/4"
  - 38 - 3/8"
  - 50 - 1/2"
  - 75 - 3/4"
- OUTLET THREAD SIZE**
  - 12 - 1/8"
  - 25 - 1/4"
  - 38 - 3/8"
  - 50 - 1/2"
  - 75 - 3/4"

NOZZLE TYPE	INLET	OUTLET
ZRA	Male	Female
ZRB	Female	Female
ZRC	Welded	Female

ZRA

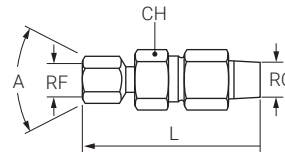

ZRB

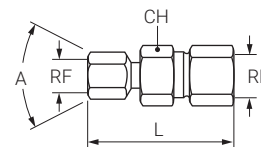

ZRC

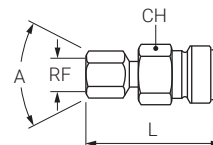

## ( TRIANGLE FLANGED SWIVEL JOINTS ) ZRP

### TRIANGLE FLANGED SWIVEL JOINTS

ZRP triangular flanged swivel joints have a robust metallic structure, are easy to fit and adjust and are widely used in manufacturing plants requiring product diversification.

TYPICAL APPLICATIONS Cleaning equipment used in pre-treatment for coating process, continuous casting cooling

THREAD SPECIFICATION BSP, NPT  
 INLET THREAD SIZE 1/8", 1/4", 3/8"  
 OUTLET THREAD SIZE 1/8", 1/4", 3/8"  
 MAX WORKING PRESSURE LP 15 bar

CODE	RG inch	RF inch	L mm	B mm	L1 mm	A deg	W g
ZRP 1212 xx	1/8"	1/8"	30	40	35	50°	65
ZRP 2512 xx	1/4"	1/8"	32				92
ZRP 2525 xx	1/4"	1/4"	40	50	45	60°	140
ZRP 2538 xx	1/4"	3/8"	40				150
ZRP 3825 xx	3/8"	1/4"	40				150
ZRP 3838 xx	3/8"	3/8"	40				150

HOW TO MAKE UP THE PRODUCT CODE Ex.: ZRP 1212 B31

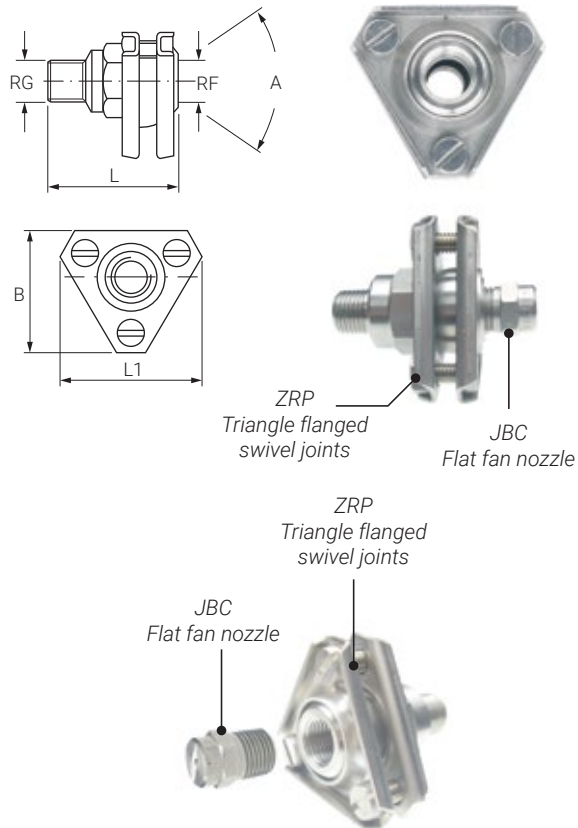
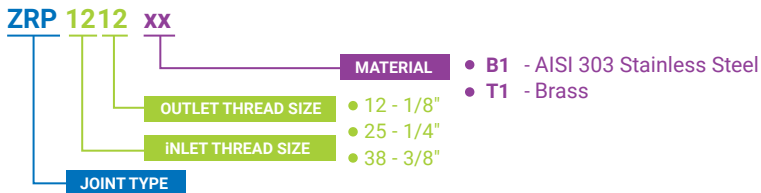

### LARGE CAPACITY SWIVEL JOINTS

ZRQ series swivel joints are suitable for operating environments requiring large capacities and product diversification. Once set, they can be easily fitted and adjusted.

TYPICAL APPLICATIONS Cleaning equipment used in pre-treatment for coating process, continuous casting cooling

THREAD SPECIFICATION BSP, NPT  
 INLET/OUTLET THREAD SIZE 1", 1 1/4", 1 1/2", 2", 2 1/2"  
 MAX WORKING PRESSURE LP 9 bar  
 MATERIAL B1 AISI 303 Stainless Steel, B31 AISI 316L Stainless Steel, T1 Brass

CODE	RG inch	RG1 inch	RF inch	L mm	D mm	A deg	W kg
ZRQ 8080 xx	1"	-	1"	89	92	40°	1.8
ZRQ 8282 xx	1 1/4"	-	1 1/4"	130			2.1
ZRQ 8482 xx	1 1/2"	-	1 1/4"	133			2.4
ZRR 8282 xx	1 1/4"	1 1/4"	-	130	92	40°	2.2
ZRR 8284 xx	1 1/2"	1 1/4"	-	130			2.2
ZRR 8484 xx	1 1/2"	1 1/2"	-	130			2.4
ZRR 8686 xx	2"	2 1/2"	-	203	158	40°	8.0
ZRR 8888 xx	2 1/2"	2 1/2"	-	229			8.8

HOW TO MAKE UP THE PRODUCT CODE Ex.: ZRQ 8080 B31

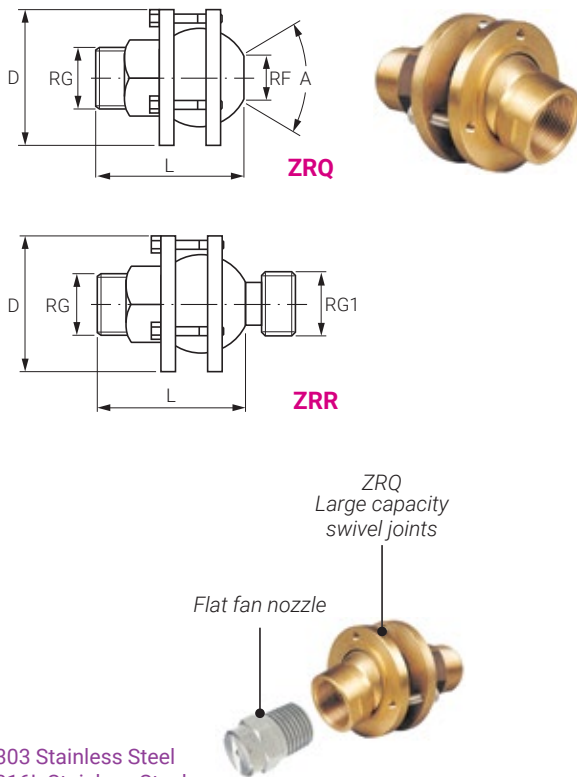
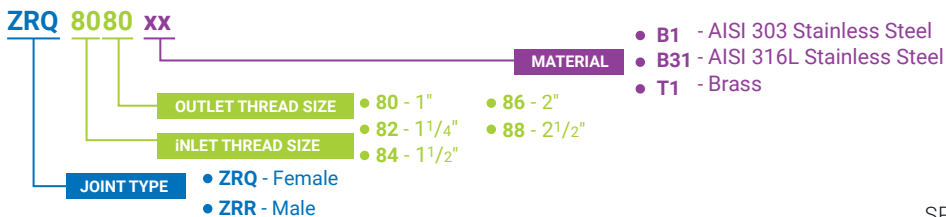

# GENERAL INFORMATION

## DISCLAIMER

Our products are manufactured with the best care and according to the latest developments of the technology available. However we cannot assure that every one of our products is perfectly fit for every specific application. The information in this catalogue is provided "as seen" and so we offer no warranty of any kind with respect to the subject matter or accuracy of the information contained herein. This publication may include technical inaccuracies or typographical errors and changes may be periodically made to the information herein without prior notice.

As a result of continuous product improvement our documentation is regularly updated: please visit our website [www.pnr.eu](http://www.pnr.eu) to be always updated.

## PRODUCT WARRANTY

PNR products will be replaced or repaired at the option of PNR and free of charges if found defective in manufacturing, labelling and packaging. The above conditions will apply if notice of defects is received by PNR within 30 days from date of product installations or one year from date of shipment. The cost of above said replacement or repair shall be the exclusive remedy for any breach of any warranty, and PNR shall not be held liable for any damage due to personal injuries or commercial losses coming from product malfunction.

It is self-understood that no warranty may apply in case our products have been operated under nonacceptable conditions, like for example (but not limited to):

- Operation at pressures exceeding those shown in catalogue performance table
- Operation with or exposure to liquids containing abrasive particles
- Operation with or exposure to liquids producing a chemical attack on the nozzle material
- Mechanical damages to nozzle orifices, nozzle spray edge or body due to careless handling or assembling.

In all above cases, the customer must accept a nozzle life reduction below life expected, or performance parameters below the values in the catalogue.

The guarantee may be exercised as follows:

1. By sending a precautionary report to PNR on the detected damages. This report can also be sent by email to this address: [quality@pnr.it](mailto:quality@pnr.it)
2. If PNR ascertains that the manufacturing faults are actually subject to the warranty, the product shall have be returned to the manufacturer in its original packaging prior request of authorization to the manufacturer and receipt of manufacturer's written authorization.
3. The rejected goods shall have be returned by the means that PNR will communicate to the customer and the transportation costs of returned merchandise will be entirely borne by the manufacturer.

## COPYRIGHT

All the contents (texts, images, graphics, layouts, etc.) of this document are property of PNR Italia Srl. Any redistribution or reproduction of part or all of the contents in any form is prohibited.



## NOZZLE IDENTIFICATION CODES

As any other industrial product, spray nozzles need to be precisely identified by means of a code in order to avoid mistakes.

PNR coding system was created bearing in mind the following requirements:

- Codes must be easily processed by a computer, in ascending order.
- Codes must be self-explaining with no need of additional descriptions.
- Codes must give the basic nozzle specifications so to be easily found in the catalogue.

Therefore, we have created our coding system as described here below:

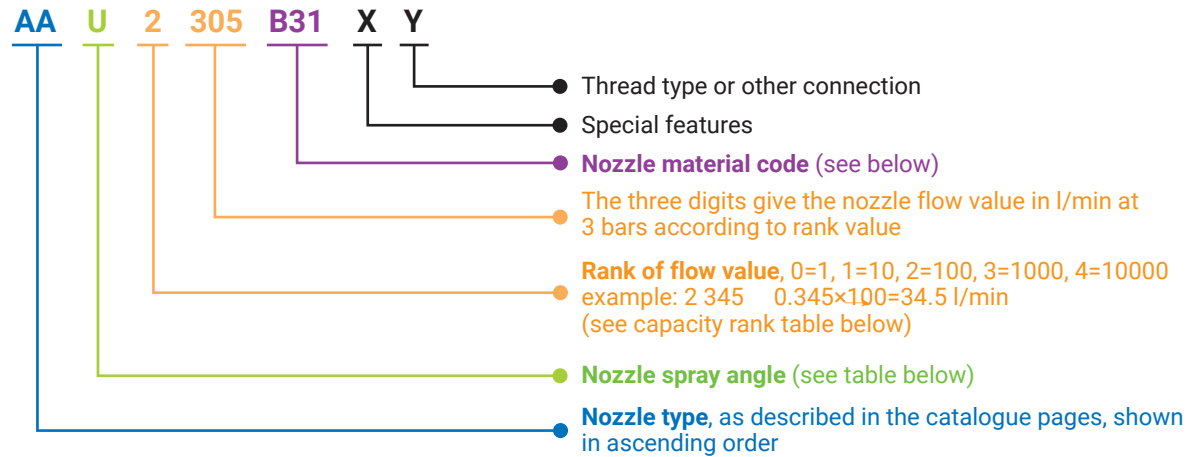

## CAPACITY RANK

Nozzles nominal flow rate, measured at 3.0 bar are highlighted on a yellow background in the catalogue tables. Flow values were calculated at different

Rank	Flow digits	Actual flow (l/min)
0	0 490	0.49
1	1 490	4.90
2	2 490	49.0
3	3 490	490
4	4 490	4900

## SOME SPRAY ANGLE CODES (degrees)

These codes serve as an indication only. Based on different types of nozzles, their significance can be occasionally different.

Code	Spray angle	Code	Spray angle	Code	Spray angle
A	0°	L	40°	T	80°
B	15°	M	45°	U	90°
C	20°	N	50°	V	95°
D	25°	Q	60°	J	110°
F	30°	R	65°	W	120°
H	35°	S	75°	Y	130°
		Z	180°		

## NOZZLE MATERIAL CODES

<b>A1</b>	Carbon steel	<b>D4</b>	Nylon, Glassfibers reinforced	<b>G1</b>	Cast iron
<b>A2</b>	High speed steel	<b>D5</b>	Talcum filled Polypropylene	<b>H1</b>	Gr.2 titanium
<b>A8</b>	Zinc coated steel	<b>D6</b>	Glassfibre reinforced PP	<b>L1</b>	Monel 400
<b>A9</b>	Nickel coated steel	<b>D7</b>	High density polyethylene	<b>L2</b>	Incolloy 825
<b>B1</b>	AISI 303 stainless steel	<b>D8</b>	Polyvinylidene fluoride (PVDF)	<b>L61</b>	Hastelloy C22
<b>B2</b>	AISI 304L stainless steel	<b>D82</b>	PVDF, Injection molded	<b>L8</b>	Hastelloy C276
<b>B3</b>	AISI 316 stainless steel	<b>E0</b>	EPDM	<b>N1</b>	AISI 302 stainless steel
<b>B31</b>	AISI 316L stainless steel	<b>E1</b>	Polytetrafluoroethylene (PTFE)	<b>T1</b>	Brass
<b>B35</b>	AISI 316L stainless steel (sintered)	<b>E2</b>	PTFE (15% glassfibers)	<b>T2</b>	Brass, chrome plated
<b>C2</b>	AISI 416 stainless steel, hardened	<b>E3</b>	Polyoxymethylene (POM)	<b>T3</b>	Copper
<b>C3</b>	AISI H13 steel, hardened	<b>E31</b>	Polyoxymethylene - molded (POM)	<b>T33</b>	Copper + AISI 316
<b>C7</b>	AISI 316Ti stainless steel	<b>E6</b>	LUCITE ® (PMMA)	<b>T5</b>	Bronze
<b>D1</b>	Polyvinylchloride (PVC)	<b>E7</b>	Viton	<b>T8</b>	Brass, nickel plated
<b>D2</b>	Polypropylene (PP)	<b>E8</b>	Synthetic rubber (NBR)	<b>T81</b>	Brass, electroless nickel plated
<b>D21</b>	Molded polypropylene (PP)	<b>F30</b>	Ruby insert, AISI 303 body	<b>V1</b>	Aluminum
<b>D3</b>	Polyamide (PA)	<b>F31</b>	Ruby insert, AISI 316 body	<b>V7</b>	Aluminum, electroless n. plated
		<b>F5</b>	Ceramic		

LENGTH CONVERSION TABLE					
μm	mm	cm	m	inch	ft
1	1x10 <sup>-3</sup>	1x10 <sup>-4</sup>	1x10 <sup>-6</sup>	3.94x10 <sup>-5</sup>	3.28x10 <sup>-6</sup>
1x10 <sup>3</sup>	1	0.1	1x10 <sup>-3</sup>	3.94x10 <sup>-2</sup>	3.28x10 <sup>-3</sup>
1x10 <sup>4</sup>	10	1	1x10 <sup>-2</sup>	3.94x10 <sup>-1</sup>	3.28x10 <sup>-2</sup>
1x10 <sup>7</sup>	1x10 <sup>3</sup>	100	1	39.4	3.28
2.54x10 <sup>4</sup>	25.4	2.54	2.54x10 <sup>-2</sup>	1	8.33x10 <sup>-2</sup>
3.05x10 <sup>5</sup>	3.05x10 <sup>2</sup>	30.5	3.05x10 <sup>-1</sup>	12	1

AREA CONVERSION TABLE			
cm <sup>2</sup>	m <sup>2</sup>	inch <sup>2</sup>	ft <sup>2</sup>
1	1x10 <sup>-4</sup>	0.155	1.08x10 <sup>-3</sup>
1x10 <sup>4</sup>	1	1.55x10 <sup>3</sup>	10.8
6.45	6.45x10 <sup>-4</sup>	1	6.94x10 <sup>-3</sup>
9.30x10 <sup>2</sup>	9.30x10 <sup>-2</sup>	1.44x10 <sup>2</sup>	1

VOLUME CONVERSION TABLE				
cm <sup>3</sup>	Liter	m <sup>3</sup>	ft <sup>3</sup>	US Gallons
1	1x10 <sup>-3</sup>	1x10 <sup>-6</sup>	3.53x10 <sup>-5</sup>	2.64x10 <sup>-4</sup>
1000	1	1x10 <sup>-3</sup>	3.53x10 <sup>-2</sup>	0.264
1x10 <sup>6</sup>	1000	1	353	264
2.83x10 <sup>4</sup>	28.3	2.83x10 <sup>-2</sup>	1	0.749
3.79x10 <sup>3</sup>	3.79	3.79x10 <sup>-3</sup>	1.34	1

PRESSURE CONVERSION TABLE						
MPa	KPa	Bar	Kg/cm <sup>2</sup>	P.S.I	atm	mHg
1	1000	10	10.2	145	9.87	7.5
0.001	1	0.01	0.011	0.145	9.87x10 <sup>-3</sup>	7.5x10 <sup>-1</sup>
0.1	100	1	1.02	14.5	0.987	0.75
0.09807	98.07	0.981	1	14.22	0.968	0.736
0.00689	6.89	0.069	0.07	1	0.068	0.052
0.101	1.01x10 <sup>2</sup>	1.013	1.033	14.7	1	0.76
0.133	1.33x10 <sup>2</sup>	1.33	1.36	19.3	1.32	1

LIQUID PIPE TABLE	
Inlet pressure: 3 bar	
DIAMETER (inch)	MAX CAPACITY VALUES (l/min)
1/8"	11.20
1/4"	44.70
3/8"	100.80
1/2"	179.30
3/4"	402.00
1"	716.30
1 1/4"	1121.84
1 1/2"	1610.75
2"	2865.24

FLOW RATE AND PIPE DIAMETER				
Diameter		Steel pipe		Length 10m Capacity value at 0.1~0.3kg/cm <sup>2</sup> pressure loss
A	B	Inner diameter	Outer diameter	
6A	1/8B	6.5	10.5	1.3 ~ 2.2
8A	1/4B	9.2	13.8	3 ~ 5.2
10A	3/8B	12.7	17.3	7 ~ 12
15A	1/2B	16.1	21.7	12 ~ 21
20A	3/4B	21.6	27.2	22 ~ 38
25A	1B	27.6	34.0	38 ~ 65
32A	1 1/4B	35.7	42.7	70 ~ 120
40A	1 1/2B	41.6	48.6	120 ~ 210
50A	2B	52.9	60.5	215 ~ 370
65A	2 1/2B	67.9	76.3	410 ~ 700
80A	3B	80.7	89.1	680 ~ 1200
100A	4B	105.3	114.3	1200 ~ 2100
125A	5B	130.8	139.8	2100 ~ 3600
150A	6B	155.2	165.2	3300 ~ 5700

FLOW RATE UNIT CONVERSION TABLE					
l/min	m <sup>3</sup> /min	m <sup>3</sup> /hour	Inch <sup>3</sup> /hour	ft <sup>3</sup> /hour	US Gallons / min
1	0.001	0.06	3.66x10 <sup>3</sup>	2.12	0.264
1000	1	60	3.66x10 <sup>6</sup>	2.12x10 <sup>3</sup>	264
16.67	0.017	1	6.1x10 <sup>4</sup>	35.3	4.40
2.73x10 <sup>-4</sup>	2.7x10 <sup>-7</sup>	1.64x10 <sup>-5</sup>	1	5.79x10 <sup>-4</sup>	7.22x10 <sup>-6</sup>
0.472	4.72x10 <sup>-4</sup>	0.028	1.728	1	0.125
3.79	0.004	0.227	1.39x10 <sup>4</sup>	8.02	1

AIR PIPE TABLE								
Pipe size	1/8"	1/4"	3/8"	1/2"	3/4"	1"	1 1/4"	1 1/2"
Pressure lost for 10m (bar)	1.25	0.733	0.56	0.44	0.287	0.214	0.138	0.108
INLET PRESSURE (bar)	MAX CAPACITY VALUES (NL/min)							
1.5	163	314	668	1076	1885	3150	4960	6630
2.0	179	344	730	1180	2060	3450	5430	7280
3.0	206	395	840	1360	2375	3900	6300	8400
4.0	230	422	940	1520	2660	4450	7000	9360
5.0	252	485	1030	1660	2920	4875	7700	10250
6.0	272	523	1110	1800	3140	5250	8300	11050
7.0	292	558	1185	1920	3350	5620	8870	11800

## ABBREVIATIONS

CODE	NAME	UNIT	CODE	NAME	UNIT	CODE	NAME	UNIT
<b>CL</b>	Jet deflection angle	deg	<b>DIA</b>	Outside diameter	mm	<b>NR</b>	Number of orifices	--
<b>D</b>	Conventional orifice diameter	mm	<b>DU</b>	Liquid outer diameter	mm	<b>QC</b>	Quick-fit connection	--
<b>D1</b>	Smallest free inside diameter	mm	<b>E</b>	Inlet diameter	mm	<b>RF</b>	Female BSP straight thread	inch
<b>D2</b>	Liquid inlet diameter	mm	<b>EF</b>	Flange diameter	mm	<b>RG</b>	Male BSPT tapered thread	inch
<b>D3</b>	Liquid outlet diameter	mm	<b>FF</b>	Flange outer diameter	mm	<b>SQ</b>	Square bar size	mm
<b>DE</b>	Liquid inlet diameter	mm	<b>G</b>	Flange center-hole diameter	mm	<b>UF</b>	Outlet diameter	inch
<b>DF</b>	Flange size	inch	<b>H,H1,H2</b>	Height	mm	<b>WS</b>	Wrench size (female)	mm
<b>DN</b>	Flange nominal size	mm	<b>L,L1</b>	Length	mm	<b>WS1</b>	Wrench size (female)	mm

## SPRAY ANGLE AND DISTANCES

 Spray angle	SPRAY DISTANCE (mm)													
	50	100	150	200	250	300	400	500	600	700	800	900	1000	1500
	THEORETICAL COVERAGE AT VARIOUS DISTANCES FROM THE NOZZLE (mm)													
5°	4.4	8.7	13.1	17.5	21.8	26.2	34.9	43.7	52.4	61.1	69.9	78.6	87.3	131.0
10°	8.7	17.5	26.2	35.0	43.7	52.5	70.0	87.5	105.0	122.0	140.0	158.0	175.0	262.0
15°	13.2	26.3	39.5	52.7	65.8	79.0	105.0	132.0	158.0	184.0	211.0	237.0	263.0	395.0
20°	17.6	35.3	52.9	70.5	88.2	106.0	141.0	176.0	212.0	247.0	282.0	317.0	353.0	529.0
25°	22.2	44.3	66.5	88.7	111.0	133.0	177.0	222.0	266.0	310.0	355.0	399.0	443.0	665.0
30°	26.8	53.6	80.4	107.0	134.0	161.0	214.0	268.0	322.0	375.0	429.0	482.0	536.0	804.0
35°	31.5	63.1	94.6	126.0	158.0	189.0	252.0	315.0	378.0	441.0	504.0	568.0	631.0	946.0
40°	36.4	72.8	109.0	146.0	182.0	218.0	291.0	364.0	437.0	510.0	582.0	655.0	728.0	1092.0
45°	41.4	82.8	124.0	166.0	207.0	249.0	331.0	414.0	497.0	580.0	663.0	746.0	828.0	1243.0
50°	46.6	93.3	140.0	187.0	233.0	280.0	373.0	466.0	560.0	653.0	746.0	839.0	933.0	1399.0
55°	52.1	104.0	156.0	208.0	260.0	312.0	416.0	521.0	625.0	729.0	833.0	937.0	1041.0	1562.0
60°	57.7	115.0	173.0	231.0	289.0	346.0	462.0	577.0	693.0	808.0	924.0	1039.0	1155.0	1732.0
65°	63.7	127.0	191.0	255.0	319.0	382.0	510.0	637.0	764.0	892.0	1019.0	1147.0	1274.0	1911.0
70°	70.0	140.0	210.0	280.0	350.0	420.0	560.0	700.0	840.0	980.0	1120.0	1260.0	1400.0	2101.0
75°	76.7	153.0	230.0	307.0	384.0	460.0	614.0	767.0	921.0	1074.0	1228.0	1381.0	1535.0	2302.0
80°	83.9	168.0	252.0	336.0	420.0	503.0	671.0	839.0	1007.0	1175.0	1343.0	1510.0	1678.0	2517.0
85°	91.6	183.0	275.0	367.0	458.0	550.0	733.0	916.0	1100.0	1283.0	1466.0	1649.0	1833.0	2749.0
90°	100.0	200.0	300.0	400.0	500.0	600.0	800.0	1000.0	1200.0	1400.0	1600.0	1800.0	2000.0	3000.0
95°	109.0	218.0	327.0	437.0	546.0	655.0	873.0	1091.0	1310.0	1528.0	1746.0	1964.0	2183.0	3274.0
100°	119.0	238.0	358.0	477.0	596.0	715.0	953.0	1192.0	1430.0	1668.0	1907.0	2145.0	2384.0	3575.0
110°	143.0	286.0	428.0	571.0	714.0	867.0	1143.0	1430.0	1714.0	1999.0	2285.0	2571.0	2856.0	
115°	157.0	314.0	471.0	628.0	785.0	942.0	1256.0	1570.0	1884.0	2197.0	2511.0	2825.0	3139.0	
120°	173.0	346.0	520.0	693.0	866.0	1039.0	1386.0	1732.0	2078.0	2425.0	2771.0	3117.0	3464.0	
130°	214.0	429.0	643.0	858.0	1072.0	1287.0	1716.0	2145.0	2573.0	3002.0	3431.0	3860.0		
140°	275.0	549.0	824.0	1099.0	1374.0	1648.0	2198.0	2747.0	3297.0	3846.0				
150°	373.0	747.0	1120.0	1493.0	1866.0	2240.0	2986.0	3733.0						
160°	567.0	1134.0	1702.0	2269.0	2837.0	3403.0								
170°	1143.0	2285.0	3429.0											





PNR ITALIA HA CERTIFICATO  
IL SUO SISTEMA DI QUALITÀ CON DNV  
SECONDO LE NORME ISO 9001/2015

**COMPANY WITH  
QUALITY SYSTEM  
CERTIFIED BY DNV GL** **ISO 9001:2015**



# A GLOBAL PRESENCE ALL OVER THE WORLD.

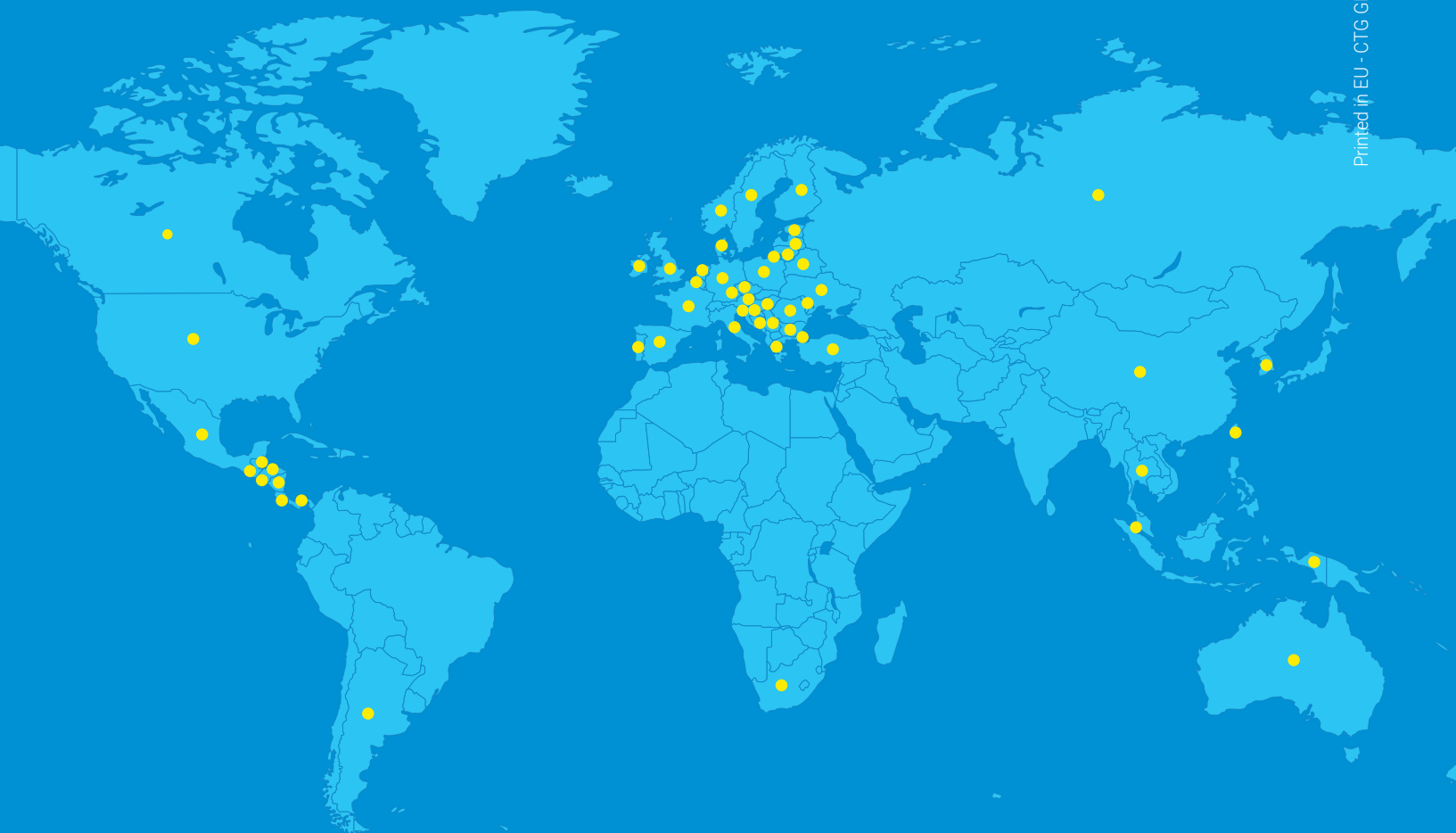

Printed in EU - CTG GEN EN 22.01 - ©PNR Italia, all rights reserved



## HEADQUARTERS:

Via Gandini 2, 27058 Voghera (PV) ITALY

☎ Phone +39 0383 344 61    ✉ Email [info@pnr.it](mailto:info@pnr.it)

For more info, visit [www.pnr.eu](http://www.pnr.eu)

