

## FULL CONE NOZZLES

There are two types of full cone nozzles: turbulence nozzles and impact nozzles, distinguishable by their different spray patterns.



**Turbulence nozzles** use vanes to produce a high-speed rotation and pressurize the liquid flow inside a turbulence chamber. Liquids are atomized by the centrifugal force that produces a solid stream jet with a full cone spray pattern.



**Impact nozzles** work on the impact principle. Liquids hit their spiral profile, atomize and produce large spray flows with full-cone patterns and desired spray angle. They have no vanes and are virtually clog-free.



To meet the needs of different operating environments, PNR developed a series of vanes, each one with its own technical features. See here below.

## VANE



**SLOTTED VANE**

**Slotted vane**, so called for its spray section with 6 flows slots on its edge portion and one in the center.

These vanes produce high-speed rotation of pressurized liquids that flow into turbulence chambers where they are atomized. Slotted vanes provide an excellent atomization in a short time. Effective for cost-saving and in case of limited space.



**DISC VANE**

Innovative design and precise machining, its smooth surface reduces pressure loss and avoids turbulence. It uses 6 peripheral passages to create a swirling motion of the liquid inside the spray chamber.

A set of superficial millings on the lower side of the disc act as a brake on the liquid rotation at the centre creating a full cone jet with an even distribution and finely atomized droplets. No central hole to avoid clogging.



**X - VANE**

**X vanes** are widely used, mainly in steelworks. Their simple design is based on two sloping flat surfaces which induce a rotation of the liquid going through the nozzle, and two small slots on each flat part to produce a full-cone spray pattern. All vanes are secured inside the nozzle body to prevent their moving in case of size changes due to high temperatures or sudden vacuum conditions in the feed pipe.



**S - TYPE VANE**

**S-type vanes** provide a large free passage of liquids through the nozzle, with nearly the same diameter of a spray tip. Therefore they offer the widest possible passage and the highest resistance to clogging among all full-cone spray nozzles with internal vane.



**SPIRAL VANE**

**Spiral vane** is specific design of spiral full cone nozzles. Liquids hit spiral vane then atomize and extend to the desired spray angle. The specific design greatly increases liquids inlet and outlet diameter. Any foreign matters entering could come out. It avoids clogging and provides larger capacity with the same thread size.

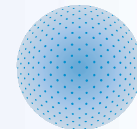

**FULL CONE**  
Round spray

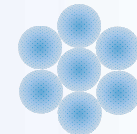

**FULL CONE**  
Cluster spray

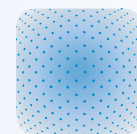

**FULL CONE**  
Square pattern

## ACCURATE SPRAYS OVERLAPPING

When full and hollow cone nozzles are used simultaneously, it's vital that they cover a uniform spray volume. In general there are two methods to achieve accurate nozzles settings: matrix configuration and offset configuration. See here below.

### Matrix configuration

- O** - width of overlapping area
- D** - diameter of spray range
- H** - nozzle distance to the object being sprayed
- P** - nozzle spacing
- θ** - spray angle

$$\text{Nozzle spacing}(P) = \frac{D}{\sqrt{2}}$$

$$\text{Overlap}(O) = D - P$$

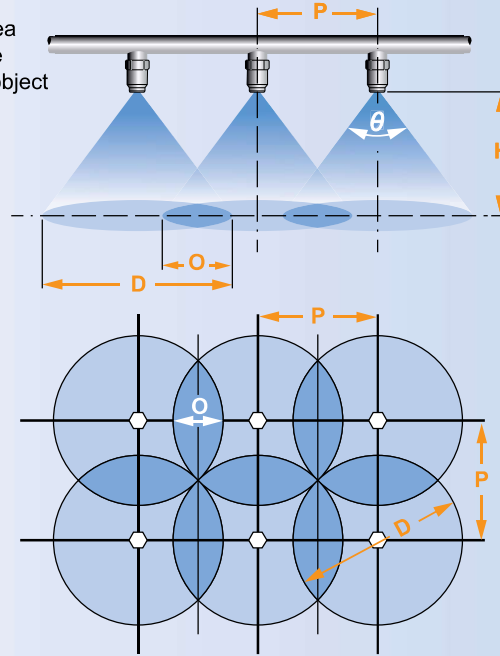

### Offset configuration

- O** - width of overlapping area
- D** - diameter of spray range
- H** - nozzle distance to the object being sprayed
- P** - nozzle spacing
- θ** - spray angle

$$\text{Nozzle spacing}(P_1) = \frac{D}{2} \times \sqrt{3}$$

$$\text{Nozzle spacing}(P_2) = \frac{3}{4}D$$

$$\text{Overlap}(O) = D - P_1$$

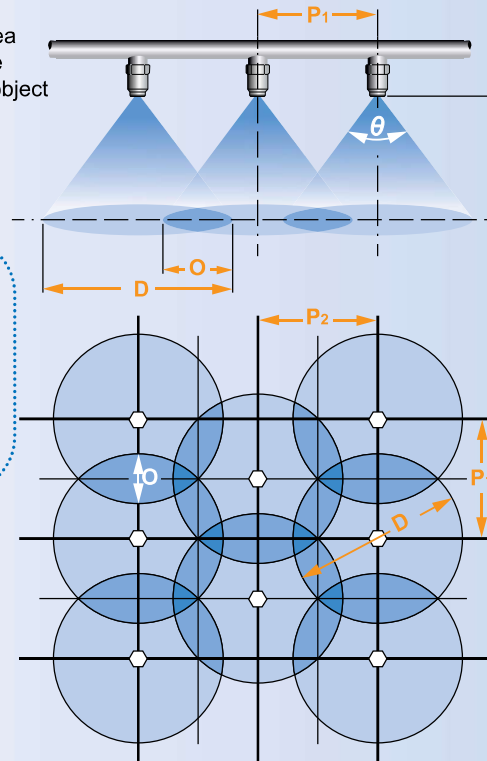

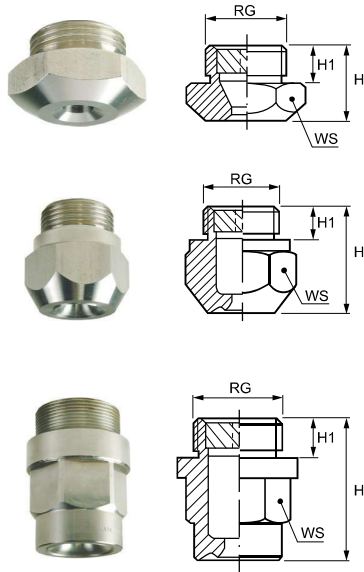

### SLOTTED VANE

AA series full cone nozzles are made of body and slotted vane, for an even spray distribution. Their design allows them to be 35% shorter than other full cone nozzles. They are used in operating environments with a restricted space available and are cost-effective for the lower material quantity.

#### Typical applications

**Washing:** exhaust scrubbers washing, vehicle parts and gravel washing

**Cooling:** high-temperature cooling, vehicle parts cooling, tank cooling

**Other applications:** spray of chemicals, sea water desalination

#### Thread size: BSP, NPT (optional)

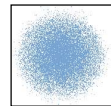

Spray section

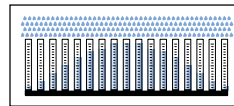

Convex distribution



Code	RG inch	D mm	D1 mm	Capacity at different pressure values								H mm	H1 mm	WS mm	
				0.5	0.7	1.0	2.0	3.0	5.0	7.0	10				
90°	AAU 2305 xx	3/4"	6.1	3.0	12.5	14.7	17.6	24.9	30.5	39.4	46.6	55.7	22	10	32
	AAU 2385 xx		6.7	3.0	15.7	18.6	22.2	31.4	38.5	49.7	58.8	70.3			
	AAU 2490 xx		7.8	4.0	20.0	23.7	28.3	40.0	49.0	63.3	74.8	89.5			
	AAU 2610 xx	1"	9.0	4.0	24.9	29.5	35.2	49.8	61.0	78.7	93.2	111	27	12	40
	AAU 2780 xx		10.5	5.0	31.8	37.7	45.0	63.7	78.0	101	119	142			
	AAU 3123 xx	1 1/4"	12.5	6.0	50.2	59.4	71.0	100	123	159	188	225	30	14	50
	AAU 3194 xx	1 1/2"	16.0	6.0	79.2	93.7	112	158	194	250	296	354	35	16	60
	AAU 3310 xx	2"	20.0	7.0	127	150	179	253	310	400	474	566	45	18	75
	AAU 3386 xx		23.0	9.0	158	186	223	315	386	498	590	705			
	AAU 3490 xx	2 1/2"	25.0	12.0	200	237	283	400	490	633	748	895	52	22	90
AAU 3610 xx		28.5	13.0	249	295	352	498	610	788	932	1114				
AAU 3775 xx	3"	32.0	16.0	316	374	447	633	775	1001	1184	1415	60	24	110	
120°	AAW 2490 xx	3/4"	7.9	3.0	20.0	23.7	28.3	40.0	49.0	63.3	74.8	89.5	38	11	32
	AAW 2780 xx	1"	13.7	6.0	31.8	37.7	45.0	63.7	78.0	101	119	142	47	15	40
	AAW 3123 xx	1 1/4"	12.7	6.0	50.2	59.4	71.0	100	123	159	188	225	62	19	50
	AAW 3194 xx	1 1/2"	16.0	6.0	79.2	93.7	112	158	194	250	296	354	77	21	50
	AAW 3310 xx	2"	20.0	10.0	127	150	179	253	310	400	474	566	99	24	60
	AAW 3386 xx		22.7	10.0	158	186	223	315	386	498	590	705			
	AAW 3490 xx	2 1/2"	25.5	12.0	200	237	283	400	490	633	748	895	123	27	75
	AAW 3610 xx		30.0	13.0	249	295	352	498	610	788	932	1114			
AAW 3775 xx	3"	32.0	14.0	316	374	447	633	775	1001	1184	1415	150	30	85	



Slotted disc vane

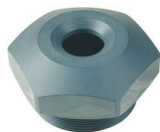

AA nozzles design is ideally suited for plastic materials.

Slotted vane, so called for its spray section with 6 flows slots on its edge portion and one in the centre.

These vanes produce high-speed rotation of pressurized liquids that flow into turbulence chambers where they are atomized. Slotted vanes provide an excellent atomization in a short time. Effective for cost-saving and in case of limited space.

Material	3/4"	1"	1 1/4"	1 1/2"	2"	2 1/2"	3"
B31 - AISI 316L					•	•	•
T1 - Brass	•						
D1 - PVC	•	•	•	•	•	•	•

#### HOW TO MAKE UP THE NOZZLE CODE

EX.: AAU 2305 B31

AA U 2305 xx



#### MATERIAL

• B31 - AISI 316L Stainless steel

• D1 - PVC

• T1 - BRASS

○ B1 - AISI 303 Stainless steel (optional)

○ D2 - PP (optional)

○ E1 - PTFE (optional)



**SLOTTED VANE**

AE type nozzles are designed to deliver large and very large capacity values from 384 l/min to 3842 l/min at 0.5 bar.

The carefully designed slotted vane offers uniform spray distribution and perfect performance even with very low inlet pressure values. Compared to other large nozzles, the upper flange reduces the length of nozzles and offers fast and safe ways to install.

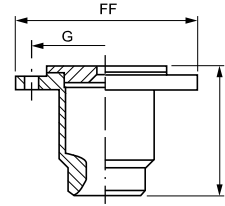

FULL CONE NOZZLES



■ **Flange specification**  
DIN Standard  
JIS Standard (optional)

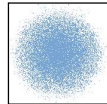

Spray section

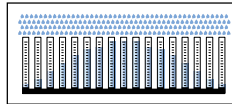

Convex distribution

Code	DN mm	D mm	D1 mm	Capacity at different pressure values (l/min)								FF mm	G mm	H mm	
				0.25	0.35	0.5	0.7	1.0	2.0	3.0	5.0				
90°	<b>AEU 3940 xx</b>	80	37.0	12.0	271	321	384	454	543	768	940	1214	200	160	140
	<b>AEU 4118 xx</b>		39.0	14.0	341	403	482	570	681	963	1180	1523			
	<b>AEU 4147 xx</b>	100	43.0	13.0	424	502	600	710	849	1200	1470	1898	220	180	156
	<b>AEU 4188 xx</b>	125	53.0	16.0	543	642	768	908	1085	1535	1880	2427	250	210	177
	<b>AEU 4235 xx</b>		56.0	16.0	678	803	959	1135	1357	1919	2350	3034			
	<b>AEU 4294 xx</b>	150	59.0	21.0	849	1004	1200	1420	1697	2400	2940	3796	285	240	188
	<b>AEU 4370 xx</b>		66.0	24.0	1068	1264	1511	1787	2136	3021	3700	4777			
	<b>AEU 4470 xx</b>	200	72.0	28.0	1357	1605	1919	2270	2714	3838	4700	6068	340	295	250
	<b>AEU 4588 xx</b>		81.0	32.0	1697	2008	2400	2840	3395	4801	5880	7591			
	<b>AEU 4741 xx</b>	250	88.0	39.0	2139	2531	3025	3579	4278	6050	7410	9566	395	350	291
<b>AEU 4941 xx</b>		99.0	37.0	2716	3214	3842	4545	5433	7683	9410	12148				
120°	<b>AEW 3940 xx</b>	80	36.0	15.0	271	321	384	454	543	768	940	1214	200	160	140
	<b>AEW 4118 xx</b>		40.5	14.5	341	403	482	570	681	963	1180	1523			
	<b>AEW 4147 xx</b>	100	43.0	18.5	424	502	600	710	849	1200	1470	1898	220	180	156
	<b>AEW 4188 xx</b>	125	53.0	22.0	543	642	768	908	1085	1535	1880	2427	250	210	177
	<b>AEW 4235 xx</b>		55.0	24.0	678	803	959	1135	1357	1919	2350	3034			
	<b>AEW 4294 xx</b>	150	59.0	28.0	849	1004	1200	1420	1697	2400	2940	3796	285	240	188
	<b>AEW 4370 xx</b>		66.0	32.0	1068	1264	1511	1787	2136	3021	3700	4777			
	<b>AEW 4470 xx</b>	200	75.0	35.0	1357	1605	1919	2270	2714	3838	4700	6068	340	295	250
	<b>AEW 4588 xx</b>		81.0	40.0	1697	2008	2400	2840	3395	4801	5880	7591			
	<b>AEW 4741 xx</b>	250	86.0	37.0	2139	2531	3025	3579	4278	6050	7410	9566	395	350	291
<b>AEW 4941 xx</b>		96.0	42.0	2716	3214	3842	4545	5433	7683	9410	12148				

**Typical applications**

**Cooling**

- Coke quench tower scrubber system
- Exhaust gas cooling
- High-temperature cooling

**Cleaning**

- Desulfuration
- Exhaust scrubbers

**HOW TO MAKE UP THE NOZZLE CODE**

EX.: AEU 3940 A1

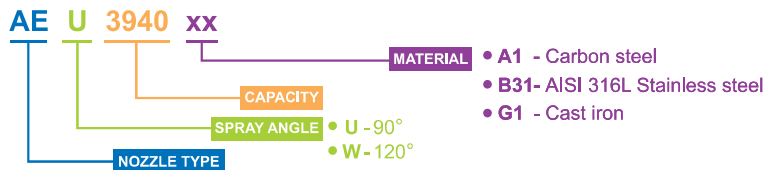

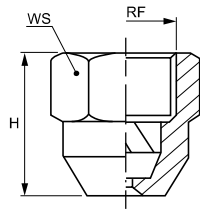

### IN-LINE FULL CONE

AH series nozzles are made of a body and a disc vane and provide a very uniform spray distribution onto the entire coverage area. AH nozzles have been widely used in continuous casting plants for many years. The special design of their vane produces a fine atomization of the liquid and highly improves its distribution. These innovative nozzles, highly appreciated for their performance, are widely used in the steelworks industry both in Europe and America.

• Thread specification: BSP, NPT

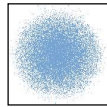

Spray section

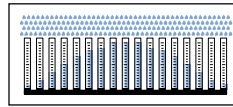

Convex distribution



#### Typical applications

##### Washing

- Steel cleaning
- Parts washing
- Pre-treatment in coating process

##### Cooling

- Continuous casting cooling
- Products cooling
- Tank cooling

##### Dust control

- Dust removal in mining and coal plants

##### Other applications

- Spray of chemicals
- Leak test



#### DISC VANE

This innovative vane is machined with high precision. Its smooth surface reduces pressure loss and avoids turbulence. Its stabilizer acts as a hydrodynamic brake on the fluid rotating at high-speed inside the whirl chamber. Its shape splits the liquid leaving the nozzle into 6 flows. Disc vanes produce micro-droplets and even atomization.

Code	RF inch	D mm	Capacity (l/min) at different pressure values (bar)					H mm	WS mm
			1.0	2.0	3.0	4.0	5.0		
65°									
AHR 1309 xx	1/4"	1.9	1.78	2.52	3.09	3.57	3.99	25.0	19
AHR 1362 xx		2.0	2.09	2.96	3.62	4.18	4.67		
AHR 1409 xx		2.2	2.36	3.34	4.09	4.72	5.28		
AHR 1517 xx		2.6	2.98	4.22	5.17	5.97	6.67		
AHR 1207 xx	3/8"	1.0	1.20	1.69	2.07	2.39	2.67	26.5	22
AHR 1258 xx		1.0	1.49	2.11	2.58	2.98	3.33		
AHR 1310 xx		1.9	1.79	2.53	3.10	3.58	4.00		
AHR 1340 xx		2.0	1.96	2.78	3.40	3.93	4.39		
AHR 1363 xx		2.1	2.10	2.96	3.63	4.19	4.69		
AHR 1415 xx		2.2	2.40	3.39	4.15	4.79	5.36		
AHR 1470 xx		2.5	2.71	3.84	4.70	5.43	6.07		
AHR 1518 xx		2.6	2.99	4.23	5.18	5.98	6.69		
AHR 1621 xx		2.7	3.59	5.07	6.21	7.17	8.02		
AHR 1780 xx		2.9	4.50	6.37	7.80	9.01	10.1		
AHR 1828 xx		3.1	4.78	6.76	8.28	9.56	10.7		
AHR 1873 xx		3.3	5.04	7.13	8.73	10.1	11.3		
AHR 2110 xx	1/2"	4.2	6.35	8.98	11.0	12.7	14.2	36.0	27
AHR 2144 xx		4.2	8.31	11.8	14.4	16.6	18.6		
AHR 2154 xx		5.0	8.89	12.6	15.4	17.8	19.9		
80°									
AHT 1309 xx	1/4"	2.2	1.78	2.52	3.09	3.57	3.99	25.0	19
AHT 1362 xx		2.2	2.09	2.96	3.62	4.18	4.67		
AHT 1409 xx		2.2	2.36	3.34	4.09	4.72	5.28		
AHT 1517 xx		2.6	2.98	4.22	5.17	5.97	6.67		
AHT 1258 xx	3/8"	2.0	1.49	2.11	2.58	2.98	3.33	26.5	22
AHT 1310 xx		2.0	1.79	2.53	3.10	3.58	4.00		
AHT 1340 xx		2.0	1.96	2.78	3.40	3.93	4.39		
AHT 1363 xx		2.1	2.10	2.96	3.63	4.19	4.69		
AHT 1415 xx		2.2	2.40	3.39	4.15	4.79	5.36		
AHT 1518 xx		2.6	2.99	4.23	5.18	5.98	6.69		
AHT 1621 xx		2.7	3.59	5.07	6.21	7.17	8.02		
AHT 1780 xx		2.9	4.50	6.37	7.80	9.01	10.1		
AHT 1828 xx		3.1	4.78	6.76	8.28	9.56	10.7		
AHT 1873 xx		3.1	5.04	7.13	8.73	10.1	11.3		
AHT 2110 xx	1/2"	4.2	6.35	8.98	11.0	12.7	14.2	36.0	27
AHT 2144 xx		4.2	8.31	11.8	14.4	16.6	18.6		
45°									
AHM 1309 xx	1/4"	2.2	1.78	2.52	3.09	3.57	3.99	25.0	19
AHM 1409 xx		2.2	2.36	3.34	4.09	4.72	5.28		
AHM 1517 xx		2.6	2.98	4.22	5.17	5.97	6.67		

### AH( FULL CONE NOZZLES / FINE MIST )

#### Spray angle 45°

#### HOW TO MAKE UP THE NOZZLE CODE

EX.: AHR 1390 B1

AH R 1309 xx

MATERIAL • B1 - AISI 303 Stainless steel

• T1 - Brass

◦ B31- AISI 316L Stainless steel (optional)

CAPACITY

SPRAY ANGLE • R-65°

• T-80°

NOZZLE TYPE



**S-TYPE VANE**

AL nozzles offer distinctive advantages due to their special construction, with an integrated S-shaped vane cast in one piece with the nozzle body with an investment casting process. The special design S-shaped vane offers the largest free passage available in a full cone nozzle (actually identical to the nozzle orifice diameter) and can easily handle dirty or recirculated liquids as well as suspended particles to avoid clogging. The best reliability is then assured under the most difficult conditions, which makes these nozzles the right choice in those plants with nozzle clogging problems or where removing and cleaning a clogged nozzle is a difficult job.

- Thread specification: BSPT, NPT

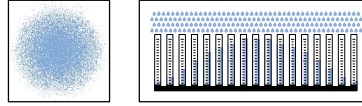

Capacity for nozzles made in PVDF, PP

ALS 70°	ALU 90°	Code	RF poll	D mm	Capacity at different pressure values (l/min) (bar)							
					0.2	0.3	0.5	0.7	1.0	2.0	3.0	5.0
•	•	2190 xx	3/8"	3.97	5.32	6.46	8.17	9.50	11.4	15.8	19.0	24.1
•	•	2250 xx		4.76	7.00	8.50	10.8	12.5	15.0	20.8	25.0	31.8
	•	2350 xx	1/2"	5.56	9.80	11.9	15.1	17.5	21.0	29.1	35.0	44.5

Capacity for nozzles made in AISI 316L

ALQ 60°	ALU 90°	ALW 120°	Code	RF poll	D mm	Capacity at different pressure values (l/min) (bar)							
						0.2	0.3	0.5	0.7	1.0	2.0	3.0	5.0
•	•	•	1927 xx	3/8"	3.18	2.60	3.14	3.99	4.68	5.53	7.66	9.27	11.8
•	•	•	2147 xx		3.97	4.13	4.99	6.35	7.43	8.79	12.2	14.7	18.7
•	•	•	2213 xx		4.76	5.96	7.21	9.17	10.7	12.7	17.6	21.3	27.1
•	•	•	2214 xx	1/2"	4.76	5.96	7.21	9.17	10.7	12.7	17.6	21.3	27.1
•	•	•	2339 xx		5.56	9.48	11.5	14.6	17.1	20.2	28.0	33.9	43.0
•	•	•	2380 xx		6.35	10.7	12.9	16.4	19.2	22.7	31.4	38.0	48.4
•	•	•	2468 xx	3/4"	7.14	13.1	15.8	20.1	23.6	27.9	38.6	46.8	59.4
•	•	•	2566 xx		7.94	15.9	19.2	24.4	28.6	33.8	46.8	56.6	72.0
•	•	•	2694 xx		8.73	19.4	23.5	29.9	35.0	41.4	57.3	69.4	88.2
•	•	•	2818 xx		9.53	22.9	27.7	35.2	41.3	48.8	67.6	81.8	104
•	•	•	2819 xx	1"	9.53	22.9	27.7	35.2	41.3	48.8	67.6	81.8	104
•	•	•	2980 xx		10.3	27.5	33.2	42.2	49.2	58.5	81.0	98.0	125
•	•	•	3115 xx		11.1	32.1	38.8	49.4	57.8	68.4	94.7	115	146
•	•	•	3116 xx	1 1/4"	11.1	32.1	38.8	49.4	57.8	68.4	94.7	115	146
•	•	•	3148 xx		12.7	41.3	49.9	63.5	74.3	87.9	122	148	187
•	•	•	3164 xx		13.5	45.8	55.4	70.5	82.5	97.6	135	164	208
•	•	•	3179 xx		14.3	50.2	60.8	77.3	90.5	107	148	179	228
•	•	•	3180 xx	1 1/2"	13.97	50.2	60.8	77.3	90.5	107	148	179	228
•	•	•	3205 xx		15.1	57.3	69.3	88.1	103	122	169	205	260
•	•	•	3218 xx		15.9	61.0	73.8	93.9	110	130	180	218	277
•	•	•	3265 xx		16.7	74.2	89.7	114	134	158	219	265	337
•	•	•	3278 xx		17.5	77.9	94.3	120	140	166	230	278	354
•	•	•	3339 xx	2"	19.1	94.8	115	146	171	202	280	339	430
•	•	•	3370 xx		20.6	104	126	160	187	221	306	370	471
•	•	•	3458 xx		22.2	129	155	197	231	273	378	458	582
•	•	•	3513 xx		23.8	144	174	221	259	306	424	513	652
•	•	•	3600 xx		25.4	168	203	259	303	358	496	600	763
•	•	•	3736 xx		28.6	206	249	317	371	439	608	736	935
•	•	•	3601 xx	2 1/2"	25.4	168	203	259	303	358	496	600	763
•	•	•	3737 xx		28.6	206	249	317	371	439	608	736	935
•	•	•	3883 xx		31.5	247	299	381	446	527	730	883	1120
•	•	•	4106 xx		34.9	297	359	456	535	632	875	1060	1350
•	•	•	4123 xx		38.1	363	440	559	655	774	1070	1230	1650
•	•	•	4124 xx	3"	37.1	363	440	559	655	774	1070	1230	1650
•	•	•	4153 xx		41.3	428	517	658	770	911	1260	1530	1940
•	•	•	4174 xx		44.5	488	591	751	880	1040	1440	1740	2220
•	•	•	4175 xx	4"	44.5	488	591	751	880	1040	1440	1740	2220
•	•	•	4196 xx		47.6	549	664	845	989	1170	1620	1960	2490
•	•	•	4230 xx		49.8	643	778	989	1160	1370	1900	2300	2920
•	•	•	4256 xx		54.0	718	869	1100	1290	1530	2120	2560	3260
•	•	•	4278 xx		57.2	779	943	1200	1400	1660	2300	2780	3540

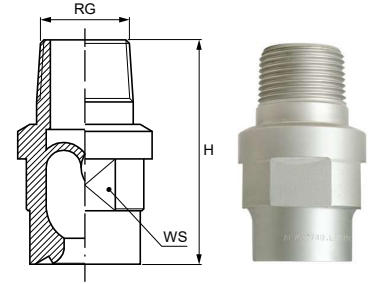

FULL CONE NOZZLES



**S vane v.s. X vane**

S-type vanes provide a large free passage of liquids through the nozzle, with nearly the same diameter of a spray tip. Therefore they offer the widest possible passage and the highest resistance to clogging among all full-cone spray nozzles with internal vane.

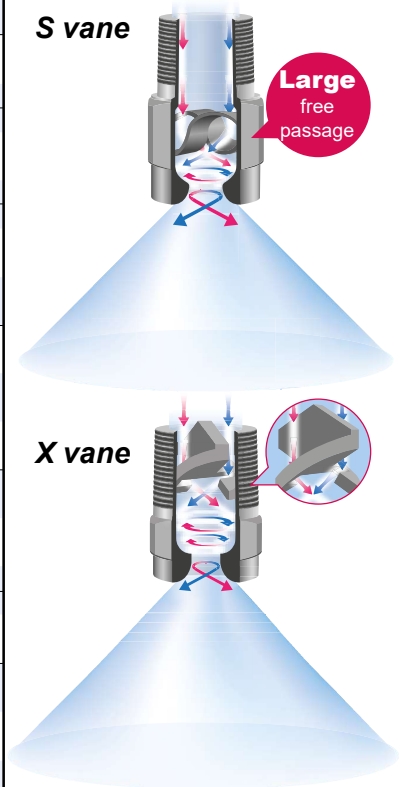

**HOW TO MAKE UP THE NOZZLE CODE**

Es.: ALU 1927 B31

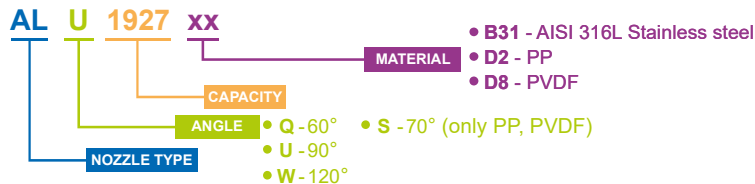

### VANELESS – OFF LINE

AT series nozzles are full cone nozzles producing a high and strong rotation of the liquid. There's no vane inside the whirl chamber which has free internal passages and for this reason these nozzles are less prone to clogging. Moreover, a specially designed tip placed at the bottom of these nozzles increases their atomizing effect. The design of AT nozzles allows a uniform spray distribution and increases their operating life by 20%.

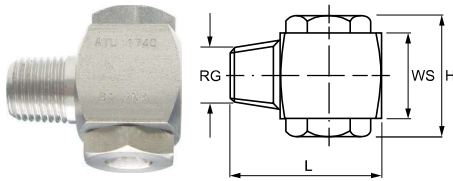

- Thread specification  
BSPT  
NPT (optional)

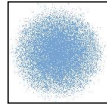

Spray section

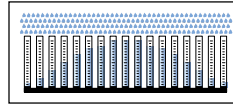

Convex distribution



#### Typical applications

##### Washing

- Exhaust scrubber
- Parts cleaning
- Pre-treatment for coating process.

##### Cooling

- Gas cooling
- Tank cooling

##### Dust control

- Remove dust flying in mining and coal plants.

##### Other applications

- Spray of chemicals
- Fire engineering

Spray Angle	Code	RG inch	D mm	D1 mm	Capacity at different pressure values (l/min)							H mm	L mm	WS mm
					1.0	2.0	3.0	4.0	5.0	6.0	7.0			
60°	ATQ 1230 xx	1/8"	2.0	1.8	1.33	1.88	2.30	2.66	2.97	3.25	3.51	22	24	15
	ATQ 1390 xx	1/4"	2.4	2.2	2.25	3.18	3.90	4.50	5.03	5.52	5.96	25	34	20
	ATQ 1490 xx		2.9	2.8	2.83	4.00	4.90	5.66	6.33	6.93	7.48			
	ATQ 1740 xx		3.3	3.2	4.27	6.04	7.40	8.54	9.55	10.5	11.3			
	ATQ 2110 xx	3/8"	5.1	4.6	6.35	8.98	11.0	12.7	14.2	15.6	16.8	27	34	20
90°	ATU 1230 xx	1/8"	2.1	1.8	1.33	1.88	2.30	2.66	2.97	3.25	3.51	22	24	15
	ATU 1390 xx	1/4"	2.5	2.1	2.25	3.18	3.90	4.50	5.03	5.52	5.96	25	34	20
	ATU 1490 xx		3.0	2.1	2.83	4.00	4.90	5.66	6.33	6.93	7.48			
	ATU 1620 xx		3.2	3.0	3.58	5.06	6.20	7.16	8.00	8.77	9.47			
	ATU 1621 xx	3/8"	3.5	3.2	3.58	5.06	6.20	7.16	8.00	8.77	9.47	27	34	20
	ATU 1780 xx		5.0	3.4	4.50	6.37	7.80	9.01	10.1	11.0	11.9			
	ATU 2110 xx		5.1	4.3	6.35	8.98	11.0	12.7	14.2	15.6	16.8			
	ATU 2153 xx		5.3	5.2	8.83	12.5	15.3	17.7	19.8	21.6	23.4			
	ATU 2245 xx	1/2"	8.7	5.5	14.1	20.0	24.5	28.3	31.6	34.6	37.4	38	48	30
	ATU 2315 xx		8.7	6.5	18.2	25.7	31.5	36.4	40.7	44.5	48.1			
	ATU 2385 xx		8.8	7.2	22.2	31.4	38.5	44.5	49.7	54.4	58.8			
	ATU 2530 xx	3/4"	12.6	8.7	30.6	43.3	53.0	61.2	68.4	75.0	81.0	50	58	40
ATU 2770 xx		12.6	11.2	44.5	62.9	77.0	88.9	99.4	109	118				
ATU 2420 xx	1"	9.2	9.8	24.2	34.3	42.0	48.5	54.2	59.4	64.2	48	61	42	
ATU 2645 xx		10.3	10.3	37.2	52.7	64.5	74.5	83.3	91.2	98.5				
ATU 2870 xx		16.0	11.5	50.2	71.0	87.0	100	112	123	133				
120°	ATW 1310 xx	1/8"	2.5	2.1	1.79	2.53	3.10	3.58	4.00	4.38	4.74	22	24	15
	ATW 1311 xx	1/4"	2.5	2.1	1.79	2.53	3.10	3.58	4.00	4.38	4.74	25	34	20
	ATW 1490 xx		4.1	2.4	2.83	4.00	4.90	5.66	6.33	6.93	7.48			
	ATW 1491 xx	3/8"	4.2	2.7	2.83	4.00	4.90	5.66	6.33	6.93	7.48	27	34	20
	ATW 1621 xx		4.5	3.2	3.58	5.06	6.20	7.16	8.00	8.77	9.47			
	ATW 1780 xx		5.0	3.4	4.50	6.37	7.80	9.01	10.1	11.0	11.9			
	ATW 2110 xx		5.4	4.4	6.35	8.98	11.0	12.7	14.2	15.6	16.8			
	ATW 2245 xx	1/2"	8.5	5.5	14.1	20.0	24.5	28.3	31.6	34.6	37.4	38	48	30
	ATW 2315 xx		8.5	6.3	18.2	25.7	31.5	36.4	40.7	44.5	48.1			
	ATW 2231 xx	3/4"	8.4	5.2	13.3	18.8	23.0	26.6	29.7	32.5	35.1	56	59	40
	ATW 2385 xx		8.8	7.3	22.2	31.4	38.5	44.5	49.7	54.5	58.8			
	ATW 2480 xx		12.6	7.8	27.7	39.2	48.0	55.4	62.0	67.9	73.3			
	ATW 2770 xx		14.0	10.7	44.5	62.9	77.0	88.9	99.4	109	118			
ATW 2420 xx	1"	9.5	8.0	24.2	34.3	42.0	48.5	54.2	59.4	64.2	48	61	42	
ATW 2645 xx		12.8	9.2	37.2	52.7	64.5	74.5	83.3	91.2	98.5	58	61	40	
ATW 2870 xx		16.0	11.5	50.2	71.0	87.0	100	112	123	133	61	68	45	
ATW 3122 xx		18.0	14.0	70.4	99.6	122	141	158	173	186	66	76	50	

#### HOW TO MAKE UP THE NOZZLE CODE

EX.: ATQ 1230 B1

AT Q 1230 xx

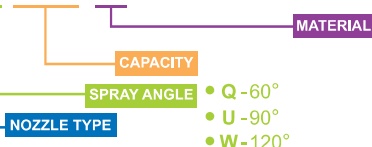

- MATERIAL
  - B1 - AISI 303 Stainless steel
  - B31 - AISI 316L Stainless steel
  - T1 - Brass

- SPRAY ANGLE
  - Q - 60°
  - U - 90°
  - W - 120°

X-VANE / ROUND SPRAY / THREE PIECES DESIGN / EASY CLEAN

BA/BC series full cone nozzles have a three-piece design made of body, X-vane and nipple. Their X-vane design combines resistance to clogging with the convenience of an easy and fast inside cleaning as they can be easily disassembled for maintenance. When these nozzles are mounted to spray upwards, the design of the nipple avoids losing the vane. BA/BC nozzles are available with a female (BA) or male (BC) inlet thread nipple. See dimensions and weight at the bottom of the page.



- Thread specification  
Male ( BSPT, NPT )  
Female ( BSP, NPT )

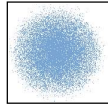

Spray section

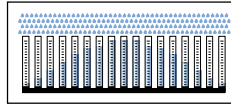

Convex distribution

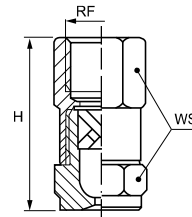

BA

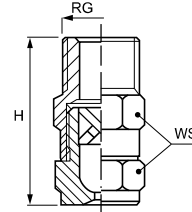

BC

FULL CONE NOZZLES

BAQ Female	BCQ Male	Code	RF RG inch	D mm	D1 mm	Capacity at different pressure values (l/min) (bar)								Spray angle at pressure (°) (bar)		
						0.7	1.0	2.0	3.0	5.0	7.0	10	0.5	1.5	6.0	
•	•	0740	1/8"	1.0	0.5	0.36	0.43	0.60	0.74	0.96	1.13	1.35	--	58°	53°	
•	•	1110		1.2	0.5	0.53	0.64	0.90	1.10	1.42	1.68	2.01	52°	65°	59°	
•	•	1150		1.4	1.0	0.73	0.87	1.23	1.50	1.94	2.29	2.74	43°	50°	46°	
•	•	1220		1.6	1.0	1.06	1.27	1.80	2.20	2.84	3.36	4.02	52°	65°	59°	
•	•	1260		1.6	1.3	1.26	1.50	2.12	2.60	3.36	3.97	4.75	43°	50°	46°	
•	•	1370		2.0	1.3	1.79	2.14	3.02	3.70	4.78	5.65	6.76	52°	65°	59°	
•	•	1480	1/4"	2.4	1.7	2.32	2.77	3.92	4.80	6.20	7.33	8.76	45°	50°	46°	
•	•	1740		2.9	1.7	3.58	4.27	6.04	7.40	9.55	11.3	13.5	58°	67°	61°	
•	•	1930		3.2	1.7	4.49	5.37	7.59	9.30	12.0	14.2	17.0	69°	74°	68°	
•	•	1700	3/8"	3.0	2.0	3.38	4.04	5.72	7.00	9.04	10.7	12.8	45°	50°	46°	
•	•	2111		3.4	2.4	5.36	6.41	9.06	11.1	14.3	17.0	20.3	64°	67°	61°	
•	•	2163		4.5	2.4	7.87	9.41	13.3	16.3	21.0	24.9	29.8	87°	90°	82°	
•	•	2118	1/2"	3.4	3.0	5.70	6.81	9.63	11.8	15.2	18.0	21.5	48°	50°	46°	
•	•	2185		4.4	3.0	8.94	10.7	15.1	18.5	23.9	28.3	33.8	64°	67°	61°	
•	•	2240		5.0	3.0	11.6	13.9	19.6	24.0	31.0	36.7	43.8	72°	75°	68°	
•	•	2300		5.6	3.0	14.5	17.3	24.5	30.0	38.7	45.8	54.8	88°	91°	83°	

Standard spray

BAW	BCW	Code	RF/RG	D	D1	Capacity at different pressure values (l/min)								Spray angle at pressure (°)		
						0.7	1.0	2.0	3.0	5.0	7.0	10	0.3	0.7	6.0	
•	•	1200	1/8"	1.5	1.0	0.97	1.15	1.63	2.00	2.58	3.06	3.65	--	120°	102°	
•	•	1310		1.8	1.0	1.50	1.79	2.53	3.10	4.00	4.74	5.66	--	120°	102°	
•	•	1400		2.3	1.0	1.93	2.31	3.27	4.00	5.16	6.11	7.30	--	120°	102°	
•	•	1570		2.5	1.1	2.75	3.29	4.65	5.70	7.36	8.71	10.4	--	120°	103°	
•	•	1720	1/4"	3.3	1.7	3.48	4.16	5.88	7.20	9.30	11.0	13.2	112°	120°	103°	
•	•	1860		3.4	1.3	4.15	4.97	7.02	8.60	11.1	13.1	15.7	114°	120°	103°	
•	•	2100		3.6	1.6	4.83	5.77	8.16	10.0	12.9	15.3	18.3	114°	120°	103°	
•	•	2122	3/8"	3.9	1.6	5.89	7.04	9.96	12.2	15.8	18.6	22.3	114°	120°	103°	
•	•	2144		4.3	2.4	6.96	8.31	11.8	14.4	18.6	22.0	26.3	114°	120°	104°	
•	•	2172		4.9	2.4	8.31	9.93	14.0	17.2	22.2	26.3	31.4	114°	120°	104°	
•	•	2194		5.3	2.5	9.37	11.2	15.8	19.4	25.1	29.6	35.4	114°	120°	106°	
•	•	2220	1/2"	5.0	3.0	10.6	12.7	18.0	22.0	28.4	33.6	40.2	114°	120°	108°	
•	•	2250		5.3	3.0	12.1	14.4	20.4	25.0	32.3	38.2	45.6	114°	120°	108°	
•	•	2290		5.6	3.0	14.0	16.7	23.7	29.0	37.4	44.3	53.0	114°	120°	108°	
•	•	2320		6.7	3.5	15.5	18.5	26.1	32.0	41.3	48.9	58.4	114°	120°	110°	
•	•	2360		7.6	4.0	17.4	20.8	29.4	36.0	46.5	55.0	65.7	114°	120°	112°	

Wide spray

Typical applications

- Washing**  
Exhaust scrubbers  
Parts cleaning  
Pre-treatment for coating process
- Cooling**  
Exhaust cooling  
Tank cooling
- Dust control**  
Remove dust flying in a mining and coal plants.
- Other applications**  
Spray of chemicals  
Fire engineering

Nozzle type	RF inch	H mm	WS mm	W kg
BA Female	1/8"	30	14	0.03
	1/4"	37	17	0.04
	3/8"	46	19	0.07
	1/2"	57	25	0.20

Nozzle type	RG inch	H mm	WS mm	W kg
BC Male	1/8"	32	14	0.02
	1/4"	39	17	0.04
	3/8"	47	19	0.07
	1/2"	57	25	0.20

Dimensions & weights

HOW TO MAKE UP THE NOZZLE CODE

EX.: BAQ 0740 B1

BA Q 0740 XX

- NOZZLE TYPE**: BA
- SPRAY ANGLE**: Q - 60°  
W - 120°
- CAPACITY**: 0740
- MATERIAL**:
  - B1 - AISI 303 Stainless steel
  - B31 - AISI 316L Stainless steel
  - T1 - Brass
  - E1 - PTFE
  - L61 - Hastelloy C22



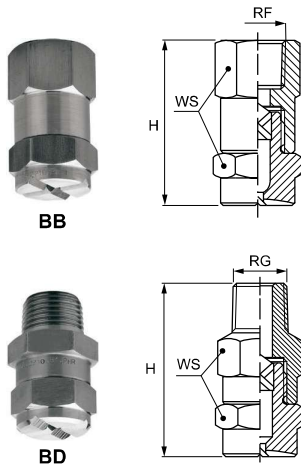

### X VANE / SQUARE SPRAY PATTERN / THREE-PIECE DESIGN / EASY CLEAN

BB/BD series full cone nozzles offer a three-piece design made of body, X-vane and connection. BB/BD series nozzles supply a square section spray pattern and are suitable for working environments that strictly require a uniform coverage. The most important feature of BB/BD series nozzle is their X-vane which can be easily disassembled. It is mounted between its body and connection, allowing the narrowest passage to avoid clogging. The best choice to solve clogging problems.

- **Thread specification**  
Male ( BSPT, NPT )  
Female ( BSP, NPT )

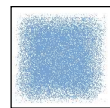

Spray section

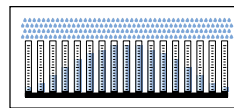

Convex distribution



### SQUARE SPRAY

BBQ Female	BDQ Male	Code	RF RG inch	D mm	D1 mm	Capacity at different pressure values (l/min) (bar)						Spray angle at pressure (°) (bar)			
						0,7	1,0	2,0	3,0	5,0	7,0	10	0,5	1,5	6,0
•	•	1270	1/8"	1,8	1,0	1,30	1,56	2,21	2,70	3,49	4,12	4,93	40°	52°	47°
•	•	1360		1,9	1,3	1,74	2,08	2,94	3,60	4,65	5,50	6,57	48°	63°	57°
•	•	1440		2,1	1,3	2,13	2,54	3,59	4,40	5,68	6,72	8,03	60°	66°	60°
•	•	1740	1/4"	2,8	1,6	3,58	4,27	6,04	7,40	9,55	11,3	13,5	62°	67°	61°
•	•	1890		3,2	1,6	4,30	5,14	7,27	8,90	11,5	13,6	16,3	70°	75°	68°
•	•	2110		3,8	1,6	5,31	6,35	8,98	11,0	14,2	16,8	20,1	78°	82°	75°
•	•	2133	3/8"	3,8	2,4	6,42	7,68	10,9	13,3	17,2	20,3	24,3	71°	75°	68°
•	•	2210	1/2"	5,6	3,0	10,1	12,1	17,2	21,0	27,1	32,1	38,3	71°	75°	68°
•	•	2270		6,4	3,2	13,0	15,6	22,1	27,0	34,9	41,2	49,3	78°	82°	75°

BB/BD series nozzles produce a square spray pattern. The flat spray orientation is set with a 10°-15° offset angle from the main manifold axis to avoid jet overlapping. Therefore the correct alignment of these nozzles is very important and must be done properly. Please refer to the table below.

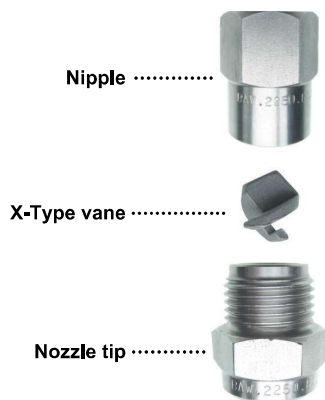

### DIMENSIONS AND WEIGHTS

Nozzle type	RF inch	H mm	WS mm	W kg
BB Female	1/8"	30	14	0.03
	1/4"	37	17	0.04
	3/8"	46	19	0.07
	1/2"	57	25	0.20

Nozzle type	RG inch	H mm	WS mm	W kg
BD Male	1/8"	32	14	0.02
	1/4"	39	17	0.04
	3/8"	47	19	0.07
	1/2"	57	25	0.20

### Typical applications

- Washing:** exhaust scrubbers, parts cleaning, pre-treatment for coating processes
- Cooling:** exhaust gas cooling, tank cooling
- Coating:** oil coating, spray of chemicals
- Other applications:** dust control, leak test

### HOW TO MAKE UP THE NOZZLE CODE

EX.: BBQ 1270 B1

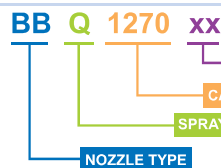

**MATERIAL**

- B1 - AISI 303 Stainless steel
- B31 - AISI 316L Stainless steel
- T1 - Brass (optional)

**CAPACITY**

**SPRAY ANGLE** • Q - 60°

**NOZZLE TYPE**

X-VANE / SQUARE SPRAY PATTERN / TWO-PIECE DESIGN

BF/BH type nozzles have a simple two-piece design producing a square section spray pattern. They are the convenient choice where the coverage of a surface is required to be as even as possible. Their X-vane ensures uniform spray distribution and resistance to clogging, also when working with large capacities. The sides of the square spray section are not aligned with the grooves of the nozzle orifice and the offset angle is between 10° and 15° depending on working pressure and distance from the impact surface. Therefore, utmost attention must be paid during the nozzles overlay setting. They must be carefully aligned and adjusted according to the operating situation.



BH



BF

- **Thread specification**  
Male ( BSPT, NPT )  
Female ( BSP, NPT )

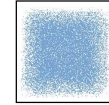

Spray section

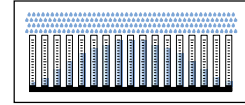

Convex distribution

FULL CONE NOZZLES

BFS Female	BHQ Male	Code	RF RG inch	D mm	D1 mm	Capacity (l/min) at different pressure values (bar)							Spray angle (°) at pressure (bar)			
						0.7	1.0	2.0	3.0	5.0	7.0	10	0.5	1.5	3.0	6.0
	•	1270	1/8"	1.7	1.3	1.30	1.56	2.21	2.70	3.49	4.12	4.93	40°	52°	60°	47°
	•	1350		1.9	1.3	1.69	2.02	2.86	3.50	4.52	5.35	6.39	48°	63°	60°	57°
	•	1440		2.2	1.3	2.13	2.54	3.59	4.40	5.68	6.72	8.03	60°	66°	65°	60°
	•	1740	1/4"	2.8	1.6	3.58	4.27	6.04	7.40	9.55	11.3	13.5	62°	67°	65°	61°
	•	1890		3.2	1.6	4.30	5.14	7.27	8.90	11.5	13.6	16.3	70°	75°	65°	68°
	•	2107		3.8	1.6	5.17	6.18	8.74	10.7	13.8	16.3	19.5	78°	82°	65°	75°
	•	2133	3/8"	4.0	2.4	6.42	7.68	10.9	13.3	17.2	20.3	24.3	71°	75°	62°	68°
	•	2210	1/2"	5.5	3.2	10.1	12.1	17.1	21.0	27.1	32.1	38.3	71°	75°	64°	68°
	•	2270		6.4	3.2	13.0	15.6	22.1	27.0	34.9	41.2	49.3	78°	82°	65°	75°
	•	2370	3/4"	6.7	4.4	17.9	21.4	30.2	37.0	47.8	56.5	67.6	71°	75°	64°	68°
•		2780	1"	1.9	1.3	37.7	45.0	63.7	78.0	101	119	142	78°	80°	78°	73°
•		3131	1 1/4"	2.4	1.3	63.3	75.6	107	131	169	200	239	78°	80°	78°	73°
•		3170	1 1/2"	2.8	1.6	82.1	98.1	139	170	219	260	310	73°	77°	78°	70°
•		3215	2"	3.2	1.6	104	124	176	215	278	328	393	66°	70°	72°	64°
•		3265		3.8	1.6	128	153	216	265	342	405	484	70°	74°	75°	67°
•		3355		1.6	1.3	171	205	290	355	458	542	648	79°	82°	75°	74°
•		3360	2 1/2"	1.9	1.3	174	208	294	360	465	550	657	62°	67°	70°	61°
•		3435		2.4	1.3	210	251	355	435	562	664	794	75°	78°	80°	71°
•		3700		2.8	1.6	338	404	572	700	904	1069	1278	81°	84°	76°	76°
•		4220	5"	1.9	1.3	1063	1270	1796	2200	2840	3361	4017	89°	91°	75°	83°
•		4420	6"	2.4	1.3	2029	2425	3429	4200	5422	6416	7668	102°	105°	78°	95°

Standard spray angle

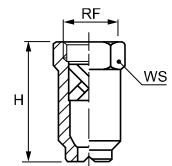
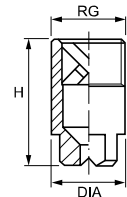
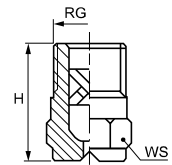

Wide spray angle

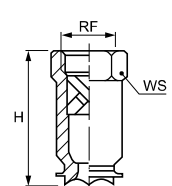
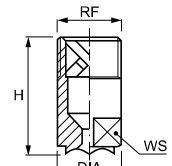
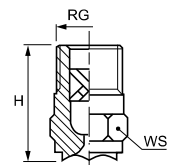

BFW Female	BHW Male	Code	RF RG mm	D mm	D1 mm	Capacity (l/min) at different pressure values (bar)							Spray angle(°) at pressure(bar)		
						0.7	1.0	2.0	3.0	5.0	7.0	10	0.3	0.7	6.0
	•	2100	1/4"	3.2	1.6	4.83	5.77	8.16	10.0	12.9	15.3	18.3	99°	101°	93°
	•	2122	3/8"	3.9	1.6	5.89	7.04	9.96	12.2	15.8	18.6	22.3	99°	101°	93°
	•	2144		4.0	2.4	6.96	8.31	11.8	14.4	18.6	22.0	26.3	104°	110°	94°
	•	2172		4.6	2.4	8.31	9.93	14.0	17.2	22.2	26.3	31.4	104°	110°	94°
	•	2194		5.4	2.4	9.37	11.2	15.8	19.4	25.0	29.6	35.4	104°	110°	98°
	•	2220	1/2"	4.8	3.0	10.6	12.7	18.0	22.0	28.4	33.6	40.2	104°	110°	102°
	•	2250		5.1	3.0	12.1	14.4	20.4	25.0	32.3	38.2	45.6	104°	110°	102°
	•	2290		5.7	3.0	14.0	16.7	23.7	29.0	37.4	44.3	52.9	104°	110°	102°
	•	2320		7.0	3.0	15.5	18.5	26.1	32.0	41.3	48.9	58.4	104°	110°	102°
	•	2360		8.0	3.0	17.4	20.8	29.4	36.0	46.5	55.0	65.7	104°	110°	102°
•	•	2500	3/4"	8.5	4.5	24.2	28.9	40.8	50.0	64.6	76.4	91.3	105°	110°	102°
•	•	2930	1"	11.6	5.6	44.9	53.7	75.9	93.0	120	142	170	107°	110°	107°
•		3134	1 1/4"	14.5	6.0	64.7	77.4	109	134	173	205	245	108°	111°	109°
•		3200	1 1/2"	18.2	9.0	96.6	115	163	200	258	306	365	109°	114°	109°
•		3395	2"	24.0	11.1	191	228	323	395	510	603	721	110°	114°	109°
•		3590	2 1/2"	26.0	14.3	285	341	482	590	762	901	1077	110°	115°	109°
•		3800	3"	31.5	17.5	386	462	653	800	1033	1222	1461	110°	115°	109°

Dimensions and weights

Size	inch	1/8"	1/4"	3/8"	1/2"	3/4"	1"	1 1/4"	1 1/2"	2"	2 1/2"	3"	5"	6"	
H	mm	22	23	30	39	55	70	88	102	138	175	187	311	366	
WS	mm	12	14	17	21	27	32	40	50	60	85	100	170	200	
DIA	mm					32	38								
W	kg	0.01	0.02	0.03	0.04	0.20	0.35	0.55	0.80	1.6	2.0	7.8	18	25	
Manufacture		Machine						Casting							

HOW TO MAKE UP THE NOZZLE CODE

EX.: BFS 2780 B1

BF S 2780 XX

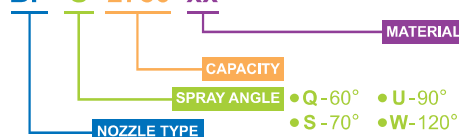

- B1 - AISI 303 Stainless steel
- B31 - AISI 316L Stainless steel
- T1 - Brass
- D1 - PVC
- E1 - PTFE



BE

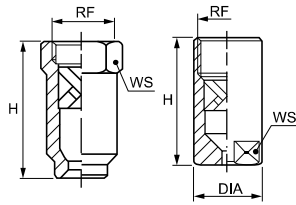

BG

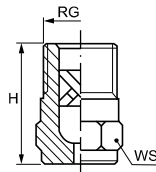

### X-VANE / ROUND SPRAY / TWO-PIECE DESIGN

BE/BG series nozzles have a two-piece design producing a full cone round spray pattern with angles ranging between 70° and 120°. Their X-vane ensures uniform spray distribution and resistance to clogging, also when working with large capacities. For this important feature these nozzles are a widely popular choice. The table on this page shows BE/BG threaded nozzles up to size 3". Nozzles with larger capacities with either threaded or flanged connections are shown on the next page.

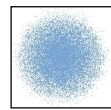

Spray section

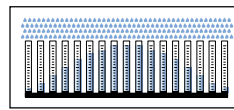

Convex distribution



### STANDARD SPRAY ANGLES

Nozzle type		Code	RF RG	D mm	D1 mm	Capacity (l/min)										Spray angle (°)		
BES Female	BGQ Male					at different pressure values (bar)										at pressure (bar)		
						0.5	1.0	2.0	3.0	5.0	7.0	10	0.5	1.5	6.0			
	•	1480 xx	1/4"	2.3	1.6	1.96	2.77	3.92	4.80	6.20	7.33	8.76	45°	50°	46°			
	•	1740 xx		2.9	1.6	3.02	4.27	6.04	7.40	9.55	11.3	13.5	58°	67°	61°			
	•	1700 xx	3/8"	2.6	2.4	2.86	4.04	5.72	7.00	9.04	10.7	12.8	45°	50°	46°			
	•	2111 xx		3.6	2.4	4.53	6.41	9.06	11.1	14.3	17.0	20.3	64°	67°	61°			
	•	2163 xx		4.5	2.8	6.65	9.41	13.3	16.3	21.0	24.9	29.8	87°	90°	82°			
	•	2185 xx	1/2"	4.6	3.2	7.55	10.7	15.1	18.5	23.9	28.3	33.8	64°	67°	61°			
	•	2300 xx		6.3	3.6	12.3	17.3	24.5	30.0	38.7	45.8	54.8	88°	91°	83°			
	•	2220 xx	3/4"	4.9	4.4	8.98	12.7	18.0	22.0	28.4	33.6	40.2	48°	50°	46°			
	•	2350 xx		6.4	4.4	14.3	20.2	28.6	35.0	45.2	53.5	63.9	67°	70°	63°			
	•	2610 xx		9.5	5.2	24.9	35.2	49.8	61.0	78.8	93.2	111	89°	92°	84°			
	•	2370 xx	1"	6.0	5.6	15.1	21.4	30.2	37.0	47.8	56.5	67.6	48°	50°	46°			
	•	2611 xx		8.3	5.6	24.9	35.2	49.8	61.0	78.8	93.2	111	67°	68°	62°			
	•	2870 xx		11.9	5.6	35.5	50.2	71.0	87.0	112	133	159	78°	90°	94°			
	•	3104 xx		11.9	6.4	42.5	60.0	84.9	104	134	159	190	89°	92°	84°			
	•	2520 xx	1 1/4"	7.4	6.4	21.2	30.0	42.5	52.0	67.1	79.4	95	48°	50°	44°			
	•	2871 xx		9.6	6.4	35.5	50.2	71.0	87.0	112	133	159	64°	67°	58°			
	•	3105 xx		10.7	6.4	42.9	60.6	85.7	105	136	160	192	66°	70°	60°			
	•	3122 xx		12.3	6.4	49.8	70.4	99.6	122	158	186	222	77°	80°	70°			
	•	3174 xx		15.1	7.9	71.0	100	142	174	225	266	318	90°	93°	81°			
	•	2872 xx	1 1/2"	9.5	8.7	35.5	50.2	71.0	87.0	112	133	159	48°	50°	44°			
	•	3139 xx		12.7	8.7	56.8	80.3	113	139	180	212	254	72°	74°	64°			
	•	3175 xx		14.3	8.7	71.4	101	143	175	226	267	320	74°	76°	66°			
	•	3260 xx		18.3	10.3	106	150	212	260	336	397	475	91°	94°	82°			
	•	3148 xx	2"	12.7	11.1	60.4	85.5	121	148	191	226	270	49°	50°	44°			
	•	3261 xx		17.3	11.1	106	150	212	260	336	397	475	72°	74°	64°			
	•	3305 xx		19.2	11.1	125	176	249	305	394	466	557	75°	77°	68°			
	•	3350 xx		21.0	11.1	143	202	286	350	452	535	639	78°	80°	70°			
	•	3435 xx		23.8	14.3	178	251	355	435	562	665	794	83°	85°	75°			
	•	3520 xx		28.6	14.3	212	300	425	520	671	794	949	98°	100°	86°			
	•	3215 xx	2 1/2"	15.1	14.3	87.8	124	176	215	278	328	393	49°	50°	44°			
	•	3436 xx		22.2	14.3	178	251	355	435	562	665	794	72°	74°	64°			
	•	3521 xx		24.6	14.3	212	300	425	520	671	794	949	76°	78°	68°			
	•	3610 xx		28.6	14.3	249	352	498	610	788	932	1114	79°	82°	72°			
	•	3700 xx		28.6	17.5	286	404	572	700	904	1069	1278	86°	88°	77°			
	•	3780 xx		31.8	17.5	318	450	637	780	1007	1192	1424	95°	97°	84°			
	•	3365 xx	3"	19.1	17.5	149	211	298	365	471	558	666	49°	50°	44°			
	•	3701 xx		27.8	17.5	286	404	572	700	904	1069	1278	81°	84°	73°			
	•	3781 xx		30.2	17.5	318	450	637	780	1007	1192	1424	86°	89°	77°			
	•	3870 xx		32.5	17.5	355	502	710	870	1123	1329	1588	92°	95°	83°			
	•	4104 xx		34.9	20.6	425	600	849	1040	1343	1589	1899	102°	105°	89°			

#### Thread specification

Male ( BSPT, NPT )  
Female ( BSP, NPT )

#### Typical applications

- Washing**
  - Food cleaning
  - Parts cleaning
  - Pre-treatment for coating process
- Cooling**
  - Steel cooling
  - Product cooling
  - Tank cooling
- Other applications**
  - Desulfuration
  - Leak test

#### Material

- B1 AISI 303
- B31 AISI 316L
- T1 Brass, only sizes 1" and smaller
- E1 PTFE
- L61 Hastelloy C22

### DIMENSIONS

BG Male	Size	inch	1/4"	3/8"	1/2"	3/4"	1"	1 1/4"	1 1/2"	2"	2 1/2"	3"
	H	mm	22.0	25.0	33.0	40.0	51.5					
WS	mm	14.0	17.0	22.0	22.0	27.0						
BE Female	H	mm				55.5	68.0	90.0	105	140	180	192
	DIA	mm				32.0	38.0					
	WS	mm				27.0	32.0	48.0	52.0	67.0	85.0	100

**WIDE SPRAY ANGLES**

Nozzle type		Code	RF RG	D	D1	Capacity at different pressure values							Spray angle at pressure		
BEW	BGW					(l/min)							(°)		
Female	Male					(bar)							(bar)		
			inch	mm	mm	0.5	1.0	2.0	3.0	5.0	7.0	10	0.3	0.7	6.0
•	•	2100 xx	1/4"	3.3	1.6	4.08	5.77	8.16	10.0	12.9	15.3	18.3	114°	120°	103°
•	•	2122 xx	3/8"	3.6	2.4	4.98	7.04	9.96	12.2	15.8	18.6	22.3	114°	120°	103°
•	•	2144 xx		4.0	2.4	5.88	8.31	11.8	14.4	18.6	22.0	26.3	114°	120°	104°
•	•	2172 xx		5.1	2.4	7.02	9.93	14.0	17.2	22.2	26.3	31.4	114°	120°	104°
•	•	2194 xx		5.2	2.8	7.92	11.2	15.8	19.4	25.0	29.6	35.4	114°	120°	106°
•	•	2220 xx	1/2"	5.0	3.0	8.98	12.7	18.0	22.0	28.4	33.6	40.2	114°	120°	108°
•	•	2250 xx		5.4	3.0	10.2	14.4	20.4	25.0	32.3	38.2	45.6	114°	120°	108°
•	•	2290 xx		6.4	3.0	11.8	16.7	23.7	29.0	37.4	44.3	53.0	114°	120°	108°
•	•	2320 xx		6.9	3.0	13.1	18.5	26.1	32.0	41.3	48.9	58.4	114°	120°	110°
•	•	2360 xx		7.6	3.0	14.7	20.8	29.4	36.0	46.5	55.0	65.7	114°	120°	112°
•	•	2500 xx	3/4"	8.7	4.5	20.4	28.9	40.8	50.0	64.6	76.4	91.3	115°	120°	112°
•	•	2920 xx	1"	11.5	5.6	37.6	53.1	75.1	92.0	119	141	168	117°	120°	117°
•	•	3134 xx	1 1/4"	14.0	6.0	54.7	77.4	109	134	173	205	245	118°	121°	119°
•	•	3200 xx	1 1/2"	16.5	9.0	81.7	116	163	200	258	306	365	119°	124°	119°
•	•	3395 xx	2"	24.0	11.1	161	228	323	395	510	603	721	120°	124°	119°
•	•	3590 xx	2 1/2"	26.0	14.3	241	341	482	590	762	901	1077	120°	125°	119°
•	•	3800 xx	3"	32.0	17.5	327	462	653	800	1033	1222	1461	120°	125°	119°

FULL CONE NOZZLES

( FULL CONE NOZZLES ) **BE / BL**

**X-VANE / LARGE CAPACITIES**

BE/BL series large capacity nozzles feature a full cone spray pattern with uniform distribution over a round impact area, ranging between 90° and 120° and for applications where a very large capacity is required. The bodies are machined from a casting, and can be finished either with a female thread connection (BE type) or with an integral ANSI flange (BL type).

Thread specification : BSP, NPT

Flange specification : DIN Standard, JIS Standard (optional)

Typical applications : desulfuration, coke quenching

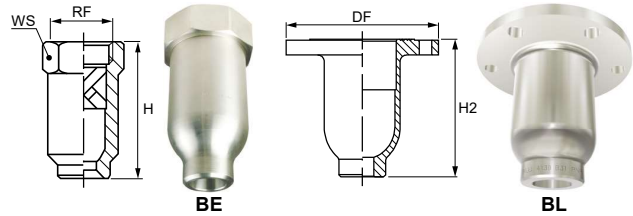

**LARGE CAPACITY**

Nozzle type	Code	RF RG	D	D1	Capacity at different pressure values							Spray angle at pressure			Dimension mm				
					BEU	BLU	(l/min)							(°)			mm		
					Casting	Flange	(bar)							(bar)			H	H2	WS
			inch	mm	mm	0.7	1.0	2.0	3.0	5.0	7.0	10	0.5	1.5	6.0				
90°	•	•	4139 xx	4"	43	19	671	803	1135	1390	1794	2123	2538	87°	90°	70°	251	207	130
	•	•	4157 xx		47	22	758	906	1282	1570	2027	2398	2866	92°	95°	83°			
	•	•	4174 xx		51	25	840	1005	1421	1740	2246	2658	3177	97°	100°	87°			
	•	•	4183 xx		54	25	884	1057	1494	1830	2363	2795	3341	102°	105°	91°			
	•	•	4218 xx	5"	48	29	1053	1259	1780	2180	2814	3330	3980	89°	91°	80°	311	269	170
	•	•	4244 xx		53	29	1179	1409	1992	2440	3150	3727	4455	93°	96°	84°			
	•	•	4279 xx		68	35	1348	1611	2278	2790	3602	4262	5094	97°	100°	87°			
	•	•	4287 xx		73	35	1386	1657	2343	2870	3705	4384	5240	102°	105°	91°			
	•	•	4305 xx	6"	61	41	1473	1761	2490	3050	3938	4659	5569	87°	90°	78°	366	321	200
	•	•	4348 xx		70	41	1681	2009	2841	3480	4493	5316	6354	92°	95°	83°			
	•	•	4392 xx		77	44	1894	2263	3201	3920	5061	5988	7157	97°	100°	87°			
	•	•	4418 xx		82	44	2019	2413	3413	4180	5396	6385	7632	102°	105°	91°			
	•	•	4435 xx	8"	70	48	2101	2511	3552	4350	5616	6645	7942	78°	80°	70°	470	423	240
	•	•	4520 xx		80	47	2512	3002	4246	5200	6713	7943	9494	86°	88°	77°			
	•	•	4610 xx		91	47	2947	3522	4981	6100	7875	9318	11137	92°	95°	83°			
	•	•	4694 xx		102	57	3352	4007	5666	6940	8960	10601	12671	102°	105°	91°			
•	•	4785 xx		124	57	3792	4532	6409	7850	10134	11991	14332	106°	110°	96°				
•	•	4695 xx	10"	102	57	3357	4013	5675	6950	8972	10616	12689	78°	80°	70°		527		
•	•	4870 xx		102	64	4202	5023	7104	8700	11232	13289	15884	86°	89°	77°				
•	•	5104 xx		122	67	5024	6004	8492	10400	13426	15886	18988	97°	100°	87°				
•	•	5113 xx		135	67	5458	6524	9226	11300	14588	17261	20631	103°	106°	92°				

Nozzle type	Code	RF RG	D	D1	Capacity (l/min) at different pressure values (bar)							Dimension mm		
					0.7	1.0	2.0	3.0	5.0	7.0	10	H	WS	
120°	•	4158 xx	4"	47	22	758	906	1282	1570	2027	2398	2538	251	130

**HOW TO MAKE UP THE NOZZLE CODE**

EX.: BEU 4139 B31

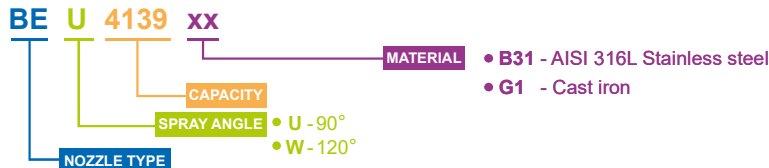





### X-VANE / NARROW SPRAY ANGLE

BR/BU nozzles produce a solid cone spray with round spray pattern, where coarse water drops are concentrated within a narrow spray angle to maximize their impact force per square surface unit. Spray angle values of 15° or 30° are available, with a choice of male or female thread connections. BR/BS nozzles are made of three pieces designed to allow their easy disassembly and cleaning in case of clogging.

- **Thread specification**  
Male ( BSPT, NPT )  
Female ( BSP, NPT )

- **Typical applications**  
bottles washing, parts cleaning,  
deep cleaning

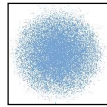

Spray section

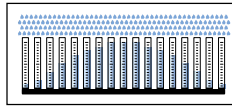

Convex distribution



### SPRAY ANGLE 15°

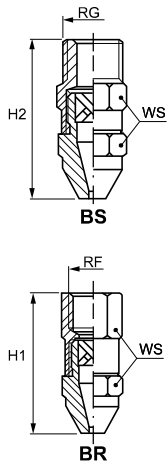

BRB Female	BSB Male	BUB Female	Code	RF RG inch	D mm	Capacity at different pressure values (l/min) (bar)					Dimension mm			
						1.0	2.0	3.0	5.0	10	DIA	H1	H2	WS
•	•		1270 xx	1/8"	1.6	1.56	2.20	2.70	3.49	4.93		33	35	12
•	•		1550 xx	1/8"	2.3	3.18	4.49	5.50	7.10	10.0				
•	•		2117 xx	1/4"	3.2	6.75	9.55	11.7	15.1	21.4		44	44	17
•	•		2196 xx	3/8"	4.2	11.3	16.0	19.6	25.3	35.8		53	53	22
•	•		2352 xx	1/2"	5.6	20.3	28.7	35.2	45.4	64.3		72	72	24
		•	2587 xx	3/4"	7.8	33.9	47.9	58.7	75.8	107	32	72		25
		•	3110 xx	1"	10.2	63.5	89.8	110	142	201	40	92		35
		•	3168 xx	1 1/4"	12.6	97.0	137	168	217	307	48	117		40
		•	3245 xx	1 1/2"	15.1	141	200	245	316	447	60	127		52
		•	3450 xx	2"	22.0	260	367	450	581	822	80	183		70
		•	3680 xx	2 1/2"	26.0	393	555	680	878	1242	90	223		85
		•	3980 xx	3"	31.0	566	800	980	1265	1789	105	268		100

### SPRAY ANGLE 30°

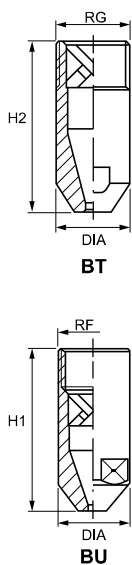

BRF Female	BSF Male	BTF Male	Code	RF RG inch	D mm	Capacity at different pressure values (l/min) (bar)					Dimension mm			
						1.0	2.0	3.0	5.0	10	DIA	H1	H2	WS
•	•		0980 xx	1/8"	1.0	0.57	0.80	0.98	1.27	1.79		33	35	12
•	•		1160 xx	1/8"	1.2	0.92	1.31	1.60	2.07	2.92				
•	•		1270 xx	1/8"	1.6	1.56	2.20	2.70	3.49	4.93				
•	•		1350 xx	1/4"	1.8	2.02	2.86	3.50	4.52	6.39		44	44	17
•	•		1550 xx	3/8"	2.3	3.18	4.49	5.50	7.10	10.0		53	53	22
•	•		2117 xx	1/2"	3.2	6.75	9.55	11.7	15.1	21.4		72	72	24
•	•		2195 xx	3/4"	4.2	11.3	15.9	19.5	25.2	35.6		84	87	25
		•	2270 xx	1"	5.1	15.6	22.0	27.0	34.9	49.3	34		92	35
		•	2390 xx	1"	6.1	22.5	31.8	39.0	50.3	71.2				
		•	2590 xx	1 1/4"	7.4	34.1	48.2	59.0	76.2	108	42		117	40
		•	2780 xx	1 1/4"	8.6	45.0	63.7	78.0	101	142				
		•	2980 xx	1 1/2"	9.6	56.6	80.0	98.0	127	179	48		127	52
		•	3117 xx	1 1/2"	10.5	67.5	95.5	117	151	214				
		•	3137 xx	2"	11.1	79.1	112	137	177	250	60		200	55
		•	3156 xx	2"	11.9	90.1	127	156	201	285				
		•	3195 xx	2"	13.5	113	159	195	252	356				
		•	3235 xx	2 1/2"	14.7	136	192	235	303	429	70		254	60
		•	3275 xx	2 1/2"	15.9	159	225	275	355	502				
		•	3390 xx	2 1/2"	19.1	225	318	390	503	712				
		•	3430 xx	2 1/2"	19.8	248	351	430	555	785				
		•	3470 xx	2 1/2"	20.6	271	384	470	607	858				

#### HOW TO MAKE UP THE NOZZLE CODE

EX.: BRB 1270 B1

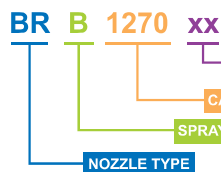

- **B1** - AISI 303 Stainless steel
- **B31** - AISI 316L Stainless steel
- **T1** - Brass
- **E1** - PTFE
- **D1** - PVC
- **D2** - Polypropylene

**OFF LINE SPRAY**

BV/BW series are two-piece nozzles with a 90° elbow coupling that produce a mist spray. Their special design with X-vane breaks the liquid into fine droplets and allows an easy cleaning. They may be supplied with male or female threaded connections. See below table.



- **Thread specification**
- Male ( BSPT, NPT )
- Female ( BSP, NPT )

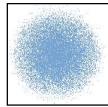

Spray section

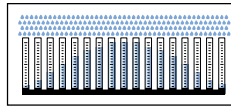

Convex distribution

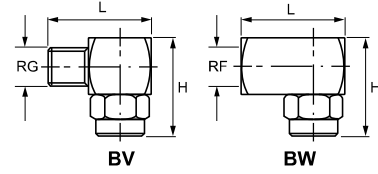

**SPRAY ANGLE 60°**

60°	BVQ Male	BWQ Female	Code	RF RG inch	Capacity at different pressure values (l/min) (bar)						Dimension mm		
					0.5	1.0	2.0	3.0	5.0	10	H	L	
• • • • •	• • • • •	• • • • •	1150 xx	1/8"	0.61	0.87	1.22	1.50	1.94	2.74	24	24.5	
			1220 xx		0.90	1.27	1.80	2.20	2.84	4.02			
			1260 xx		1.06	1.50	2.12	2.60	3.36	4.75			
			1290 xx		1.18	1.67	2.37	2.90	3.74	5.29			
			1370 xx		1.51	2.14	3.02	3.70	4.78	6.76			
	1450 xx	1.84	2.60	3.67	4.50	5.81	8.22						
	• • • • •	• • • • •	1480 xx	1/4"	1.96	2.77	3.92	4.80	6.20	8.76	32	32.0	
					1740 xx	3.02	4.27	6.04	7.40	9.55			13.5
					1930 xx	3.80	5.37	7.59	9.30	12.0			17.0
	• • • • •	• • • • •	1700 xx	3/8"	2.86	4.04	5.72	7.00	9.04	12.8	35	32.5	
					2111 xx	4.53	6.41	9.06	11.1	14.3			20.3
					2144 xx	5.88	8.31	11.8	14.4	18.6			26.3
2163 xx					6.65	9.41	13.3	16.3	21.0	29.8			
2118 xx					4.82	6.81	9.63	11.8	15.2	21.5			
• • • • •	• • • • •	2185 xx	1/2"	7.55	10.7	15.1	18.5	23.9	33.8	50	40.0		
				2240 xx	9.80	13.9	19.6	24.0	31.0			43.8	
				2300 xx	12.3	17.3	24.5	30.0	38.7			54.8	
				2360 xx	14.7	20.8	29.4	36.0	46.5			65.7	

**SPRAY ANGLE 120°**

120°	BVW Male	BWW Female	Code	RF RG inch	Capacity at different pressure values (l/min) (bar)						Dimension mm	
					0.5	1.0	2.0	3.0	5.0	10	H	L
• • • • •	• • • • •	• • • • •	1310 xx	1/8"	1.27	1.79	2.53	3.10	4.00	5.66	24	24.5
			1570 xx		2.33	3.29	4.65	5.70	7.36	10.4		
	• • • • •	• • • • •	2100 xx	1/4"	4.08	5.77	8.16	10.0	12.9	18.3	32	32.0
					2144 xx	5.88	8.31	11.8	14.4	18.6		
	• • • • •	• • • • •	2250 xx	1/2"	10.2	14.4	20.4	25.0	32.3	45.6	50	40.0
					2360 xx	14.7	20.8	29.4	36.0	46.5		

**Typical applications**

- Washing**
- Parts washing
- Gas scrubbing
- Food washing
- Cooling**
- Parts cooling
- Gas cooling
- Tank cooling

**HOW TO MAKE UP THE NOZZLE CODE**

EX.: BVQ 1150 B1

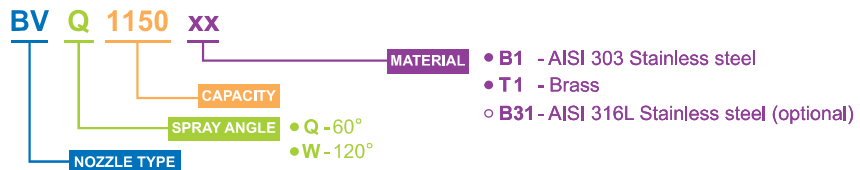

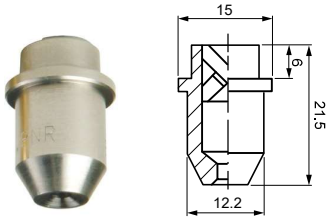

Above is outer shape of BX 1149 - BX 1372

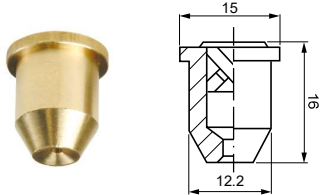

Above is outer shape of BX 1508 - BX 1743

### NOZZLE TIPS

BX full cone tips produce a uniform full cone shaped spray with a round impact area. Thanks to their design they can be easily disassembled and cleaned in case of clogging. These nozzles have an X-vane safely secured inside their body up to 3/8" thread size.

#### Typical applications

**Washing:** steel cleaning, parts cleaning, pre-treatment for coating process

**Cooling:** continuous casting cooling, product cooling, tank cooling

**Dust control:** dust removal in mining and coal plants

**Other applications:** spray of chemicals, leak test



Spray section

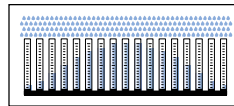

Convex distribution

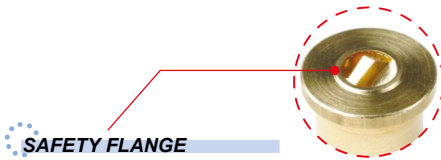

### SAFETY FLANGE

In continuous casting cooling and other specific applications, nozzles are often positioned to spray upwards and must operate at very high temperatures. This may cause both thermal expansion and shrinkage of the nozzle vane due to temperature changes. The X-type vanes are designed to endure such temperature variations and to avoid the risk of escaping from the nozzle body in case of pump shut downs in vacuum conditions. All PNR full cone nozzles with X-vane (and thread size smaller than 3/8") have a protection flange to secure their vanes in place.

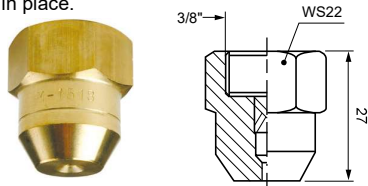

BJ

### ASSEMBLY ACCESSORIES

In most steelworks applications, BX series nozzles are provided with a welding nipple and locknut for the assembly of related accessories. Please see on page 44 for detailed information.



ZAA C018 xxG



VAA 0380 xx

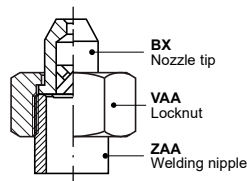

Code	D mm	Capacity (l/min) at different pressure values (bar)					Spray angle at pressure (°) (bar)			
		1.0	2.0	3.0	5.0	10	1.5	3.0	5.0	
60°	<b>BXQ 1149 xx</b>	1.3	0.86	1.22	1.49	1.92	2.72	50°	50°	45°
	<b>BXQ 1223 xx</b>	1.7	1.29	1.82	2.23	2.88	4.07	65°	65°	49°
	<b>BXQ 1262 xx</b>	1.7	1.51	2.14	2.62	3.38	4.78	50°	50°	46°
	<b>BXQ 1372 xx</b>	2.1	2.15	3.04	3.72	4.80	6.79	65°	65°	59°
	<b>BXQ 1508 xx</b>	2.4	2.93	4.15	5.08	6.56	9.27	50°	50°	46°
	<b>BXQ 1626 xx</b>	2.9	3.61	5.11	6.26	8.08	11.4	60°	60°	55°
	<b>BXQ 1743 xx</b>	2.9	4.29	6.07	7.43	9.59	13.6	67°	67°	61°

### SISTER PRODUCTS / THREAD SIZE

As for the BX series full cone nozzles, sister products with a 3/8" female thread are also available. In the steel industry spraying nozzles fixed on the water pipes can be easily damaged during the manufacturing process. PNR can offer the ideal solution to this problem, the BJ series nozzles designed according to customers' requirements. If welded tips are out of use, you can use BJ nozzles instead of BX. They have the same technical features and jet length.

Simply change the product code as follows, e.g. **BXQ 1372 T1** → **BJQ 1372 T1**

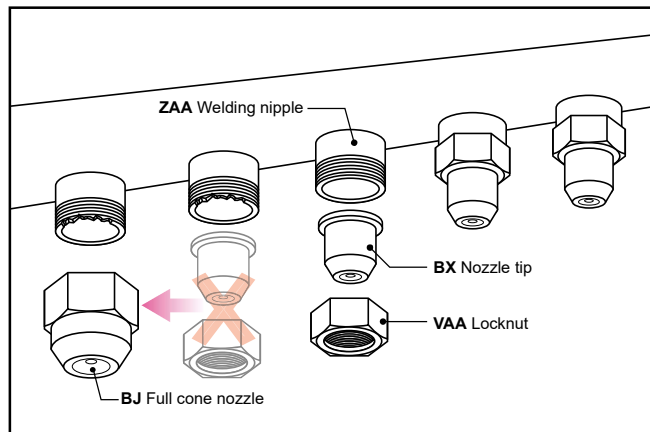

### HOW TO MAKE UP THE NOZZLE CODE

EX.: BXQ 1149 B1

**BX** **Q** **1149** **xx**

NOZZLE TYPE

CAPACITY

SPRAY ANGLE • Q - 60°

MATERIAL

• B1 - AISI 303 Stainless steel

• T1 - Brass

• B31 - AISI 316L Stainless steel (optional)

CLUSTER NOZZLES / TYPE 7 AND 13

CH series includes large and small capacities hollow cone cluster nozzles. They make a cluster spray pattern and are available in 7 and 13 nozzles versions. Several nozzles are assembled on one nipple with small volume and wide spray coverage. The droplets size is 1/3-1/2 compared to those produced by a single nozzle with same capacity. An added value to CH nozzles is their wide spray range.



▪ Thread specification: BSP, NPT

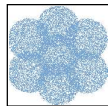

Spray section

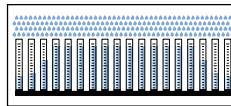

Even distribution

Spray Angle	Code	RF inch	D inch	Capacity at different pressure values (l/min) (bar)					Dimensions mm				NR
				1.0	2.0	3.0	5.0	10	D	D1	H	H1	
200°	CHZ 1826 xx	3/4"	1/8"	4.77	6.47	8.26	10.7	15.1	71	40	55	13	7
	CHZ 2165 xx			9.53	13.5	16.5	21.3	30.1					
	CHZ 2329 xx	1"	1/4"	19.0	26.9	32.9	42.5	60.1	89	46	68	17	
	CHZ 2585 xx			33.8	47.8	58.5	75.5	106.8					
	CHZ 2819 xx			47.3	66.9	81.9	105.7	149.5					
	CHZ 3102 xx	1 1/2"	3/8"	59.4	84.0	102.9	132.8	187.9	128	70	93	20	
	CHZ 3131 xx			76.0	107.5	131.6	169.9	240.3					
360°	CHZ 3206 xx	2"	1/2"	119.2	168.6	206.5	266.6	377.0	171	85	122	27	
	CHZ 3259 xx		3/4"	149.5	211.5	259.0	334.4	472.9					
	CHZ 3329 xx			189.9	268.6	329.0	424.7	600.7					
	CHE 2153 xx	3/4"	1/8"	8.83	12.5	15.3	19.8	27.9	69	39	85	-	13
	CHE 2306 xx			17.7	25.0	30.6	39.5	55.9					
	CHE 2611 xx	1"	1/4"	35.3	49.9	61.1	78.9	111.6	86	48	105	-	
	CHE 3108 xx			62.7	88.7	108.6	140.2	198.3					
	CHE 3152 xx			87.8	124.2	152.1	196.4	277.7					
	CHE 3191 xx	1 1/2"	3/8"	110.3	156.0	191.1	246.7	348.9	98	55	120	-	
	CHE 3245 xx			141.5	200.0	245.0	316.3	447.3					
CHE 3383 xx	2"	1/2"	221.4	313.1	383.5	495.1	700.2	129	73	158	-		
CHE 3481 xx		3/4"	277.7	392.7	481.0	621.0	878.2	169	95	206	-		

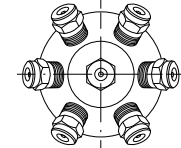
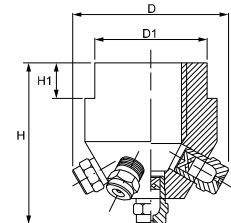

Cluster nozzle 7 nozzles type

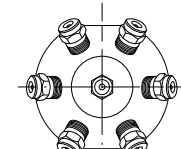
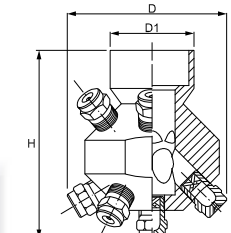

Cluster nozzle 13 nozzles type

You can go with other full cone nozzle in addition to standard capacity. Please contact us.

Typical applications

- Cooling: gas cooling
- Washing: tank cleaning, gas cleaning
- Other applications: fire engineering, dust control, wetting



HOW TO MAKE UP THE NOZZLE CODE

EX.: CHZ 1826 B1

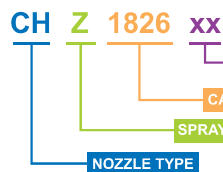

- MATERIAL
- B1 - AISI 303 Stainless steel
  - B31 - AISI 316L Stainless steel
  - T1 - Brass

- SPRAY ANGLE
- Z - 200°
  - E - 360°



## CLUSTER NOZZLE / STANDARD SPRAY ANGLE

CAS cluster nozzles have seven orifices, large spray capacities and produce very fine droplets using hydraulic pressure only. As the droplets size, among other factors, also depends on the nozzle size, these multi-orifice nozzles produce a finer spray than a standard full cone single-orifice nozzle working at the same pressure and delivering the same quantity of liquid. The surely are the best choice when fine mist effect and large spray capacity are required.

### Typical applications

#### Cooling

cooling of high-temperature gas

#### Fire control

watermist fire suppression systems

#### Other applications

exhaust gas treatment, dust control, wetting

### Thread specification: BSP, NPT

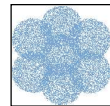
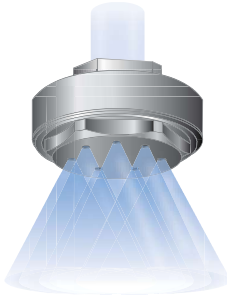
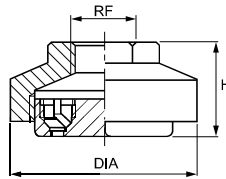

Spray section

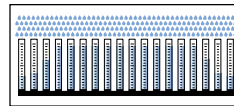

Even distribution



70°	Code	RF inch	D mm	D1 mm	Capacity at different pressure values (l/min) (bar)							Dimensions mm		
					0.7	1.0	1.5	2.0	3.0	5.0	10	NR	DIA	H
70°	CAS 1153 xx	1/2"	0.9	0.5	0.74	0.88	1.08	1.25	1.53	1.98	2.79	7	50	33.5
	CAS 1274 xx		1.8	0.5	1.32	1.58	1.94	2.24	2.74	3.54	5.00			
	CAS 1343 xx	3/4"	1.1	1.0	1.66	1.98	2.43	2.80	3.43	4.43	6.26	7	72	43
	CAS 1551 xx		1.5	1.4	2.66	3.18	3.90	4.50	5.51	7.11	10.1			
	CAS 1870 xx		2.1	2.0	4.20	5.02	6.15	7.10	8.70	11.2	15.9			
	CAS 2116 xx		2.5	2.0	5.60	6.70	8.20	9.47	11.6	15.0	21.2			
	CAS 2145 xx		3.0	2.0	7.00	8.37	10.3	11.8	14.5	18.7	26.5			
	CAS 2184 xx		3.5	2.0	8.89	10.6	13.0	15.0	18.4	23.8	33.6			
	CAS 2220 xx		4.0	2.0	10.6	12.7	15.6	18.0	22.0	28.4	40.2			
	CAS 2342 xx		3.5	2.0	16.5	19.8	24.2	27.9	34.2	44.2	62.4			
	CAS 2434 xx		4.0	2.0	21.0	25.1	30.7	35.4	43.4	56.0	79.2			
	CAS 2551 xx		5.0	2.0	26.6	31.8	39.0	45.0	55.1	71.1	101			
	CAS 2728 xx		6.0	2.0	35.2	42.0	51.5	59.4	72.8	94.0	133			
	CAS 2385 xx	1"	5.0	2.5	18.6	22.2	27.2	31.4	38.5	49.7	70.3	7	140	74
	CAS 2489 xx		6.5	2.5	23.6	28.2	34.6	39.9	48.9	63.1	89.3			
CAS 2685 xx		8.0	2.5	33.1	39.6	48.4	55.9	68.5	88.4	125				
CAS 3130 xx	2"	9.0	5.0	62.8	75.1	91.9	106	130	168	237	7	185	103	
CAS 3184 xx		12.0	5.0	88.9	106	130	150	184	238	336				
CAS 3245 xx		15.0	5.0	118	142	173	200	245	316	447				

NR - Number of orifices

### HOW TO MAKE UP THE NOZZLE CODE

EX.: CAS 1153 B31

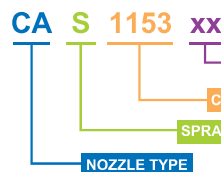

#### MATERIAL

- B1 - AISI 303 Stainless steel
- B31 - AISI 316L Stainless steel
- T1 - Brass
- T8 - Nickel plated brass

#### CAPACITY

• S - 70°

#### NOZZLE TYPE

**CLUSTER NOZZLE / WIDE SPRAY ANGLE**

CAY cluster full cone nozzles produce very fine droplets using hydraulic pressure only. They provide large spray capacities, mist effect and a 130° spray angle with wider coverage. CAY nozzles have 7 orifices that, at the same operating pressure and using the same quantity of liquid, produce a finer spray than standard full cone nozzles with one orifice only. They are the best choice when large spray capacities and mist effect are required.

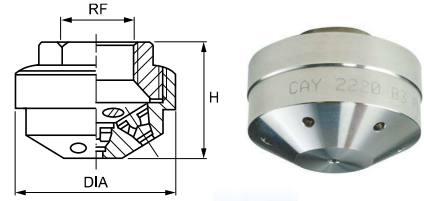

FULL CONE NOZZLES



■ Thread specification: BSP, NPT

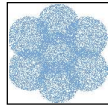

Spray section

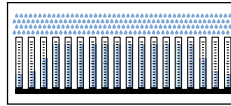

Even distribution



130°	Code	RF inch	D mm	D1 mm	Capacity at different pressure values							Dimensions mm		
					0.7	1.0	1.5	2.0	3.0	5.0	10	NR	DIA	H
	CAY 1153 xx	1/2"	1.0	0.5	0.74	0.88	1.08	1.25	1.53	1.98	2.79	7	40	33.5
	CAY 1274 xx				1.32	1.58	1.94	2.24	2.74	3.54	5.00			
	CAY 1343 xx	3/4"	1.0	1.0	1.66	1.98	2.43	2.80	3.43	4.43	6.26	7	63	46.0
	CAY 1551 xx				2.66	3.18	3.90	4.50	5.51	7.11	10.1			
	CAY 1870 xx				4.20	5.02	6.15	7.10	8.70	11.2	15.9			
	CAY 2116 xx				5.60	6.70	8.20	9.47	11.6	15.0	21.2			
	CAY 2145 xx				7.00	8.37	10.3	11.8	14.5	18.7	26.5			
	CAY 2184 xx				8.89	10.6	13.0	15.0	18.4	23.8	33.6			
	CAY 2220 xx				10.6	12.7	15.6	18.0	22.0	28.4	40.2			
	CAY 2342 xx				16.5	19.8	24.2	27.9	34.2	44.2	62.4			
	CAY 2434 xx				21.0	25.1	30.7	35.4	43.4	56.0	79.2			
	CAY 2551 xx				26.6	31.8	39.0	45.0	55.1	71.1	101			
CAY 2728 xx	35.2	42.0	51.5	59.4	72.8	94.0	133							
	CAY 2385 xx	1"	5.0	3.2	18.6	22.2	27.2	31.4	38.5	49.7	70.3	7	120	81.0
	CAY 2489 xx				23.6	28.2	34.6	39.9	48.9	63.1	89.3			
	CAY 2685 xx				33.1	39.6	48.4	55.9	68.5	88.4	125			
	CAY 2979 xx				47.3	56.5	69.2	79.9	97.9	126	179			
	CAY 3137 xx				66.2	79.1	96.9	112	137	177	250			
	CAY 3130 xx				62.8	75.1	91.9	106	130	168	237			
	CAY 3184 xx	2"	12.0	3.2	88.9	106	130	150	184	238	336	7	155	104.5
	CAY 3245 xx				118	142	173	200	245	316	447			
	CAY 3260 xx				126	150	184	212	260	336	475			
	CAY 3367 xx				177	212	260	300	367	474	670			
	CAY 3490 xx				237	283	346	400	490	633	895			

NR - Number of orifices

**Typical applications**

- Cooling:** cooling of high-temperature gas
- Washing:** tank cleaning, parts cleaning
- Fire control:** water mist fire suppression systems
- Other applications:** exhaust gas treatment, dust control, wetting

**HOW TO MAKE UP THE NOZZLE CODE**

EX.: CAY 1153 B1



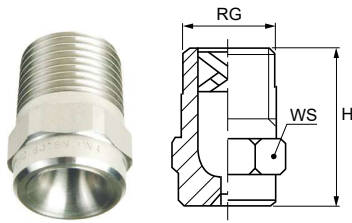

### X VANE / TWO-PIECE DESIGN

D series full cone nozzles with wide passage X-vanes offer a full choice of spray angles, capacities ranging from 1.18 and 1.420 l/min and connections from 1/8" to 4".

In continuous casting cooling and other specific applications, they are used spraying upwards and operate at very high temperatures. The X-vane is safely locked into place for all dimensions up to 3/8", to avoid it may escape from the nozzle body in case of size changes due to temperature variations, and allows to assemble the nozzle with any desired orientation. Excellent mist effect and a wide variety of applications make D series nozzles an optimal choice.

- Thread specification: BSPT, NPT

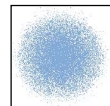

Spray section

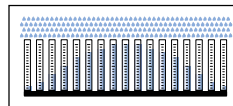

Convex distribution



#### Thread size coding table

RG	Code	H	WS
inch		mm	mm
1/8"	DA	19.5	12.0
1/4"	DB	22.0	14.0
3/8"	DC	25.0	17.0
1/2"	DD	33.0	22.0

#### How to make up the nozzle code

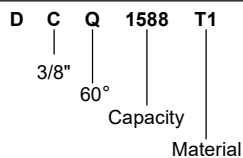

### SPRAY ANGLE 45°

Nozzle type				Code	D mm	D1 mm	Capacity (l/min) at different pressure values (bar)						
DAM	DBM	DCM	DDM				0.7	1.0	2.0	3.0	5.0	7.0	10
•	•						0780 xx	1.0	0.5	0.38	0.45	0.64	0.78
•	•			1118 xx	1.1	1.0	0.57	0.68	0.96	1.18	1.52	1.80	2.15
•	•			1147 xx	1.2	1.1	0.71	0.85	1.20	1.47	1.90	2.25	2.68
•	•			1188 xx	1.3	1.2	0.91	1.09	1.54	1.88	2.43	2.87	3.43
•	•			1212 xx	1.4	1.2	1.02	1.22	1.73	2.12	2.74	3.24	3.87
•	•	•		1235 xx	1.5	1.3	1.14	1.36	1.92	2.35	3.03	3.59	4.29
•	•	•		1294 xx	1.7	1.5	1.42	1.70	2.40	2.94	3.80	4.49	5.37
•	•	•		1370 xx	2.0	1.8	1.79	2.14	3.02	3.70	4.78	5.65	6.76
•	•	•	•	1470 xx	2.1	2.0	2.27	2.71	3.84	4.70	6.07	7.18	8.58
•	•	•	•	1588 xx	2.3	2.0	2.84	3.39	4.80	5.88	7.59	8.98	10.7
	•	•	•	1659 xx	2.5	2.2	3.18	3.80	5.38	6.59	8.51	10.1	12.0
		•	•	1740 xx	2.7	2.3	3.57	4.27	6.04	7.40	9.55	11.3	13.5
		•	•	1835 xx	2.8	2.6	4.03	4.82	6.82	8.35	10.8	12.8	15.2
		•	•	1940 xx	3.0	3.0	4.54	5.43	7.68	9.40	12.1	14.4	17.2
		•	•	2105 xx	3.2	3.2	5.07	6.06	8.57	10.5	13.6	16.0	19.2
		•	•	2117 xx	3.4	3.3	5.65	6.75	9.55	11.7	15.1	17.9	21.4
		•	•	2147 xx	3.8	3.7	7.10	8.49	12.0	14.7	19.0	22.5	26.8
		•	•	2188 xx	4.3	4.3	9.08	10.9	15.4	18.8	24.3	28.7	34.3
		•	•	2235 xx	5.0	4.5	11.4	13.6	19.2	23.5	30.3	35.9	42.9

### SPRAY ANGLE 60°

Nozzle type				Code	D mm	D1 mm	Capacity (l/min) at different pressure values (bar)						
DAQ	DBQ	DCQ	DDQ				0.7	1.0	2.0	3.0	5.0	7.0	10
•	•						0780 xx	1.0	0.5	0.38	0.45	0.64	0.78
•	•			1118 xx	1.2	0.8	0.57	0.68	0.96	1.18	1.52	1.80	2.15
•	•			1147 xx	1.3	1.0	0.71	0.85	1.20	1.47	1.90	2.25	2.68
•	•	•		1188 xx	1.4	1.1	0.91	1.09	1.54	1.88	2.43	2.87	3.43
•	•	•		1212 xx	1.5	1.2	1.02	1.22	1.73	2.12	2.74	3.24	3.87
•	•	•		1235 xx	1.6	1.2	1.14	1.36	1.92	2.35	3.03	3.59	4.29
•	•	•		1294 xx	1.8	1.3	1.42	1.70	2.40	2.94	3.80	4.49	5.37
•	•	•		1370 xx	2.0	1.4	1.79	2.14	3.02	3.70	4.78	5.65	6.76
•	•	•	•	1470 xx	2.4	1.9	2.27	2.71	3.84	4.70	6.07	7.18	8.58
	•	•	•	1588 xx	2.6	2.0	2.84	3.39	4.80	5.88	7.59	8.98	10.7
	•	•	•	1659 xx	2.7	2.0	3.18	3.80	5.38	6.59	8.51	10.1	12.0
	•	•	•	1740 xx	2.9	2.0	3.57	4.27	6.04	7.40	9.55	11.3	13.5
	•	•	•	1835 xx	3.2	2.8	4.03	4.82	6.82	8.35	10.8	12.8	15.2
	•	•	•	1940 xx	3.2	2.8	4.54	5.43	7.68	9.40	12.1	14.4	17.2
	•	•	•	2105 xx	3.4	3.0	5.07	6.06	8.57	10.5	13.6	16.0	19.2
	•	•	•	2117 xx	3.6	3.0	5.65	6.75	9.55	11.7	15.1	17.9	21.4
	•	•	•	2147 xx	4.0	3.3	7.10	8.49	12.0	14.7	19.0	22.5	26.8
	•	•	•	2188 xx	4.5	3.7	9.08	10.9	15.4	18.8	24.3	28.7	34.3
	•	•	•	2235 xx	5.2	4.5	11.4	13.6	19.2	23.5	30.3	35.9	42.9
	•	•	•	2294 xx	5.8	4.7	14.2	17.0	24.0	29.4	38.0	44.9	53.7

#### Typical applications

- Washing**
  - Food cleaning
  - Parts cleaning
  - Pre-treatment for coating process
- Cooling**
  - Continuous casting cooling
  - Product cooling
  - Tank cooling
- Dust control**
  - Remove flying dust in mining and coal plants.
- Other applications**
  - Spray of chemicals
  - Leak test

X VANE / TWO-PIECE DESIGN

SPRAY ANGLE 90°

Nozzle type				Code	D mm	D1 mm	Capacity at different pressures values (l/min) (bar)						
DAU	DBU	DCU	DDU				0.7	1.0	2.0	3.0	5.0	7.0	10
•				0780 XX	1.0	0.5	0.38	0.45	0.64	0.78	1.01	1.19	1.42
•				1118 XX	1.2	0.8	0.57	0.68	0.96	1.18	1.52	1.80	2.15
•	•			1147 XX	1.3	1.0	0.71	0.85	1.20	1.47	1.90	2.25	2.68
•	•			1188 XX	1.4	1.2	0.91	1.09	1.54	1.88	2.43	2.87	3.43
•	•			1212 XX	1.5	1.2	1.02	1.22	1.73	2.12	2.74	3.24	3.87
•	•	•		1235 XX	1.6	1.3	1.14	1.36	1.92	2.35	3.03	3.59	4.29
•	•	•		1294 XX	1.8	1.3	1.42	1.70	2.40	2.94	3.80	4.49	5.37
•	•	•		1370 XX	2.0	1.4	1.79	2.14	3.02	3.70	4.78	5.65	6.76
	•	•		1470 XX	2.3	1.8	2.27	2.71	3.84	4.70	6.07	7.18	8.58
	•	•		1588 XX	2.6	1.8	2.84	3.39	4.80	5.88	7.59	8.98	10.7
	•	•		1659 XX	2.7	2.0	3.18	3.80	5.38	6.59	8.51	10.1	12.0
	•	•		1740 XX	2.9	2.0	3.57	4.27	6.04	7.40	9.55	11.3	13.5
	•	•		1835 XX	3.3	2.0	4.03	4.82	6.82	8.35	10.8	12.8	15.2
	•	•		1940 XX	3.3	2.4	4.54	5.43	7.68	9.40	12.1	14.4	17.2
	•	•		2105 XX	3.5	2.6	5.07	6.06	8.57	10.5	13.6	16.0	19.2
		•		2117 XX	3.7	2.7	5.65	6.75	9.55	11.7	15.1	17.9	21.4
		•		2147 XX	4.0	3.2	7.10	8.49	12.0	14.7	19.0	22.5	26.8
		•		2164 XX	4.1	3.2	7.92	9.47	13.4	16.4	21.2	25.1	29.9
			•	2188 XX	4.7	3.2	9.08	10.9	15.4	18.8	24.3	28.7	34.3
			•	2235 XX	5.2	3.8	11.4	13.6	19.2	23.5	30.3	35.9	42.9
			•	2294 XX	5.8	3.8	14.2	17.0	24.0	29.4	38.0	44.9	53.7
			•	2370 XX	6.4	3.8	17.9	21.4	30.2	37.0	47.8	56.5	67.6

SPRAY ANGLE 120°

Nozzle type				Code	D mm	D1 mm	Capacity at different pressures values (l/min) (bar)						
DAW	DBW	DCW	DDW				0.7	1.0	2.0	3.0	5.0	7.0	10
•				0780 XX	1.0	0.5	0.38	0.45	0.64	0.78	1.01	1.19	1.42
•	•			1118 XX	1.2	0.8	0.57	0.68	0.96	1.18	1.52	1.80	2.15
•	•			1147 XX	1.3	0.9	0.71	0.85	1.20	1.47	1.90	2.25	2.68
•	•			1188 XX	1.5	1.0	0.91	1.09	1.54	1.88	2.43	2.87	3.43
•	•			1212 XX	1.6	1.1	1.02	1.22	1.73	2.12	2.74	3.24	3.87
•	•			1235 XX	1.6	1.2	1.14	1.36	1.92	2.35	3.03	3.59	4.29
•	•			1294 XX	1.9	1.3	1.42	1.70	2.40	2.94	3.80	4.49	5.37
•	•			1370 XX	2.1	1.4	1.79	2.14	3.02	3.70	4.78	5.65	6.76
	•	•		1470 XX	2.4	1.6	2.27	2.71	3.84	4.70	6.07	7.18	8.58
	•	•		1588 XX	2.7	1.8	2.84	3.39	4.80	5.88	7.59	8.98	10.7
	•	•		1659 XX	3.0	1.8	3.18	3.80	5.38	6.59	8.51	10.1	12.0
	•	•		1740 XX	3.1	1.9	3.57	4.27	6.04	7.40	9.55	11.3	13.5
	•	•		1835 XX	3.3	1.9	4.03	4.82	6.82	8.35	10.8	12.8	15.2
	•	•		1940 XX	3.5	1.9	4.54	5.43	7.68	9.40	12.1	14.4	17.2
	•	•		2105 XX	3.7	2.3	5.07	6.06	8.57	10.5	13.6	16.0	19.2
		•		2117 XX	3.8	2.4	5.65	6.75	9.55	11.7	15.1	17.9	21.4
		•		2147 XX	4.2	2.7	7.10	8.49	12.0	14.7	19.0	22.5	26.8
		•		2164 XX	4.4	2.7	7.92	9.47	13.4	16.4	21.2	25.1	29.9
		•		2188 XX	4.6	3.1	9.08	10.9	15.4	18.8	24.3	28.7	34.3
		•		2235 XX	5.3	3.3	11.4	13.6	19.2	23.5	30.3	35.9	42.9
		•		2294 XX	5.9	4.1	14.2	17.0	24.0	29.4	38.0	44.9	53.7
		•		2370 XX	6.6	4.7	17.9	21.4	30.2	37.0	47.8	56.5	67.6

**X vane**

X vanes are widely used, mainly in steelworks. Their simple design is based on two sloping flat surfaces which induce a rotation of the liquid going through the nozzle, and two small slots on each flat part to produce a full-cone spray pattern.

All vanes are secured inside the nozzle body to prevent their moving in case of size changes due to high temperatures or sudden vacuum conditions in the feed pipe.

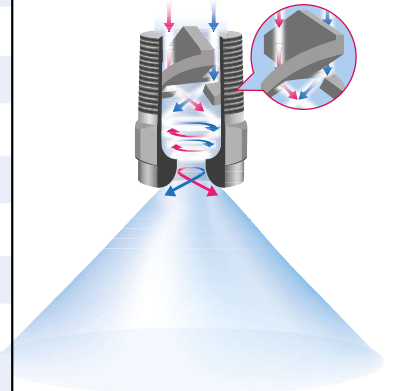

HOW TO MAKE UP THE NOZZLE CODE

EX.: DAU 1118 B1

**DAU 1118 XX**

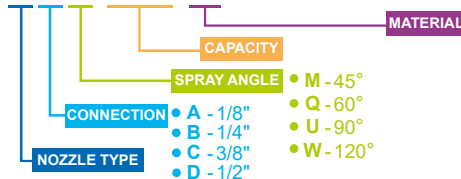

- B1 - AISI 303 Stainless steel
- B31 - AISI 316L Stainless steel
- T1 - Brass
- On request special materials are quoted



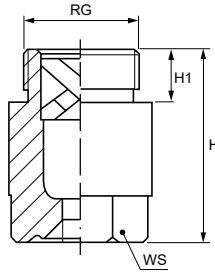

### X VANE / TWO-PIECE DESIGN / LARGE CAPACITY

D series full cone nozzles with large capacity are widely used in industry. They provide uniform spray coverage and are available in various thread sizes, spray angles and capacities to comply with environmental requirements. Their X-vane offers the largest free passage available in a nozzle, for an easier handling of the suspended particles and a higher resistance to clogging. D nozzles provide an optimal mist effect and are effective in many industrial applications.

- **Thread specification**  
BSPT, NPT (on request)

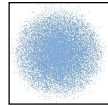

Spray section

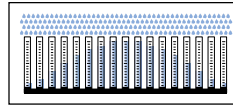

Convex distribution



60°	Code	RG inch	D mm	D1 mm	Capacity at different pressure values (l/min) (bar)							Dimension mm		
					0.7	1.0	2.0	3.0	5.0	7.0	10	H	H1	WS
	DEQ 2235 xx	3/4"	4.8	3.5	11.4	13.6	19.2	23.5	30.3	35.9	42.9	43	16	27
	DEQ 2295 xx		5.5	4.5	14.2	17.0	24.1	29.5	38.1	45.1	53.9			
	DEQ 2370 xx		6.0	4.5	17.9	21.4	30.2	37.0	47.8	56.5	67.6			
	DEQ 2470 xx		7.0	4.5	22.7	27.1	38.4	47.0	60.7	71.8	85.8			
	DFQ 2470 xx	1"	7.0	5.6	22.7	27.1	38.4	47.0	60.7	71.8	85.8	58	18	36
	DFQ 2590 xx		7.8	5.6	28.5	34.1	48.2	59.0	76.2	90.1	108			
	DFQ 2740 xx		9.5	5.6	35.7	42.7	60.4	74.0	95.5	113	135			
	DGQ 2740 xx	1 1/4"	9.5	5.6	35.7	42.7	60.4	74.0	95.5	113	135	74	19	41
	DGQ 3118 xx		12.5	6.0	57.0	68.1	96.3	118	152	180	215			
	DGQ 3147 xx		16.7	6.0	71.0	84.9	120	147	190	225	268			
	DHQ 3147 xx	1 1/2"	13.0	9.0	71.0	84.9	120	147	190	225	268	85	19	50
	DKQ 3188 xx	2"	15.0	9.0	90.8	109	154	188	243	287	343	106	24	60
	DKQ 3235 xx		16.0	11.0	114	136	192	235	303	359	429			
	DKQ 3294 xx		17.0	11.1	142	170	240	294	380	449	537			
	DLQ 3370 xx	2 1/2"	17.5	11.1	179	214	302	370	478	565	676	128	27	75
	DLQ 3470 xx		23.0	11.1	227	271	384	470	607	718	858			
	DMQ 3588 xx	3"	28.0	14.3	284	339	480	588	759	898	1074	153	30	85
	DNQ 3740 xx	3 1/2"	29.0	17.5	357	427	604	740	955	1130	1351	190	32	105
	DNQ 3940 xx		36.0	17.5	454	543	768	940	1214	1436	1716			
	DPQ 4117 xx	4"	39.0	19.0	568	678	959	1175	1517	1795	2145	205	36	110

90°	Code	RG inch	D mm	D1 mm	Capacity at different pressure values (l/min) (bar)							Dimension mm		
					0.7	1.0	2.0	3.0	5.0	7.0	10	H	H1	WS
	DEU 2295 xx	3/4"	5.8	3.0	14.2	17.0	24.1	29.5	38.1	45.1	53.9	43	16	27
	DEU 2370 xx		6.4	4.5	17.9	21.4	30.2	37.0	47.8	56.5	67.6			
	DEU 2470 xx		8.0	4.5	22.7	27.1	38.4	47.0	60.7	71.8	85.8			
	DEU 2590 xx		9.7	4.5	28.5	34.1	48.2	59.0	76.2	90.1	108			
	DFU 2590 xx	1"	8.6	4.5	28.5	34.1	48.2	59.0	76.2	90.1	108	58	18	36
	DFU 2740 xx		9.3	5.0	35.7	42.7	60.4	74.0	95.5	113	135			
	DFU 2830 xx		9.9	6.0	40.3	48.2	68.2	83.5	108	128	152			
	DGU 3118 xx	1 1/4"	13.0	6.0	57.0	68.1	96.3	118	152	180	215	74	19	41
	DGU 3147 xx		16.0	6.0	71.0	84.9	120	147	190	225	268			
	DHU 3147 xx	1 1/2"	16.0	6.0	71.0	84.9	120	147	190	225	268	85	19	50
	DHU 3188 xx		14.5	9.0	90.8	109	154	188	243	287	343			
	DKU 3235 xx	2"	16.6	11.0	114	136	192	235	303	359	429	106	24	60
	DKU 3294 xx		18.0	11.0	142	170	240	294	380	449	537			
	DKU 3370 xx		25.0	11.0	179	214	302	370	478	565	676			
	DLU 3470 xx	2 1/2"	27.0	11.1	227	271	384	470	607	718	858	128	27	75
	DLU 3588 xx		30.0	14.3	284	339	480	588	759	898	1074			
	DMU 3740 xx	3"	30.0	17.5	357	427	604	740	955	1130	1351	153	30	85
	DMU 3870 xx		32.5	17.5	420	502	710	870	1123	1329	1588			
	DNU 3940 xx	3 1/2"	35.5	17.5	454	543	768	940	1214	1436	1716	190	32	105
	DNU 4117 xx		39.0	19.0	568	678	959	1175	1517	1795	2145			
	DPU 4147 xx	4"	42.8	25.4	710	849	1200	1470	1898	2245	2684	205	36	110

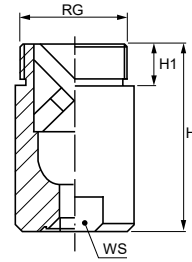

FULL CONE NOZZLES

120°	Code	RG inch	D mm	D1 mm	Capacity at different pressure values (l/min) (bar)								Dimension mm		
					0.7	1.0	2.0	3.0	5.0	7.0	10	H	H1	WS	
120°	DEW 2295 xx	3/4"	5.1	3.0	14.2	17.0	24.1	29.5	38.1	45.1	53.9	43	16	27	
	DEW 2370 xx		6.5	3.5	17.9	21.4	30.2	37.0	47.8	56.5	67.6				
	DEW 2470 xx		8.5	4.5	22.7	27.1	38.4	47.0	60.7	71.8	85.8				
	DEW 2590 xx		9.2	4.5	28.5	34.1	48.2	59.0	76.2	90.1	108				
	DFW 2590 xx	1"	11.5	4.5	28.5	34.1	48.2	59.0	76.2	90.1	108	58	18	36	
	DFW 2740 xx		12.0	4.5	35.7	42.7	60.4	74.0	95.5	113	135				
	DFW 2830 xx		13.0	5.6	40.3	48.2	68.2	83.5	108	128	152				
	DGW 3118 xx	1 1/4"	13.5	6.0	57.0	68.1	96.3	118	152	180	215	74	19	41	
	DGW 3147 xx		17.0	6.0	71.0	84.9	120	147	190	225	268				
	DHW 3118 xx	1 1/2"	13.0	6.0	57.0	68.1	96.3	118	152	180	215	85	19	50	
	DHW 3188 xx		20.0	9.0	90.8	109	154	188	243	287	343				
	DKW 3235 xx	2"	18.0	11.0	114	136	192	235	303	359	429	106	24	60	
	DKW 3294 xx		19.0	11.0	142	170	240	294	380	449	537				
	DKW 3370 xx		21.3	11.0	179	214	302	370	478	565	676				
	DLW 3470 xx	2 1/2"	23.5	11.1	227	271	384	470	607	718	858	128	27	75	
	DLW 3588 xx		26.5	14.3	284	339	480	588	759	898	1074				
	DMW 3740 xx	3"	29.5	17.5	357	427	604	740	955	1130	1351	153	30	85	
	DMW 3870 xx		32.0	17.5	420	502	710	870	1123	1329	1588				
DNW 3940 xx	3 1/2"	33.5	17.5	454	543	768	940	1214	1436	1716	190	32	105		
DNW 4117 xx		37.0	19.0	568	678	959	1175	1517	1795	2145					
DPW 4147 xx	4"	42.0	25.4	710	849	1200	1470	1898	2245	2684	205	36	110		

**THREAD SIZE CODE (RG)**

DE	DF	DG	DH	DK	DL	DM	DN	DP
3/4"	1"	1 1/4"	1 1/2"	2"	2 1/2"	3"	3 1/2"	4"

**Typical applications**

**Washing:** food cleaning, parts cleaning, pre-treatment for coating process

**Cooling:** continuous casting cooling, product cooling, tank cooling

**Dust control:** dust suppression in mining and coal plants.

**Other applications:** spray of chemicals, leak test.

**HOW TO MAKE UP THE NOZZLE CODE**

EX.: DEQ 2235 B1

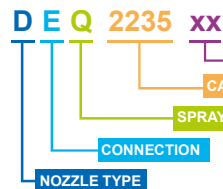

**MATERIAL**

• B1 - AISI 303 Stainless steel

• B31 - AISI 316L Stainless steel

• T1 - Brass

○ On request special materials are quoted

- Q - 60°
- U - 90°
- W - 120°



## STANDARD SPIRAL NOZZLES

E series spiral nozzles work on the impact principle, by the deflection of a water stream that impacts onto a spiral profiled surface which provides the desired spray angle. These are one-piece nozzles with no internal vane and a wider free passage. The liquid inlet has nearly the same size as the outlet orifice diameter. Their special design makes them virtually clog-free and produces a wider spray coverage than other nozzles for a given flow and pressure.

The capacity values on darker background can be obtained with metal nozzles only, plastic materials being too weak to assure structural nozzle resistance in harsh operating conditions. If the capacity values you are looking for are those on darker background, we recommend to chose metal nozzles for their longer operating life.

■ Thread specification: BSPT, NPT

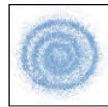

Spray section

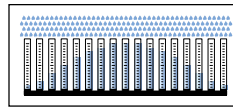

Convex distribution



- Typical applications**
- Gas cooling
  - Exhaust scrubbers
  - Desulfurization
  - Cooling
- Other applications**
- Spray of chemicals
  - Fire prevention and fire suppression

Spray Angle	Code	RG inch	D mm	D1 mm	Capacity at different pressure values (l/min) (bar)						Dimensions mm			
					0.7	1.0	2.0	3.0	5.0	7.0	10	H	H1	WS
60°	<b>EBQ 1550 xx</b>	1/4"	2.4	2.4	2.66	3.18	4.49	5.50	7.10	8.40	10.0	45	12	14
	<b>EBQ 2156 xx</b>		4.0	3.2	7.54	9.01	12.7	15.6	20.1	23.8	28.5			
	<b>ECQ 2230 xx</b>	3/8"	4.8	3.2	11.4	13.6	19.2	23.5	30.3	35.9	42.9	48	14	19
	<b>ECQ 2410 xx</b>		6.4	3.2	20.0	24.0	33.9	41.5	53.6	63.4	75.8			
	<b>ECQ 2640 xx</b>		7.9	3.2	31.2	37.3	52.7	64.6	83.4	99.0	118			
	<b>EDQ 2940 xx</b>	1/2"	9.5	4.7	45.6	54.5	77.1	94.4	122	144	172	64	18	22
	<b>EDQ 3128 xx</b>		11.1	4.7	61.8	73.9	105	128	165	196	234			
	<b>EEQ 3165 xx</b>	3/4"	12.7	4.7	79.7	95.3	135	165	213	252	301	70	19	27
	<b>EFQ 3260 xx</b>	1"	15.9	6.3	126	150	212	260	336	397	475	92	26	34
	<b>EFQ 3372 xx</b>		19.0	6.3	180	215	304	372	480	568	679			
90°	<b>EBU 1550 xx</b>	1/4"	2.4	2.4	2.66	3.18	4.49	5.50	7.10	8.40	10.0	45	12	14
	<b>EBU 2100 xx</b>		3.2	3.2	4.83	5.77	8.16	10.0	12.9	15.3	18.3			
	<b>EBU 2156 xx</b>		4.0	3.2	7.54	9.01	12.7	15.6	20.1	23.8	28.5			
	<b>ECU 2230 xx</b>	3/8"	4.8	3.2	11.4	13.6	19.2	23.5	30.3	35.9	42.9	48	14	19
	<b>ECU 2317 xx</b>		5.6	3.9	15.3	18.3	25.9	31.7	40.9	48.4	57.9			
	<b>ECU 2410 xx</b>		6.4	4.8	20.0	24.0	33.9	41.5	53.6	63.4	75.8			
	<b>ECU 2640 xx</b>		7.9	5.5	31.2	37.3	52.7	64.6	83.4	98.7	118			
	<b>EDU 2940 xx</b>	1/2"	9.5	3.3	45.6	54.5	77.1	94.4	122	144	172	64	18	22
	<b>EDU 3128 xx</b>		11.1	3.7	61.8	73.9	105	128	165	196	234			
	<b>EEU 3165 xx</b>	3/4"	12.7	4.7	79.7	95.3	135	165	213	252	301	70	19	27
90°	<b>EFU 3260 xx</b>	1"	19.0	6.3	126	150	212	260	336	397	475	92	26	34
	<b>EFU 3372 xx</b>		23.0	6.3	180	215	304	372	480	568	679			
	<b>EKU 4109 xx</b>	2"	34.9	11.1	527	629	890	1090	1407	1665	1990	149	31	65
	<b>EMU 4204 xx</b>	3"	44.5	14.3	985	1178	1666	2040	2634	3116	3725	219	42	89
	<b>EMU 4267 xx</b>		50.8		1290	1542	2180	2670	3447	4078	4875			

### THREAD SIZE CODE (RG)

EB	EC	ED	EE	EF	EH	EK	EM	EP
1/4"	3/8"	1/2"	3/4"	1"	1 1/2"	2"	3"	4"



### SPIRAL NOZZLES

The picture shows the inside of a spiral nozzle with a complete free passage without any internal vane. It has nearly the same size of liquid inlet and outlet orifice diameter to avoid clogging.

#### HOW TO MAKE UP THE NOZZLE CODE

EX.: EBQ 1550 B31

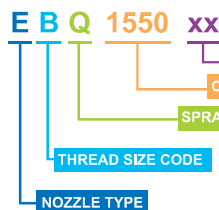

- B31 - AISI 316L Stainless steel
- T1 - Brass
- D1 - PVC
- D2 - PP
- D8 - PVDF
- E1 - PTFE
- L61 - Hastelloy C 22
- On request special materials are quoted

STANDARD SPIRAL NOZZLES

Code	RG inch	D mm	D1 mm	Capacity at different pressure values (l/min)							Dimension mm				
				0.7	1.0	2.0	3.0	5.0	7.0	10	(bar)	H	H1	WS	
120°	EBW 1550 xx	1/4"	2.4	2.4	2.66	3.18	4.49	5.50	7.10	8.40	10.0	45	12	14	
	EBW 2100 xx		3.2	3.2	4.83	5.77	8.16	10.0	12.9	15.3	18.3				
	EBW 2156 xx		4.0	3.2	7.54	9.01	12.7	15.6	20.1	23.8	28.5				
	ECW 2156 xx	3/8"	4.0	3.2	7.54	9.01	12.7	15.6	20.1	23.8	28.5	48	14	19	
	ECW 2230 xx		4.8	3.2	11.4	13.6	19.2	23.5	30.3	35.9	42.9				
	ECW 2317 xx		5.6	4.0	15.3	18.3	25.9	31.7	40.9	48.4	57.9				
	ECW 2410 xx		6.4	4.0	20.0	24.0	33.9	41.5	53.6	63.4	75.8				
	ECW 2640 xx		7.9	4.0	31.2	37.3	52.7	64.6	83.4	98.7	118				
	EDW 2940 xx	1/2"	9.5	4.8	45.6	54.5	77.1	94.4	122	144	172	64	18	22	
	EDW 3104 xx		9.7	4.8	50.2	60.0	84.9	104	134	159	190				
	EDW 3128 xx		11.1	4.8	61.8	73.9	105	128	165	196	234				
	EEW 3165 xx	3/4"	12.7	4.8	79.7	95.3	135	165	213	252	301	70	19	27	
	EFW 3260 xx	1"	15.9	6.3	126	150	212	260	336	397	475	92	26	34	
	EFW 3372 xx		19.0		180	215	304	372	480	568	679				
	EHW 3507 xx	1 1/2"	22.2	7.9	245	293	414	507	655	774	926	111	27	50	
	EHW 3663 xx		25.4		320	383	541	663	856	1013	1210				
	EHW 3747 xx		28.6		361	431	610	747	964	1141	1364				
	EKW 4109 xx	2"	34.9	11.1	527	629	890	1090	1407	1665	1990	149	31	65	
EKW 4139 xx		38.1		672	803	1136	1391	1796	2125	2540					
EMW 4204 xx	3"	44.5	14.3	985	1178	1666	2040	2634	3116	3725	203	35	90		
EMW 4265 xx		51.0		1280	1530	2164	2650	3421	4048	4838					
EPW 4412 xx	4"	63.5	15.9	1990	2379	3364	4120	5319	6293	7522	230	40	127		
150°	ECX 2230 xx	3/8"	4.8	3.2	11.4	13.6	19.2	23.5	30.3	35.9	42.9	48	14	19	
	ECX 2317 xx		5.6	4.0	15.3	18.3	25.9	31.7	40.9	48.4	57.9				
	ECX 2410 xx		6.4		20.0	24.0	33.9	41.5	53.6	63.4	75.8				
	ECX 2640 xx		7.9		31.2	37.3	52.7	64.6	83.4	98.7	118				
	EDX 2940 xx	1/2"	9.5	4.8	45.6	54.5	77.1	94.4	122	144	172	64	18	22	
	EDX 3128 xx		11.1		61.8	73.9	105	128	165	196	234				
	EEW 3165 xx	3/4"	12.7	4.8	79.7	95.3	135	165	213	252	301	70	19	27	
	EFX 3260 xx	1"	15.9	6.3	126	150	212	260	336	397	475	92	26	34	
	EFX 3372 xx		19.0		180	215	304	372	480	568	679				
	EHX 3507 xx	1 1/2"	22.2	7.9	245	293	414	507	655	774	926	111	27	50	
	EHX 3663 xx		25.4		320	383	541	663	856	1013	1210				
	EHX 3747 xx		28.6		361	431	610	747	964	1141	1364				
	EKX 4109 xx	2"	34.9	11.1	527	629	890	1090	1407	1665	1990	149	31	65	
	EKX 4139 xx		38.1		672	803	1136	1391	1796	2125	2540				
	180°	EBZ 2156 xx	1/4"	4.0	2.5	7.54	9.01	12.7	15.6	20.1	23.8	28.5	45	12	14
		ECZ 2230 xx	3/8"	4.8	3.2	11.4	13.6	19.2	23.5	30.3	35.9	42.9	48	14	19
		ECZ 2317 xx		5.6	4.0	15.3	18.3	25.9	31.7	40.9	48.4	57.9			
		ECZ 2410 xx		6.4		20.0	24.0	33.9	41.5	53.6	63.4	75.8			
ECZ 2640 xx			7.9		31.2	37.3	52.7	64.6	83.4	98.7	118				
EDZ 2940 xx		1/2"	9.5	3.3	45.6	54.5	77.1	94.4	122	144	172	64	18	22	
EDZ 3128 xx			11.1	4.8	61.8	73.9	105	128	165	196	234				
EEZ 3165 xx		3/4"	12.7	4.7	79.7	95.3	135	165	213	252	301	70	19	27	
EFZ 3260 xx		1"	15.9	6.3	126	150	212	260	336	397	475	92	25	36	
EFZ 3372 xx			19.0		180	215	304	372	480	568	679				
EHZ 3507 xx		1 1/2"	22.2	7.9	245	293	414	507	655	774	926	111	27	50	
EHZ 3663 xx			25.4		320	383	541	663	856	1013	1210				
EHZ 3747 xx			28.6		361	431	610	747	964	1141	1364				
EKZ 4109 xx		2"	34.9	11.1	527	629	890	1090	1407	1665	1990	149	31	63	
EKZ 4139 xx			38.1		671	803	1136	1391	1796	2125	2540				



THREAD SIZE CODE (RG)

EB	EC	ED	EE	EF	EH	EK	EM	EP
1/4"	3/8"	1/2"	3/4"	1"	1 1/2"	2"	3"	4"

HOW TO MAKE UP THE NOZZLE CODE

EX.: EBW 1550 B31

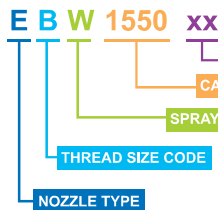

- Q - 60°
- U - 90°
- W - 120°
- X - 150°
- Z - 180°

MATERIAL

- B31 - AISI 316L Stainless steel
- T1 - Brass
- D1 - PVC
- D2 - PP
- D8 - PVDF
- E1 - PTFE
- L61 - Hastelloy C 22
- Special materials are quoted on request

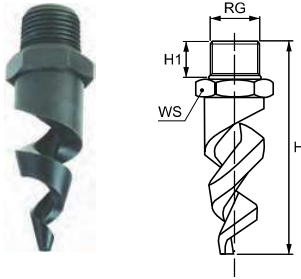

## SPIRAL NOZZLES / WIDE FREE PASSAGE

The E-X series nozzles, with their typical elongated spiral design, work on the impact principle, by deflection of a water stream onto their spiral profile that provides the desired spray angle. Their specific shape with no internal parts leaves a larger internal free passage suitable to work with higher capacities and for higher clog resistance than other nozzles of the same size.

The capacity values on darker background can be obtained with metal nozzles only as plastic nozzles cannot ensure resistance in harsh operating conditions. If the capacity values you are looking for are those on darker background, we recommend to choose metal nozzles for their longer operating life.

■ Thread specification: BSPT, NPT

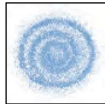

Spray section

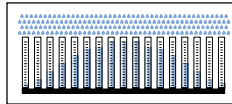

Convex distribution



### Typical applications

- Gas cooling
- Exhaust scrubbers
- Desulfurization
- Cooling

### Other applications

- Spray of chemicals
- Fire prevention
- Fire suppression

Code	RG inch	D mm	D1 mm	Capacity at different pressure values (l/min) (bar)								Dimension mm			
				0.7	1.0	2.0	3.0	5.0	7.0	10	H	H1	WS		
120°	3/8"	4.8	4.8	11.4	13.6	19.2	23.5	30.3	35.9	42.9	70	15	22		
				5.6	5.6	15.3	18.3	25.9	31.7	40.9				48.4	57.9
		6.4	6.4	20.0	24.0	33.9	41.5	53.6	63.4	75.8					
	1/2"	9.5	9.5	45.6	54.5	77.1	94.4	122	144	172	86	18	27		
				11.1	11.1	61.8	73.9	105	128	165				196	234
	3/4"	12.7	12.7	79.7	95.3	135	165	213	252	301	130	20	27		
				19.0	19.0	180	215	304	372	480				568	679
	1"	16.0	16.0	126	150	212	260	336	397	475	131	26	34		
				19.0	19.0	180	215	304	372	480				568	679
	1 1/2"	22.2	22.2	245	293	414	507	655	774	926	171	27	50		
				25.4	25.4	320	383	541	663	856				1013	1210
				28.6	28.6	361	431	610	747	964				1141	1364
2"	35.0	35.0	527	629	890	1090	1407	1665	1990	279	32	65			
			38.1	38.1	672	803	1136	1391	1796				2125	2540	
3"	44.5	44.5	985	1178	1666	2040	2634	3116	3725	267	32	90			
			51.0	51.0	1280	1530	2164	2650	3421				4048	4838	
4"	63.5	63.5	1990	2379	3364	4120	5319	6293	7522	293	36	115			

### ES / SILICON CARBIDE NOZZLES

PNR designs and supplies spiral nozzles made out of several types of silicon carbide for applications where fluids containing abrasive solid particles must be sprayed and long nozzle service life is required. Please contact our Sales department for more detailed information.



ES / SILICON CARBIDE NOZZLES

### HOW TO MAKE UP THE NOZZLE CODE

Spiral nozzles with extra wide internal passage are widely used in pollution treatment and can be supplied with customized connections. Please refer to the picture of Silicon carbide nozzles on the left. Locknut fitting makes assembly easier and more convenient. This design, the only one possible for Silicon carbide nozzles, is optional for nozzles cast in alloys or stainless steel. To identify such nozzles, please note the following product coding.

#### EHW 3747 xx Xy

xx = Material code, see MATERIAL table on the below page

y = CONNECTION CODE B - BSPT, Male thread  
N - NPT, Male thread  
F - Locknut fitting

### HOW TO MAKE UP THE NOZZLE CODE

EX.: ECW 2230 B31XB

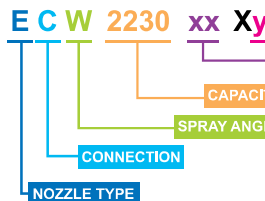

- B31 - AISI 316L Stainless steel

- T1 - Brass

- D1 - PVC

- D2 - PP

- D8 - PVDF

- E1 - PTFE

- L61 - Hastelloy C 22

- Special materials are quoted on request