

STEAM CONSUMPTION CHART

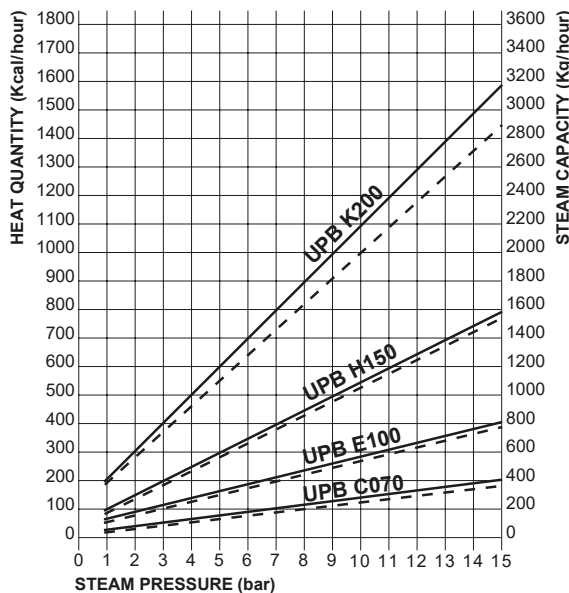

Heat quantity ———
Steam pressure - - - - -

The table above shows the working condition of UPB C070 B31 eductor when set at 50 cm depth.

MIXING EDUCTORS

UPB mixing eductors are energy saving products. Their robust bell-shaped body minimizes the risk of damage during maintenance operations and the Venturi design assures a high mixing efficiency. These eductors enable the circulation of large volumes of liquid and are ideal for continuous blending and stirring of liquids or solutions in tanks. The UPB eductors are installed at the bottom of a tank and pressurized to spray the solution. This flow creates a powerful negative pressure that allows to take in four times the liquid volume, mix it with a solution inside the nozzle and spray it back into the tank at a high speed. 1 HP pump and UPB mixing eductor can replace a 5 HP mixing educator. UPB eductors are an efficient way to get the best performance from re-circulating process tanks and are cost-effective because they reduce the electrical costs.

- **Typical applications** Liquid mixing in electroplating and automotive paint factories
- **Thread specification** BSPT, BSPP, NPT
- **Max working temperature** LT 80°C (PP), 90°C (PVDF)
- **Materials**
 - B31** AISI 316L Stainless steel
 - D6** PP, chemically bonded fiberglass
 - D82** PVDF, moulded (3/8" Parallel Male thread)

Code	RG inch	D mm	Flow rate at pressure (l/min) (bar)					D1 mm	L mm	L1 mm	WS mm
			1.0	2.0	3.0	4.0	5.0				
UPB C070 B31Sx	3/8"	7.0	34	48	59	68	76	45	98	15	22
UPB C070 D6Sx		7.0	34	48	59	68	76				
UPB C070 D82Sx		7.0	34	48	59	68	76				
UPB E100 B31Rx	1/2"	10.0	63	89	109	126	141	60	132	20	30
UPB E100 B31Sx	3/4"	10.0	63	89	109	126	141	60	132	20	30
UPB E100 D6Sx											
UPB H150 B31Sx	1 1/2"	15.0	155	220	268	310	346	110	225	30	60
UPB K200 B31Sx	2"	20.0	206	287	357	410	460	102	295	30	70

EX.: UPB C070 B31Sx — x = Thread codes

- B** = BSPT, S.Steel only
- G** = BSPP, PP & PVDF
- N** = NPT, all materials

We are at your disposal to realize UPB eductors on demand: PNR will give you the code and the dimensions

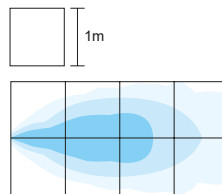

Under normal operating conditions, with feed pressure values ranging from 2 to 4 bars, eductors with a total capacity equal to 20% of the liquid volume to be stirred proved to be adequate for most industrial applications. Please contact us for additional information about eductors layouts.

UPD (MIXING EDUCTORS)

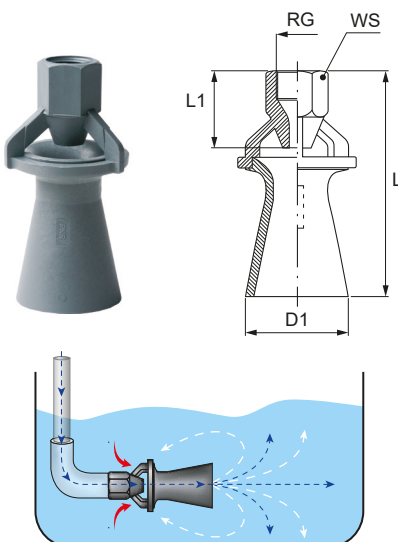

MIXING EDUCTORS

UPD mixing eductors, whose design applies the "Coanda Effect", enable the circulation of large volumes of liquid. They are installed at the bottom of a tank and pressurized to spray the solution.

This flow creates a powerful negative pressure that allows to take in four times the liquid volume, mix it with a solution inside the nozzle and spray it back into the tank at a high speed. 1 HP pump and UPB mixing eductor can replace a 5 HP mixing educator. UPD eductors offer a high mixing efficiency and are cost effective because they save energy and are resistant to wear and corrosion. UPD eductors have the same technical features of the UPB models, but they come with a female thread connection.

- **Thread specification** BSP, NPT
- **Materials**
 - B31** AISI 316L Stainless steel
 - D6** PP, chemically bonded fiberglass
- **Max working temperature** LT 80°C (PP)
- **Typical applications** Liquids mixing in electroplating, automotive painting, chemical plants.

Code	RG inch	D mm	Flow rate at pressure (l/min) (bar)					D1 mm	L mm	L1 mm	WS mm
			1.0	2.0	3.0	4.0	5.0				
UPD E100 D6xx	3/4"	10	63	89	109	126	141	75	147	30	34
UPD H150 D6Sxx	1 1/2"	15	141	199	243	281	313	80	225	45	60
UPD H150 B31Sxx	1 1/2"	15	141	199	243	281	313	80	239	83	60
UPD K200 B31Sxx	2"	20	206	287	357	412	460	102	295	83	70

EX.: UPD E100 D6xx — xx = Thread codes

- SG** - BSP
- SN** - NPT